

365nm UV LED Gen 2 Emitter

# LZ1-00UV00

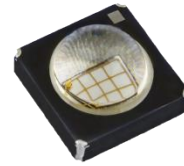

## Key Features

- 365nm UV LED with 1200mW flux output at 2.7W power dissipation
- Ultra-small foot print – 4.4mm x 4.4mm
- Highest Radiant Flux density
- Surface mount ceramic package with integrated glass lens
- Very low Thermal Resistance (4.2°C/W)
- JEDEC Level 1 for Moisture Sensitivity Level
- Lead (Pb) free and RoHS compliant
- Reflow solderable (up to 6 cycles)
- Emitter available on Standard or Miniature MCPCB (optional)

## Typical Applications

- Curing
- Printing
- PCB Exposure
- Sterilization
- Medical
- Currency Verification
- Fluorescence Microscopy
- Inspection of dyes, rodent and animal contamination
- Forensics

## Description

The LZ1-00UV00 UV LED emitter provides superior radiometric power in the wavelength range specifically required for applications like curing, printing, sterilization, currency verification, and various medical applications. With a 4.4mm x 4.4mm ultra-small footprint, this package provides exceptional optical power density. The patented design has unparalleled thermal and optical performance. The high quality materials used in the package are chosen to optimize light output, have excellent UV resistance, and minimize stresses which results in monumental reliability and radiant flux maintenance.

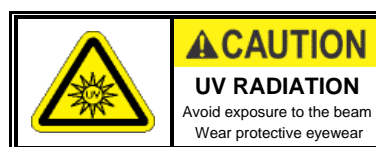

## Part number options

### Base part number

Part number	Description
LZ1-00UV00-xxxx	LZ1 emitter
LZ1-10UV00-xxxx	LZ1 emitter on Standard Star MCPCB
LZ1-30UV00-xxxx	LZ1 emitter on Miniature round MCPCB

### Bin kit option codes

UV, Ultra-Violet (365nm)			
Kit number suffix	Min flux Bin	Color Bin Range	Description
0100*	M	U0 – U0	Flux bin M and above; wavelength U0 bin only

\* Previous version was -0000, please refer to Mechanical Dimensions section on p.6, PCN 54-2 and 55 for more details.

## Radiant Flux Bins

Table 1:

Bin Code	Minimum Radiant Flux ( $\Phi$ ) @ $I_F = 700\text{mA}$ <sup>[1,2]</sup> (mW)	Maximum Radiant Flux ( $\Phi$ ) @ $I_F = 700\text{mA}$ <sup>[1,2]</sup> (mW)
M	1000	1250
N	1250	1600

Notes for Table 1:

1. Radiant flux performance is measured at specified current, 10ms pulse width,  $T_c = 25^\circ\text{C}$ . LED Engin maintains a tolerance of  $\pm 10\%$  on flux measurements.

## Peak Wavelength Bins

Table 2:

Bin Code	Minimum Peak Wavelength ( $\lambda_p$ ) @ $I_F = 700\text{mA}$ <sup>[1]</sup> (nm)	Maximum Peak Wavelength ( $\lambda_p$ ) @ $I_F = 700\text{mA}$ <sup>[1]</sup> (nm)
U0	365	370

Notes for Table 2:

1. Peak wavelength is measured at specified current, 10ms pulse width,  $T_c = 25^\circ\text{C}$ . LED Engin maintains a tolerance of  $\pm 2.0\text{nm}$  on peak wavelength measurements.

## Forward Voltage Bins

Table 3:

Bin Code	Minimum Forward Voltage ( $V_F$ ) @ $I_F = 700\text{mA}$ <sup>[1]</sup> (V)	Maximum Forward Voltage ( $V_F$ ) @ $I_F = 700\text{mA}$ <sup>[1]</sup> (V)
0	3.5	4.5

Notes for Table 3:

1. Forward voltage is measured at specified current, 10ms pulse width,  $T_c = 25^\circ\text{C}$ . LED Engin maintains a tolerance of  $\pm 0.04\text{V}$  for forward voltage measurements.

## Absolute Maximum Ratings

Table 4:

Parameter	Symbol	Value	Unit
DC Forward Current <sup>[1]</sup>	$I_F$	1000	mA
Peak Pulsed Forward Current <sup>[2]</sup>	$I_{FP}$	1000	mA
Reverse Voltage	$V_R$	See Note 3	V
Storage Temperature	$T_{stg}$	-40 ~ +150	°C
Junction Temperature	$T_J$	115	°C
Soldering Temperature <sup>[4]</sup>	$T_{sol}$	260	°C
Allowable Reflow Cycles		6	
ESD Sensitivity <sup>[5]</sup>		> 2,000 V HBM Class 2 JESD22-A114-D	

Notes for Table 4:

- Maximum DC forward current is determined by the overall thermal resistance and ambient temperature. Follow the curves in Figure 11 for current derating.
- Pulse forward current conditions: Pulse Width  $\leq$  10msec and Duty Cycle  $\leq$  10%.
- LEDs are not designed to be reverse biased.
- Solder conditions per JEDEC 020D. See Reflow Soldering Profile Figure 5.
- LED Engin recommends taking reasonable precautions towards possible ESD damages and handling the LZ1-00UV00 in an electrostatic protected area (EPA). An EPA may be adequately protected by ESD controls as outlined in ANSI/ESD S6.1.

## Optical Characteristics @ $T_C = 25^\circ\text{C}$

Table 5:

Parameter	Symbol	Typical	Unit
Radiant Flux (@ $I_F = 700\text{mA}$ )	$\Phi$	1200	mW
Radiant Flux (@ $I_F = 1000\text{mA}$ )	$\Phi$	1680	mW
Peak Wavelength <sup>[1]</sup>	$\lambda_p$	365	nm
Viewing Angle <sup>[2]</sup>	$2\Theta_{1/2}$	70	Degrees
Total Included Angle <sup>[3]</sup>	$\Theta_{0.9V}$	105	Degrees

Notes for Table 5:

- When operating the UV LED, observe safety precaution given in IEC 62471 Risk Group 3. Avoid eye and skin exposure to unshielded product.
- Viewing Angle is the off axis angle from emitter centerline where the radiometric power is  $\frac{1}{2}$  of the peak value.
- Total Included Angle is the total angle that includes 90% of the total radiant flux.

## Electrical Characteristics @ $T_C = 25^\circ\text{C}$

Table 6:

Parameter	Symbol	Typical	Unit
Forward Voltage (@ $I_F = 700\text{mA}$ )	$V_F$	3.8	V
Temperature Coefficient of Forward Voltage	$\Delta V_F / \Delta T_J$	-1.3	mV/°C
Thermal Resistance (Junction to Case)	$R\Theta_{J-C}$	4.2	°C/W

## IPC/JEDEC Moisture Sensitivity Level

Table 7 - IPC/JEDEC J-STD-20D.1 MSL Classification:

Level	Soak Requirements					
	Floor Life		Standard		Accelerated	
	Time	Conditions	Time (hrs)	Conditions	Time (hrs)	Conditions
1	Unlimited	≤ 30°C/ 85% RH	168 +5/-0	85°C/ 85% RH	n/a	n/a

Notes for Table 7:

1. The standard soak time includes a default value of 24 hours for semiconductor manufacturer's exposure time (MET) between bake and bag and includes the maximum time allowed out of the bag at the distributor's facility.

## Mechanical Dimensions (mm)

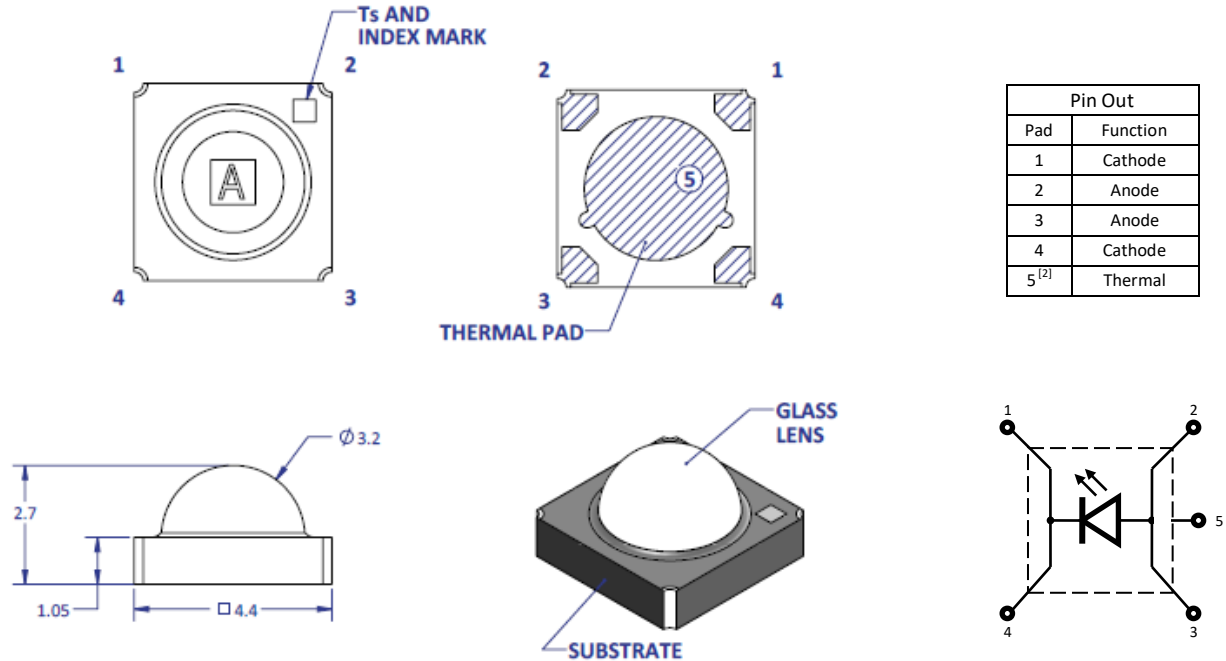

Figure 1: Package outline drawing.

Notes for Figure 1:

1. Unless otherwise noted, the tolerance =  $\pm 0.20$  mm.
2. Thermal contact, Pad 5, is electrically neutral.
3. Previous version of the emitter (p/n: LZ1-00UV00-0000) has different marking: -,+,+,- for pin 1,2,3,4. Please refer to PCN 54-2 for more details.

## Recommended Solder Pad Layout (mm)

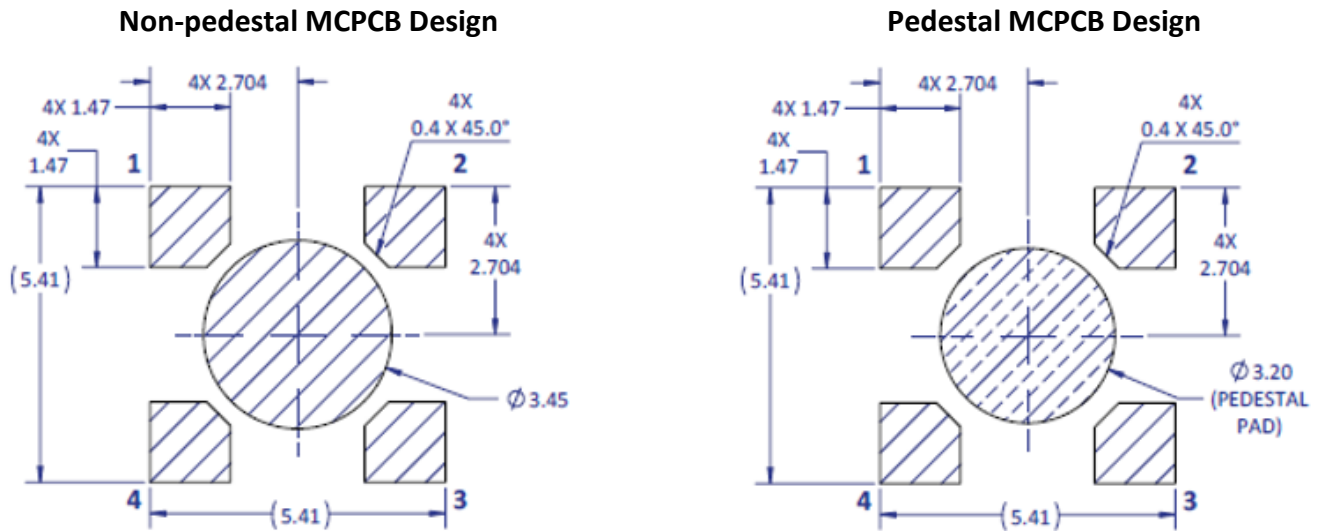

Figure 2a: Recommended solder pad layout for anode, cathode, and thermal pad for non-pedestal and pedestal design

Note for Figure 2a:

1. Unless otherwise noted, the tolerance =  $\pm 0.20$  mm.
2. Pedestal MCPCB allows the emitter thermal slug to be soldered directly to the metal core of the MCPCB. Such MCPCB eliminate the high thermal resistance dielectric layer that standard MCPCB technologies use in between the emitter thermal slug and the metal core of the MCPCB, thus lowering the overall system thermal resistance.
3. LED Engin recommends x-ray sample monitoring for solder voids underneath the emitter thermal slug. The total area covered by solder voids should be less than 20% of the total emitter thermal slug area. Excessive solder voids will increase the emitter to MCPCB thermal resistance and may lead to higher failure rates due to thermal over stress.
4. This emitter is compatible with all LZ1 MCPCBs provided that the MCPCB design follows the recommended solder mask layout (Figure 2b).

## Recommended Solder Mask Layout (mm)

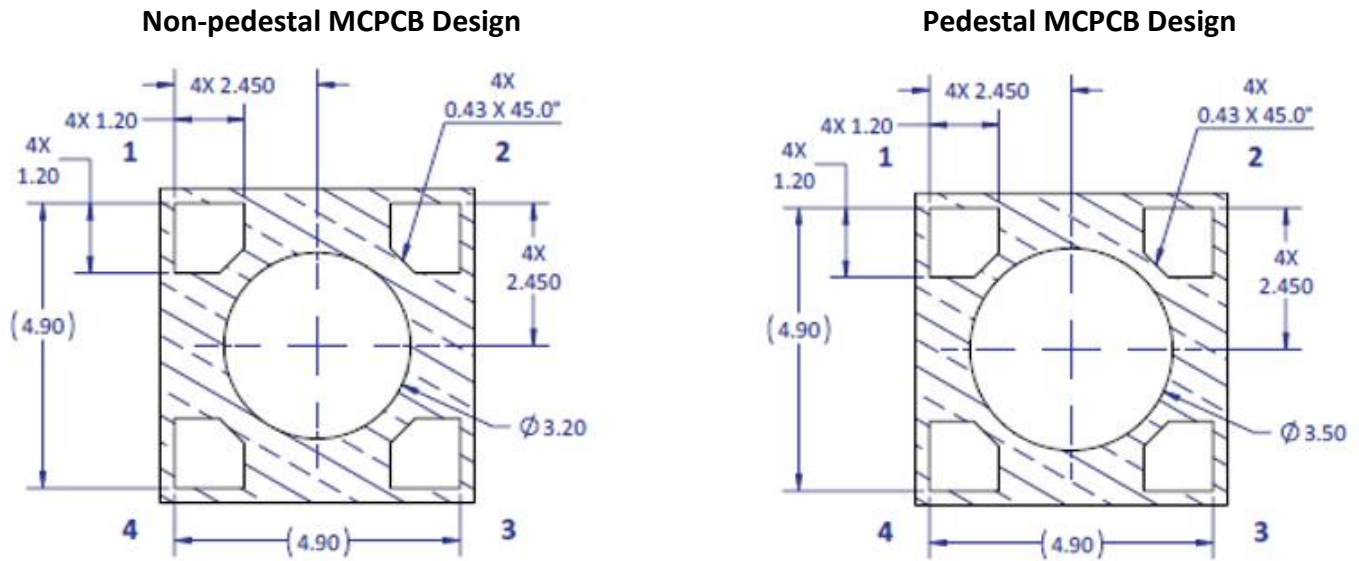

Figure 2b: Recommended solder mask opening for anode, cathode, and thermal pad for non-pedestal and pedestal design

Note for Figure 2b:

1. Unless otherwise noted, the tolerance =  $\pm 0.20$  mm.

## Recommended 8mil Stencil Apertures Layout (mm)

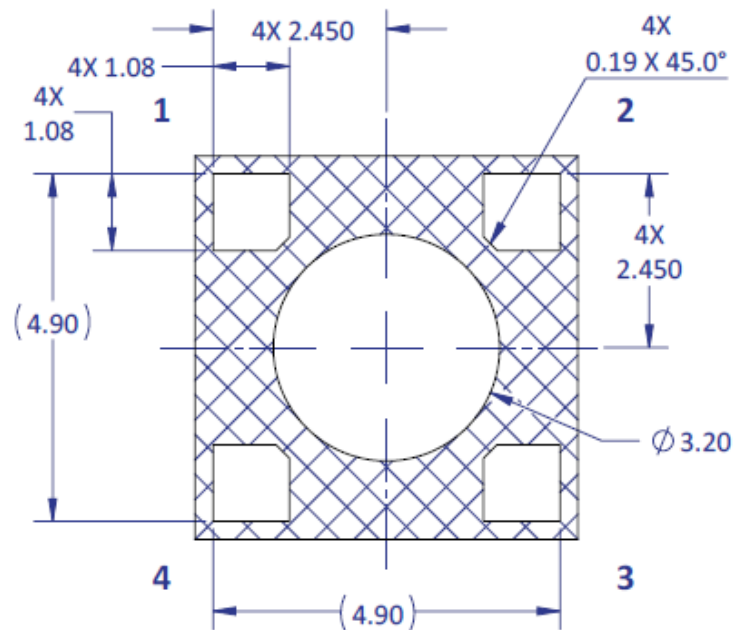

Figure 2c: Recommended solder mask opening for anode, cathode, and thermal pad for non-pedestal and pedestal design

Note for Figure 2c:

1. Unless otherwise noted, the tolerance =  $\pm 0.20$  mm.

## Reflow Soldering Profile



Figure 3: Reflow soldering profile for lead free soldering

## Typical Radiation Pattern

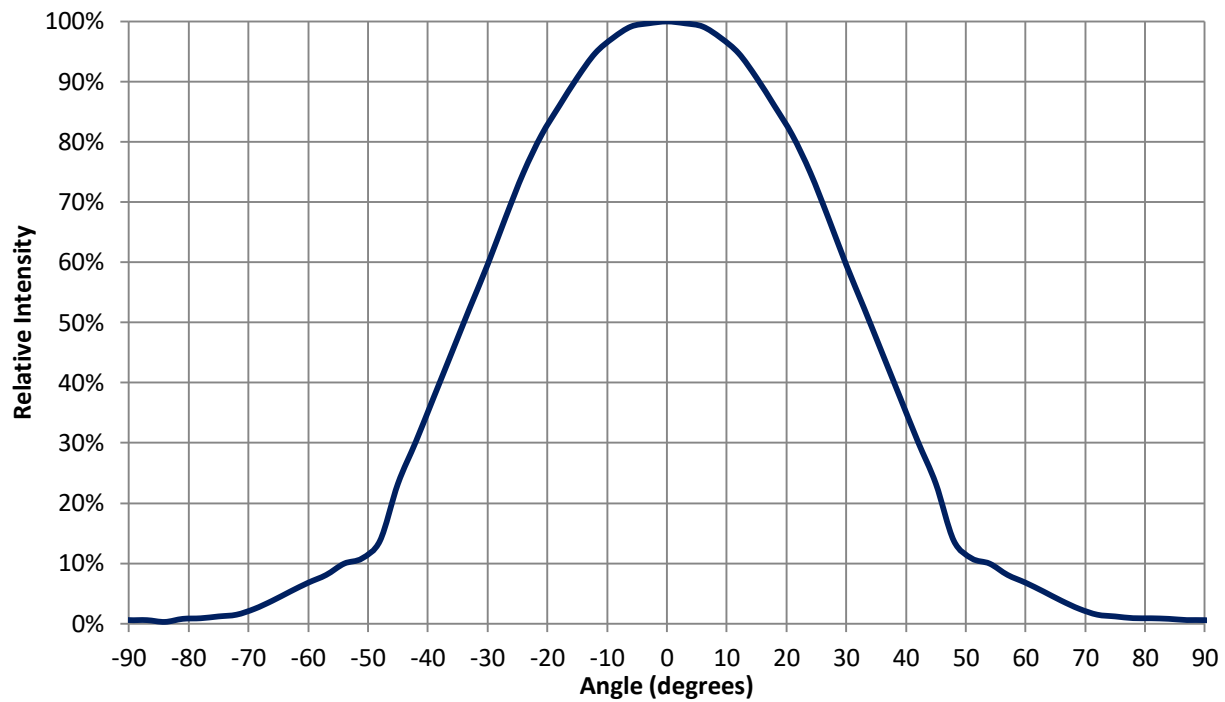

Figure 4: Typical representative spatial radiation pattern



### Typical Relative Spectral Power Distribution

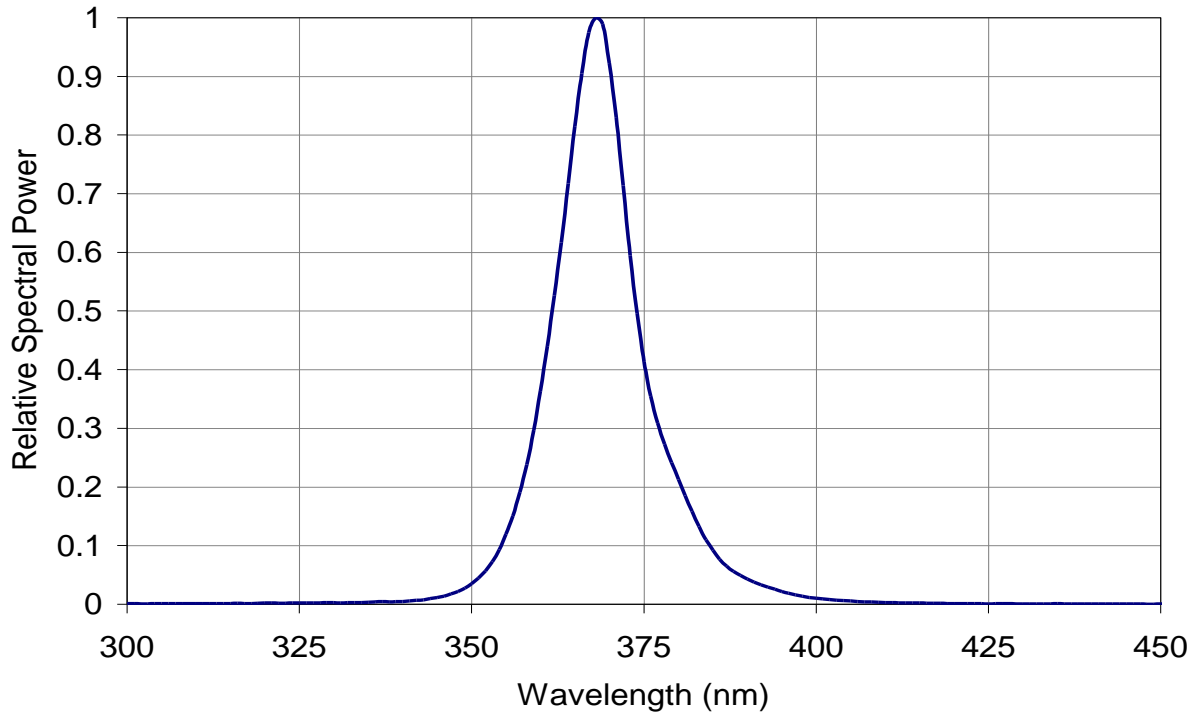

Figure 5: Typical relative spectral power vs. wavelength @ T<sub>c</sub> = 25°C

### Typical Forward Current Characteristics

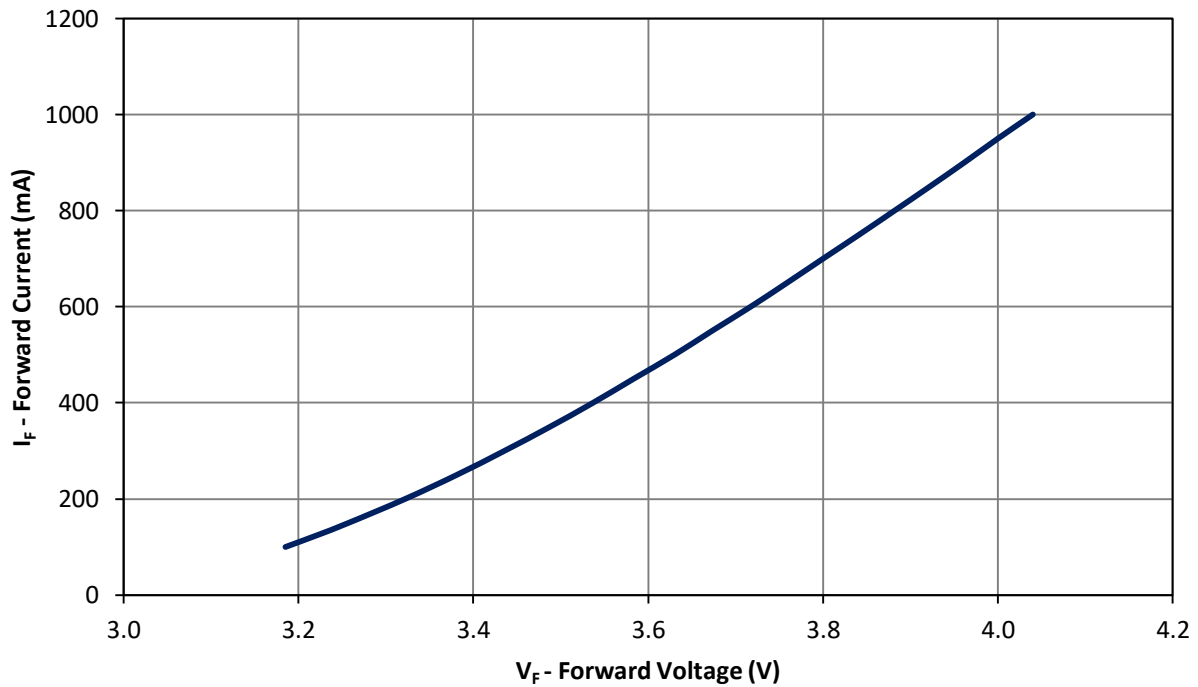

Figure 6: Typical forward current vs. forward voltage @ T<sub>c</sub> = 25°C

### Typical Normalized Radiant Flux over Current

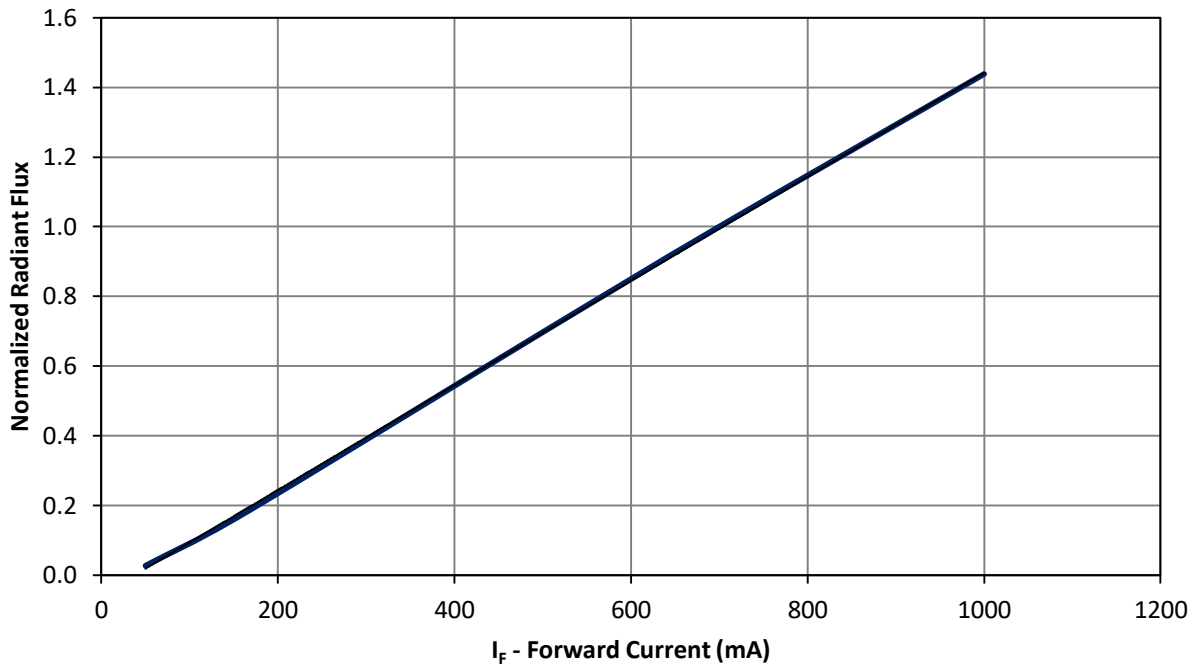

Figure 7: Typical normalized radiant flux vs. forward current @  $T_C = 25^\circ\text{C}$

### Typical Normalized Radiant Flux over Temperature

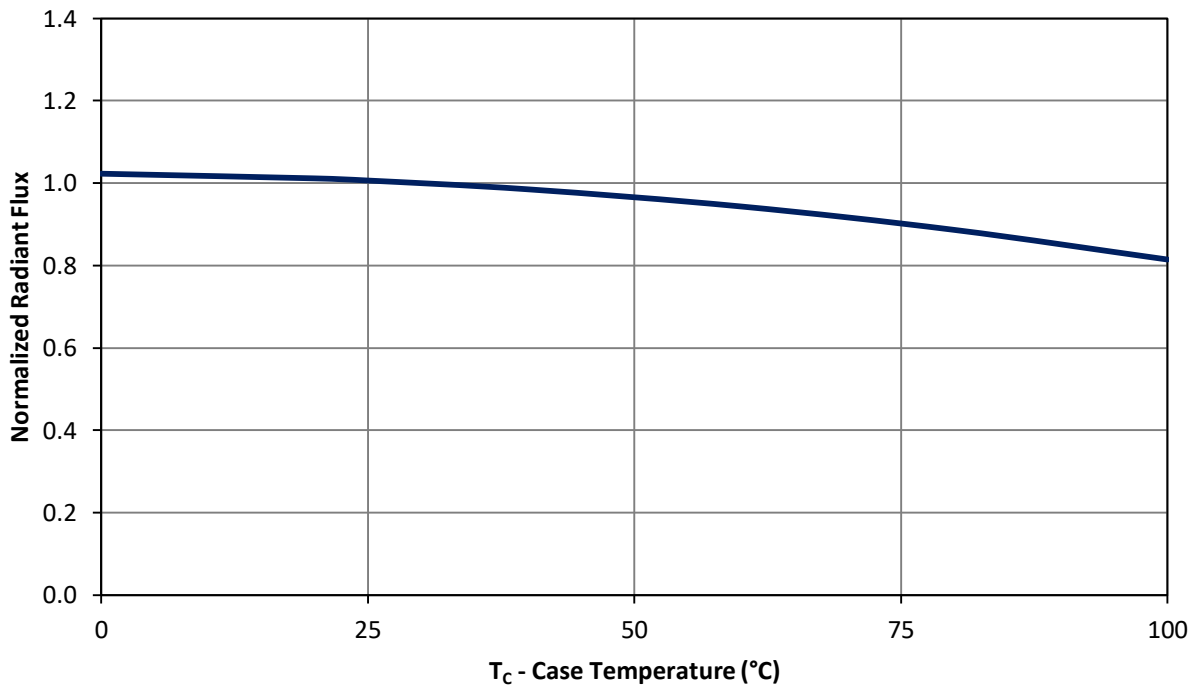

Figure 8: Typical normalized radiant flux vs. case temperature

### Typical Peak Wavelength Shift over Current

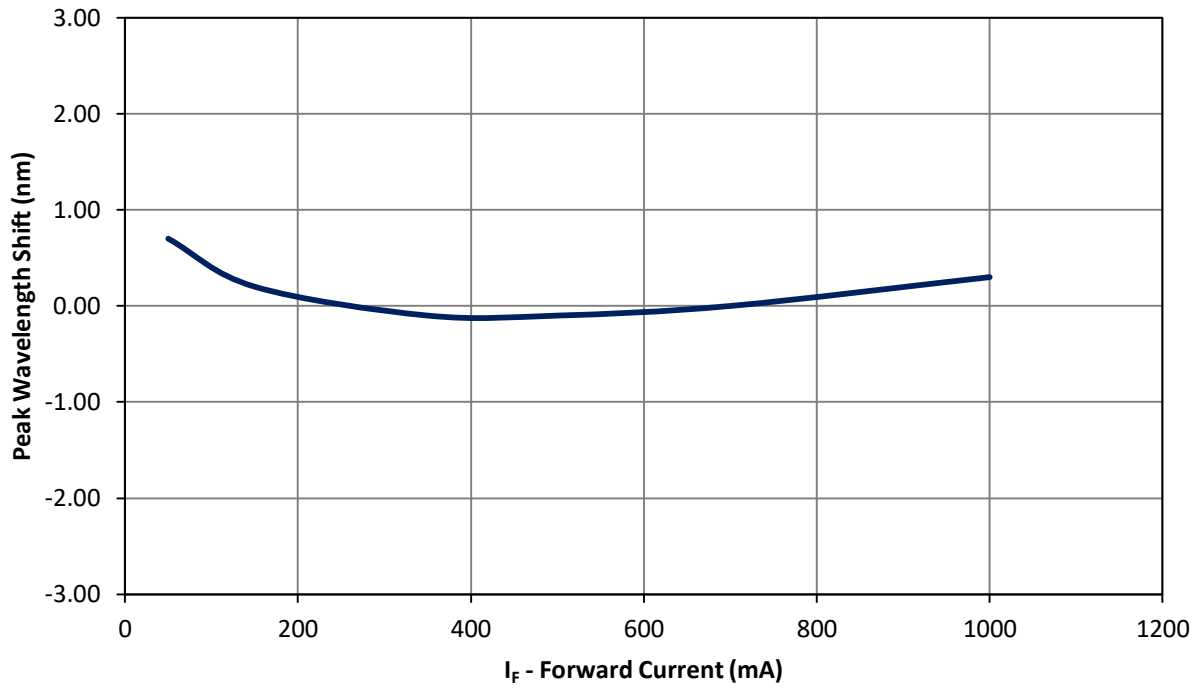

Figure 9: Typical peak wavelength shift vs. forward current @ Tc = 25°C

### Typical Peak Wavelength Shift over Temperature

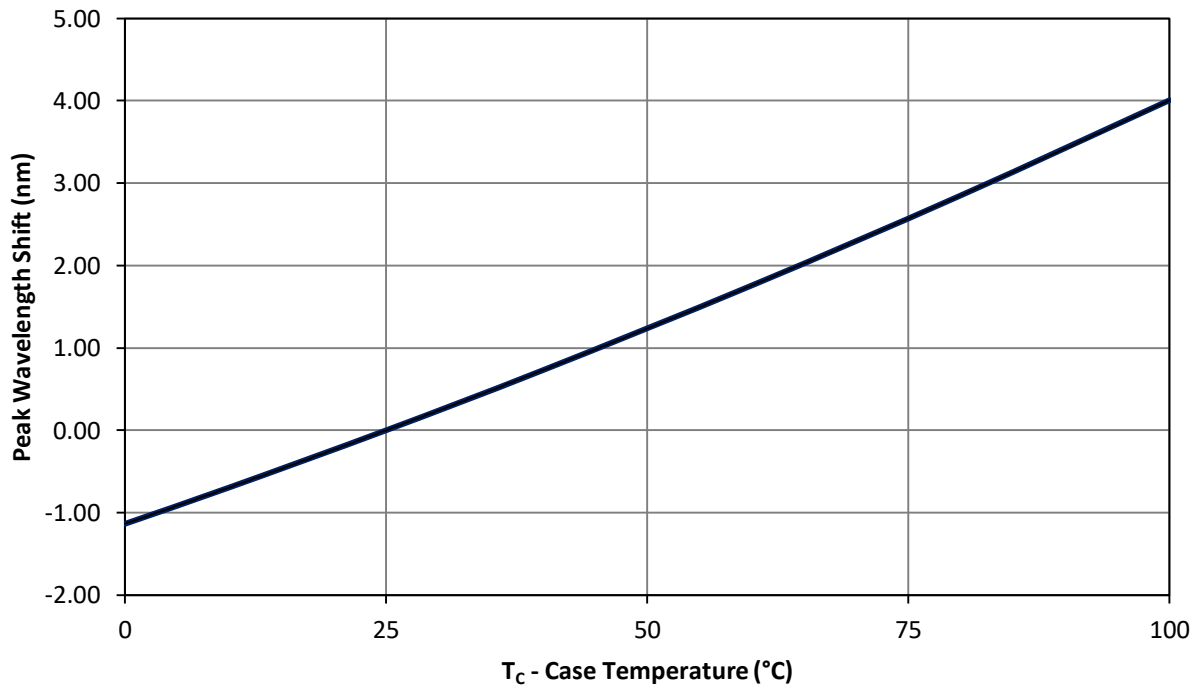

Figure 10: Typical peak wavelength shift vs. case temperature

## Current De-rating

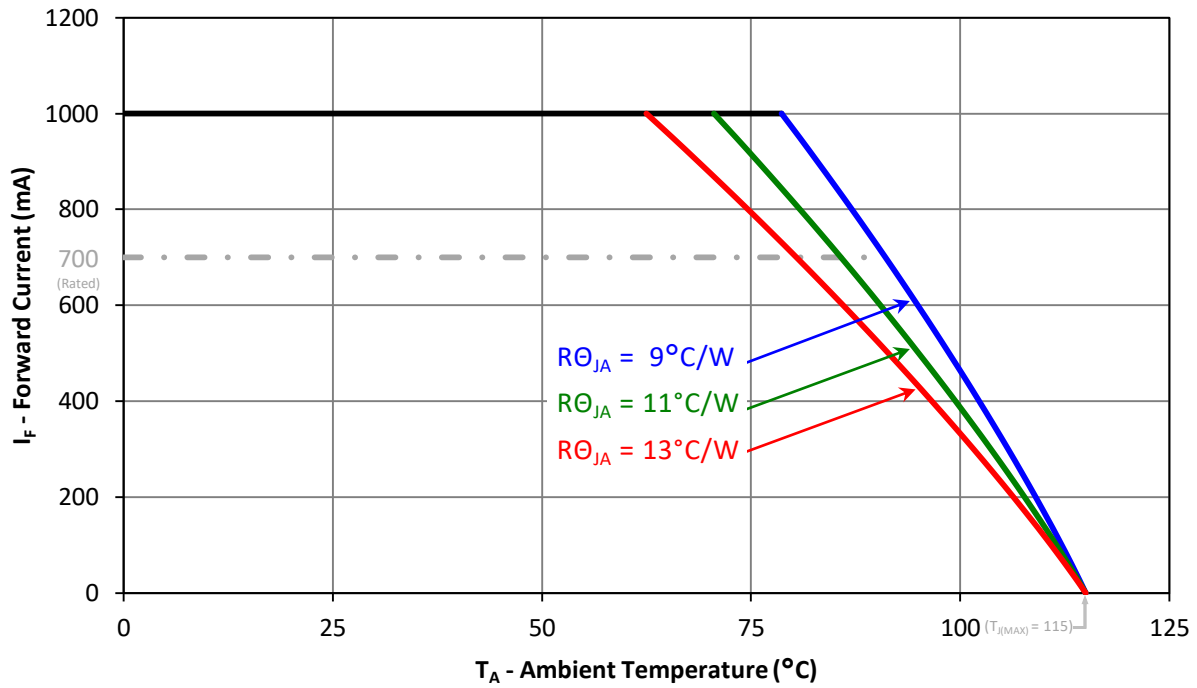

Figure 11: Maximum forward current vs. ambient temperature based on  $T_{J(\text{MAX})} = 115^\circ\text{C}$

Notes for Figure 11:

1.  $RO_{JC}$  [Junction to Case Thermal Resistance] for the LZ1-00UV00 is typically  $4.2^\circ\text{C/W}$ .
2.  $RO_{JA}$  [Junction to Ambient Thermal Resistance] =  $RO_{JC} + RO_{CA}$  [Case to Ambient Thermal Resistance].

## Emitter Tape and Reel Specifications (mm)

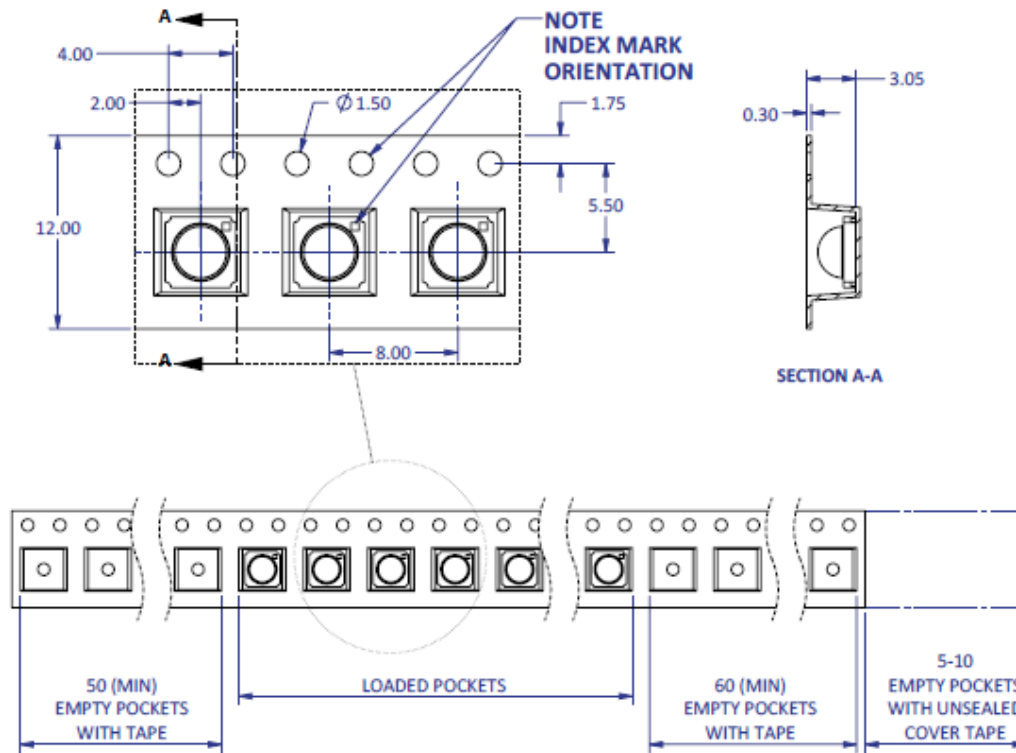

Figure 12: Emitter carrier tape specifications (mm).

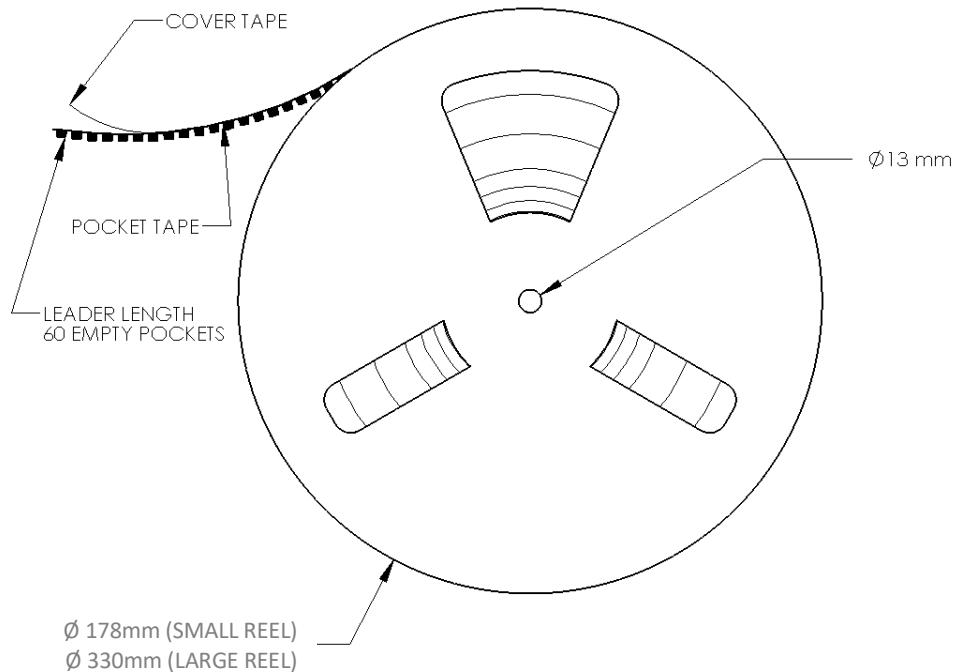

Figure 13: Emitter reel specifications (mm).

**Notes:**

1. Small reel quantity: up to 500 emitters
2. Large reel quantity: 501-2500 emitters.
3. Single flux bin and single wavelength bin per reel.
4. Previous version of the emitter (p/n: LZ1-00UV00-0000) has different emitter position in the Tape and Reel. Please refer to PCN 54-2 for more details.

# LZ1 MCPCB Family

Part number	Type of MCPCB	Diameter (mm)	Emitter + MCPCB Thermal Resistance (°C/W)	Typical $V_f$ (V)	Typical $I_f$ (mA)
LZ1-1xxxxxx	1-channel Star	19.9	4.2 + 1.5 = 5.7	3.8	700
LZ1-3xxxxxx	1-channel Mini	11.5	4.2 + 2.0 = 6.2	3.8	700

## Mechanical Mounting of MCPCB

- MCPCB bending should be avoided as it will cause mechanical stress on the emitter, which could lead to substrate cracking and subsequently LED dies cracking.
- To avoid MCPCB bending:
  - Special attention needs to be paid to the flatness of the heat sink surface and the torque on the screws.
  - Care must be taken when securing the board to the heat sink. This can be done by tightening three M3 screws (or #4-40) in steps and not all the way through at once. Using fewer than three screws will increase the likelihood of board bending.
  - It is recommended to always use plastics washers in combinations with the three screws.
  - If non-taped holes are used with self-tapping screws, it is advised to back out the screws slightly after tightening (with controlled torque) and then re-tighten the screws again.

## Thermal interface material

- To properly transfer heat from LED emitter to heat sink, a thermally conductive material is required when mounting the MCPCB on to the heat sink.
- There are several varieties of such material: thermal paste, thermal pads, phase change materials and thermal epoxies. An example of such material is Electrolube EHTC.
- It is critical to verify the material's thermal resistance to be sufficient for the selected emitter and its operating conditions.

## Wire soldering

- To ease soldering wire to MCPCB process, it is advised to preheat the MCPCB on a hot plate of 125-150°C. Subsequently, apply the solder and additional heat from the solder iron will initiate a good solder reflow. It is recommended to use a solder iron of more than 60W.
- It is advised to use lead-free, no-clean solder. For example: SN-96.5 AG-3.0 CU 0.5 #58/275 from Kester (pn: 24-7068-7601)

# LZ1-1xxxxx

## 1 channel, Standard Star MCPCB (1x1) Dimensions (mm)

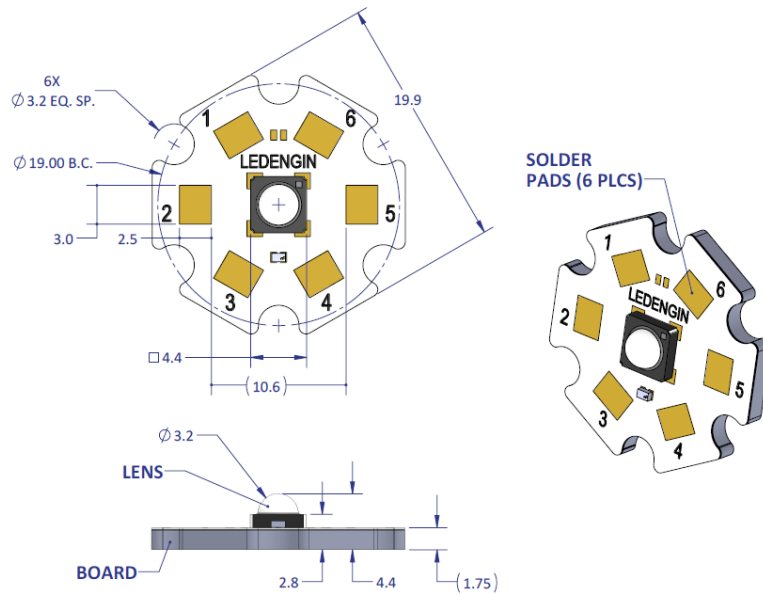

**Notes:**

- Unless otherwise noted, the tolerance =  $\pm 0.2$  mm.
- Slots in MCPCB are for M3 or #4-40 mounting screws.
- LED Engin recommends plastic washers to electrically insulate screws from solder pads and electrical traces.
- LED Engin recommends using thermal interface material when attaching the MCPCB to a heat sink.
- The thermal resistance of the MCPCB is:  $R_{\theta C-B}$  1.5°C/W
- Previous version of the emitter (p/n: LZ1-10UV00-0000) has different marking: -,+,+,- for pin 1,2,3,4. Please refer to PCN 55 for more details.

## Components used

MCPCB: HT04503 (Bergquist)  
 ESD/TVS Diode: BZT52C5V1LP-7 (Diodes, Inc., for 1 LED die)  
 VBUS05L1-DD1 (Vishay Semiconductors, for 1 LED die)

Pad layout			
Ch.	MCPCB Pad	String/die	Function
1	1,2,3	1/A	Cathode -
	4,5,6		Anode +

# LZ1-3xxxxx

## 1 channel, Mini Round MCPCB (1x1) Dimensions (mm)

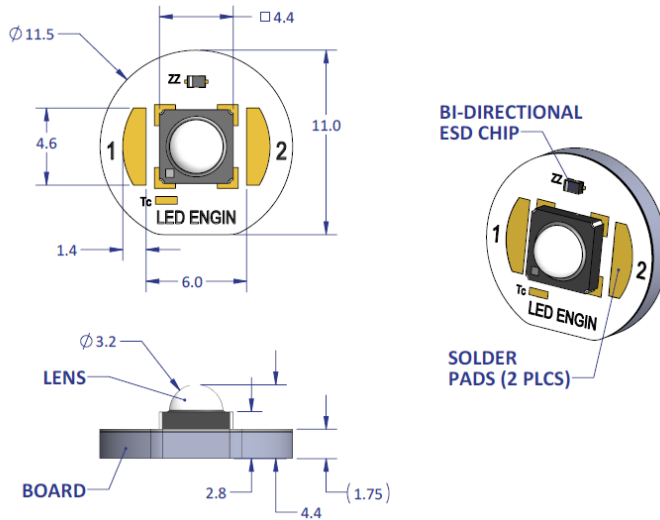

**Notes:**

- Unless otherwise noted, the tolerance =  $\pm 0.20$  mm.
- LED Engin recommends using thermal interface material when attaching the MCPCB to a heat sink.
- The thermal resistance of the MCPCB is:  $R_{\theta C-B} 2.0^{\circ}\text{C/W}$
- Previous version of the emitter (p/n: LZ1-30UV00-0000) has different marking: -,+,+,- for pin 1,2,3,4. Please refer to PCN 55 for more details.

## Components used

MCPCB: HT04503 (Bergquist)  
 ESD/TVS Diode: BZT52C5V1LP-7 (Diodes, Inc., for 1 LED die)  
 VBUS05L1-DD1 (Vishay Semiconductors, for 1 LED die)

Pad layout			
Ch.	MCPCB Pad	String/die	Function
1	1	1/A	Anode +
	2		Cathode -



## About LED Engin

LED Engin, an OSRAM business based in California's Silicon Valley, develops, manufactures, and sells advanced LED emitters, optics and light engines to create uncompromised lighting experiences for a wide range of entertainment, architectural, general lighting and specialty applications. LuxiGen™ multi-die emitter and secondary lens combinations reliably deliver industry-leading flux density, upwards of 5000 quality lumens to a target, in a wide spectrum of colors including whites, tunable whites, multi-color and UV LEDs in a unique patented compact ceramic package. Our LuxiTune™ series of tunable white lighting modules leverage our LuxiGen emitters and lenses to deliver quality, control, freedom and high density tunable white light solutions for a broad range of new recessed and downlighting applications. The small size, yet remarkably powerful beam output and superior in-source color mixing, allows for a previously unobtainable freedom of design wherever high-flux density, directional light is required. LED Engin is committed to providing products that conserve natural resources and reduce greenhouse emissions; and reserves the right to make changes to improve performance without notice.

For more information, please contact [LEDE-Sales@osram.com](mailto:LEDE-Sales@osram.com) or +1 408 922-7200.