

THIS DRAWING IS UNPUBLISHED. RELEASED FOR PUBLICATION
 © COPYRIGHT - By - ALL RIGHTS RESERVED.

LOC		DIST		REVISIONS			
GP	00	P	LTR	DESCRIPTION	DATE	DWN	APVD
		A		INITIAL RELEASE	01/AUG/11	ECC	PB

LV-2

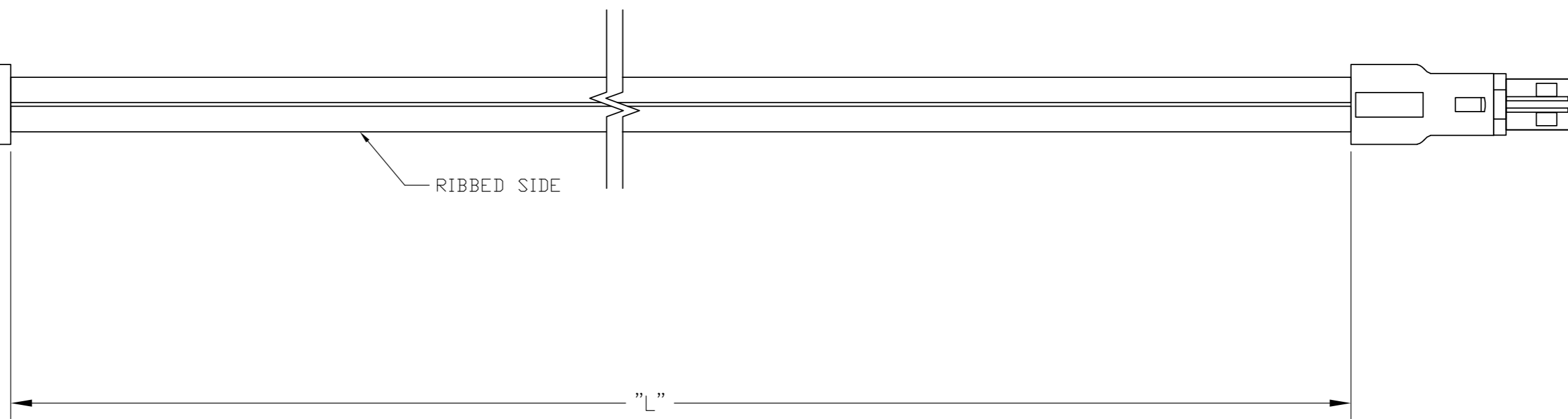
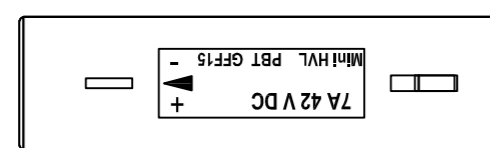
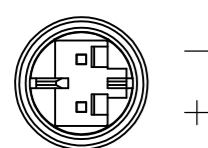

LV-2

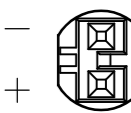

1. PACKAGING ACC. TO TE SPEC.107-18032
BUNDLE EVERY 25 ASSEMBLIES WITH A RUBBER BAND
2. ELECTRICAL TEST CONTAINING "SHORT CIRCUIT TEST, CONTINUITY AND ACCURATE CAVITY ASSIGNMENT TEST" ACC. TO TE-SPEC.108-18857, SUBSECTION 3.1.1

WIRING SCHEDULE AS SHOWN

WIRING SCHEDULE			
OUTLET		SIDE	PLUG
1	+	RIBBED	1
2	-	SMOOTH	2

16.0 FT	±3.84	2181192-8
14.0 FT	±3.36	2181192-7
12.0 FT	±2.88	2181192-6
10.0 FT	±2.4	2181192-5
8.0 FT	±1.92	2181192-4
6.0 FT	±1.44	2181192-3
4.0 FT	±.96	2181192-2
2.0 FT	±.48	2181192-1
"L"	TOLERANCES [INCHES]	TE P/N

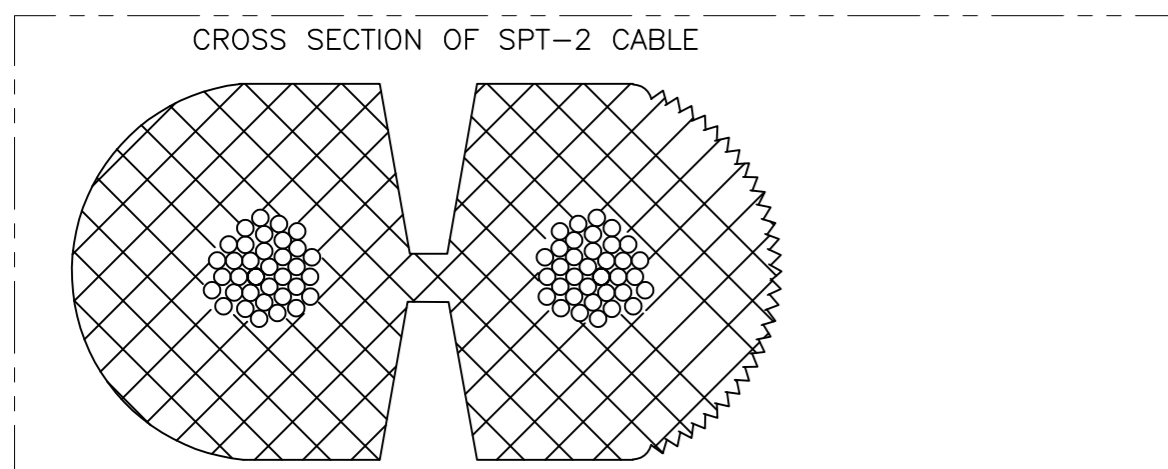

THIS DRAWING IS A CONTROLLED DOCUMENT.		DWN E.C. CLAYBAUGH 16/JUN/11	TE Connectivity	
DIMENSIONS: INCHES		CHK P. BECKER 13/JUL/11	NAME CABLE ASSEMBLY, NECTOR, LV-2, OUTLET TO PLUG	
TOLERANCES UNLESS OTHERWISE SPECIFIED:		APVD P. BECKER 01/AUG/11	DRAWING NO A2 00779 C-2181192	
0 PLC ± - 1 PLC ± - 2 PLC ± - 3 PLC ± - 4 PLC ± - ANGLES ± -		PRODUCT SPEC APPLICATION SPEC	RESTRICTED TO	
MATERIAL	FINISH	WEIGHT	SCALE N.T.S.	SHEET 1 of 1
		CUSTOMER DRAWING	REV	A