

THIS COPY IS PROVIDED ON A RESTRICTED BASIS AND IS NOT TO BE USED IN ANY WAY DETRIMENTAL TO THE INTERESTS OF PANDUIT CORP.

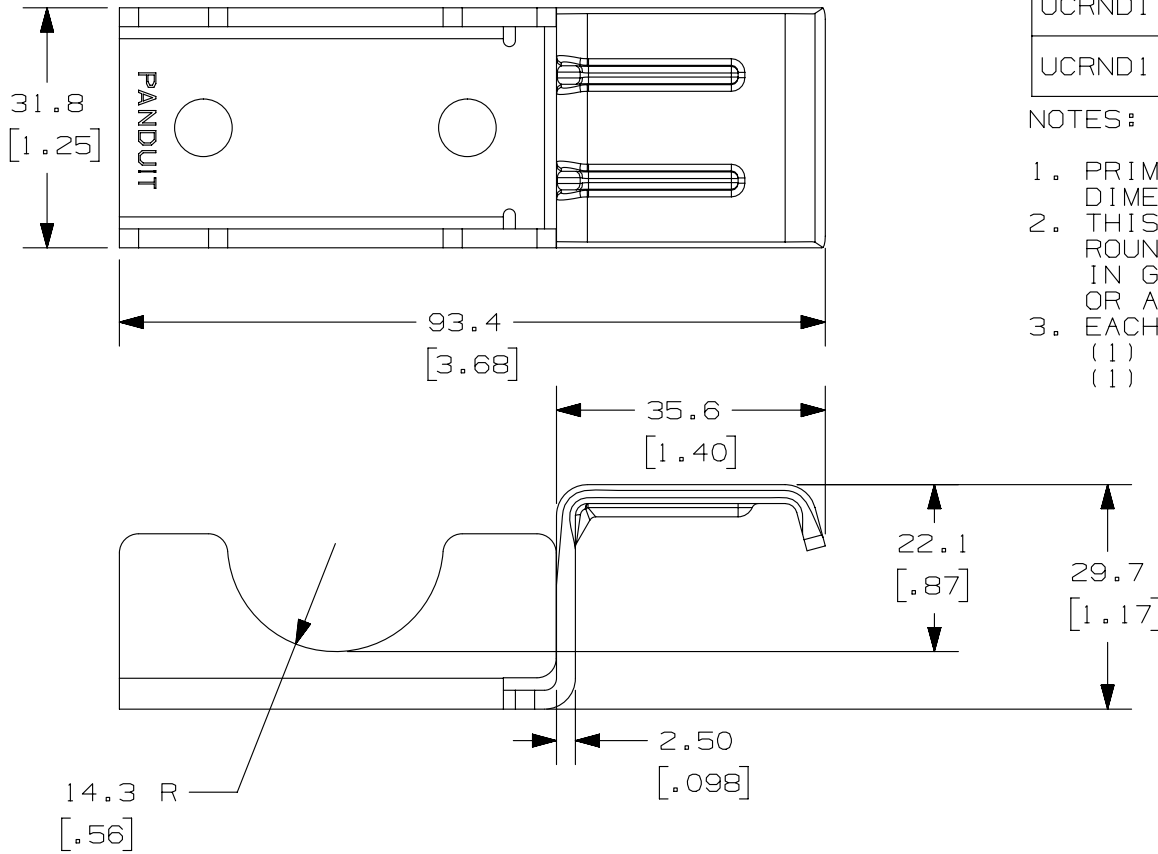

| PANDUIT P/N | MATERIAL                      | WEIGHT / PC           |
|-------------|-------------------------------|-----------------------|
| UCRND1-V316 | 316 STAINLESS STEEL           | 119.9 g<br>(.264 lbs) |
| UCRND1-VC   | COMMERCIAL STEEL / GALVANIZED | 122.2 g<br>(.269 lbs) |

NOTES:

1. PRIMARY DIMENSIONS IN METRIC (mm). DIMENSIONS IN [ ] ARE ENGLISH [in].
2. THIS PRODUCT INTENDED FOR USE WITH ROUND TYPE LADDER RACK (1-INCH DIA.) IN GALVANIZED STEEL, STAINLESS STEEL, OR ALUMINUM CONSTRUCTIONS.
3. EACH ASSEMBLY INCLUDES:  
(1) BRACKET  
(1) U-BOLT ASSEMBLY COMPRISED OF M6 X 1 THREADS AND (2) M6 X 1 HEX NUTS

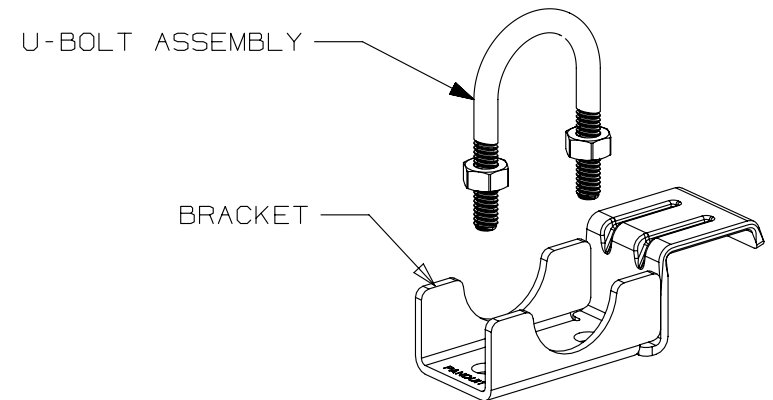

| REV | DATE     | BY   | CHK  | APR  | DESCRIPTION                                     | ECN         |
|-----|----------|------|------|------|---|-------------|
| -   | -----    | ---- | ---- | ---- | RELEASED TO PRODUCTION                          | -----       |
| 1   | 06-26-14 | RMHI | RMHI | RGRO | B. UPDATED WEIGHTS IN TABLE<br>A. REVISED TITLE | 12L025AV-DC |
| R   | 04-30-14 | JBN  | RMHI |      | DRAWING RELEASED                                |             |

|   |                         |
|---|-------------------------|
| TITLE<br><b>UNICLIP ROUND RUNG BRACKET</b><br><b>UCRND1</b>                       |                         |
| CUSTOMER DRAWING  |                         |
| ITEM REVISION NAME<br><b>12L025AV/03</b>  | <b>PANDUIT</b>          |
| DATASET FILE NAME<br><b>12L025AV_DC/03B</b>                                       |                         |
| UNLESS OTHERWISE SPECIFIED,<br>DIMENSIONAL TOLERANCES ARE: IN [mm]                |                         |
| .x ± .3 [ .01 ]      .xxx ± .127 [ .005 ]<br>.xx ± .25 [ .010 ]      ANGLES ± 5 ° |                         |
| THIRD ANGLE PROJECTION  |                         |
| DRAWING NUMBER:<br><b>12L025AV-DC</b>   |                         |
| DRAWN BY<br><b>JBN</b>  | DATE<br><b>04-30-14</b> |
| CHK<br><b>RMHI</b>  | SCALE<br><b>N.T.S.</b>  |
| SHT 1 OF 1  |                         |
| SIZE<br><b>A</b>  |                         |