

ELECTRICAL CHARACTERISTICS (T_{case} = 25°C unless otherwise stated)

Parameter	Test Conditions	Min.	Typ.	Max.	Unit
B _V DSS Drain–Source Breakdown Voltage	V _{GS} = 0 I _D = 10mA	40			V
I _D DSS Zero Gate Voltage Drain Current	V _{DS} = 12.5V V _{GS} = 0			1	mA
I _G DSS Gate Leakage Current	V _{GS} = 20V V _{DS} = 0			1	μA
V _{GS(th)} Gate Threshold Voltage*	I _D = 10mA V _{DS} = V _{GS}	1		7	V
g _{fs} Forward Transconductance*	V _{DS} = 10V I _D = 0.2A	0.18			S
G _{PS} Common Source Power Gain	P _O = 2.5W	10			dB
η Drain Efficiency	V _{DS} = 12.5V I _{DQ} = 0.1A	40			%
VSWR Load Mismatch Tolerance	f = 1GHz	20:1			—
C _{iss} Input Capacitance	V _{DS} = 0 V _{GS} = -5V f = 1MHz			12	pF
C _{oss} Output Capacitance	V _{DS} = 12.5V V _{GS} = 0 f = 1MHz			10	pF
C _{rss} Reverse Transfer Capacitance	V _{DS} = 12.5V V _{GS} = 0 f = 1MHz			1	pF

* Pulse Test: Pulse Duration = 300 μs , Duty Cycle ≤ 2%

HAZARDOUS MATERIAL WARNING

The ceramic portion of the device between leads and metal flange is beryllium oxide. Beryllium oxide dust is highly toxic and care must be taken during handling and mounting to avoid damage to this area.

THESE DEVICES MUST NEVER BE THROWN AWAY WITH GENERAL INDUSTRIAL OR DOMESTIC WASTE.

THERMAL DATA

R _{THj-case}	Thermal Resistance Junction – Case	Max. 10°C / W
-----------------------	------------------------------------	---------------

Semelab Plc reserves the right to change test conditions, parameter limits and package dimensions without notice. Information furnished by Semelab is believed to be both accurate and reliable at the time of going to press. However Semelab assumes no responsibility for any errors or omissions discovered in its use. Semelab encourages customers to verify that datasheets are current before placing orders.

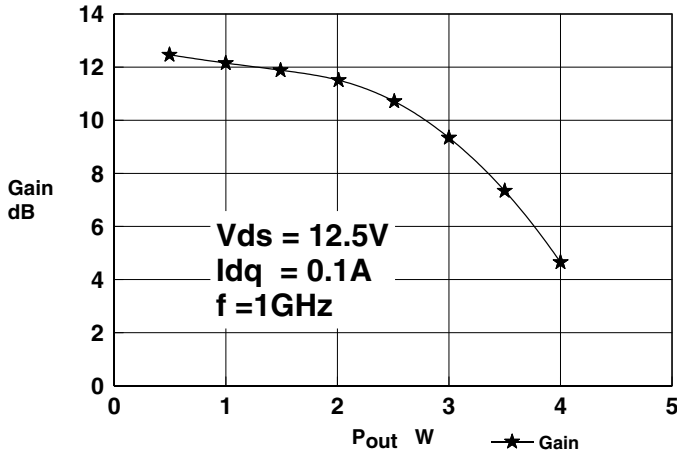

Figure 1- Gain vs. Power Output

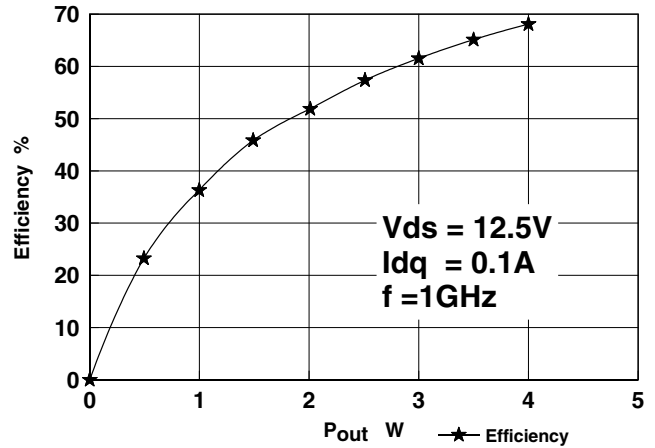

Figure 2 - Efficiency vs Power Output

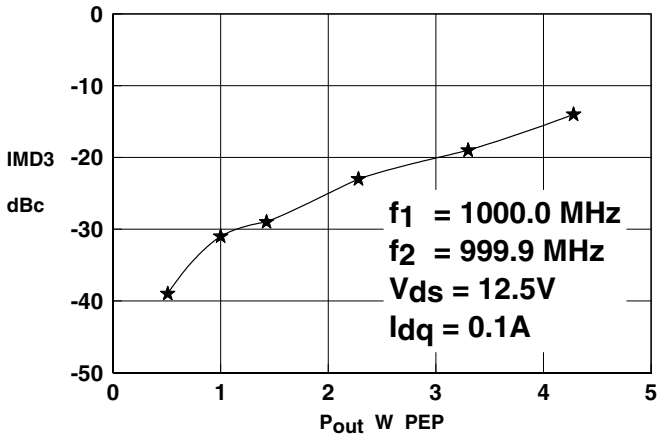

Figure 3 - IMD vs Power Output

OPTIMUM SOURCE AND LOAD IMPEDANCE

Frequency MHz	Z _S Ω	Z _L Ω
1000MHz	2.8 + j3.0	8.0 - j2.0

Typical S Parameters

! V_{DS} = 12.5V, I_{DQ} = 0.2A
 # MHz S M A R 50

Freq MHz	S11		S21		S12		S22	
	mag	ang	mag	ang	mag	ang	mag	ang
50	0.95	-38.2	16.3	160.6	0.015	67.2	0.90	-34.4
100	0.89	-55.9	14.0	139.3	0.026	49.3	0.86	-55.4
150	0.84	-75.2	11.8	122.1	0.032	33.6	0.80	-74.8
200	0.80	-90.6	9.5	107.5	0.034	23.1	0.77	-89.6
250	0.78	-99.5	8.2	97.1	0.035	13.1	0.76	-97.9
300	0.76	-109.8	6.9	92.1	0.035	11.0	0.75	-106.7
350	0.76	-115.0	6.2	80.9	0.035	2.4	0.76	-113.0
400	0.76	-121.6	5.2	74.0	0.031	-2.8	0.76	-119.5
450	0.76	-126.4	4.7	74.9	0.030	0.1	0.77	-123.3
500	0.76	-131.1	4.1	67.7	0.028	-4.6	0.78	-127.5
550	0.77	-135.4	3.8	65.3	0.026	-3.1	0.79	-131.5
600	0.77	-139.6	3.6	60.1	0.024	-4.1	0.79	-135.0
650	0.77	-142.8	3.2	53.9	0.021	-4.9	0.80	-137.9
700	0.74	-148.1	2.6	52.5	0.017	0.4	0.75	-140.6
750	0.76	-148.4	3.0	52.2	0.018	8.5	0.81	-141.2
800	0.77	-153.1	2.8	46.2	0.017	14.5	0.81	-144.1
850	0.77	-155.8	2.6	40.0	0.016	22.0	0.82	-146.2
900	0.77	-159.4	2.4	35.4	0.016	31.0	0.82	-148.5
950	0.77	-163.8	2.3	32.3	0.017	40.7	0.83	-150.7
1000	0.76	-167.7	2.2	29.7	0.017	51.3	0.82	-153.1
1050	0.76	-170.9	2.2	24.6	0.020	58.8	0.83	-155.6

Semelab Plc reserves the right to change test conditions, parameter limits and package dimensions without notice. Information furnished by Semelab is believed to be both accurate and reliable at the time of going to press. However Semelab assumes no responsibility for any errors or omissions discovered in its use. Semelab encourages customers to verify that datasheets are current before placing orders.

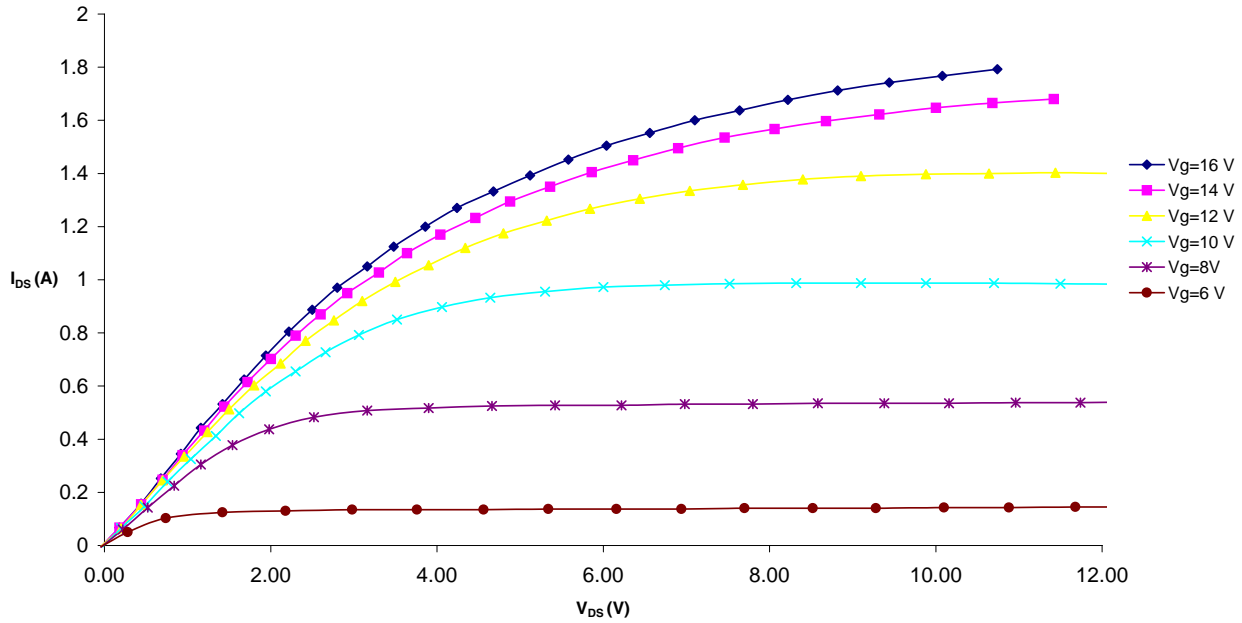

Figure 4 – Typical IV Characteristics.

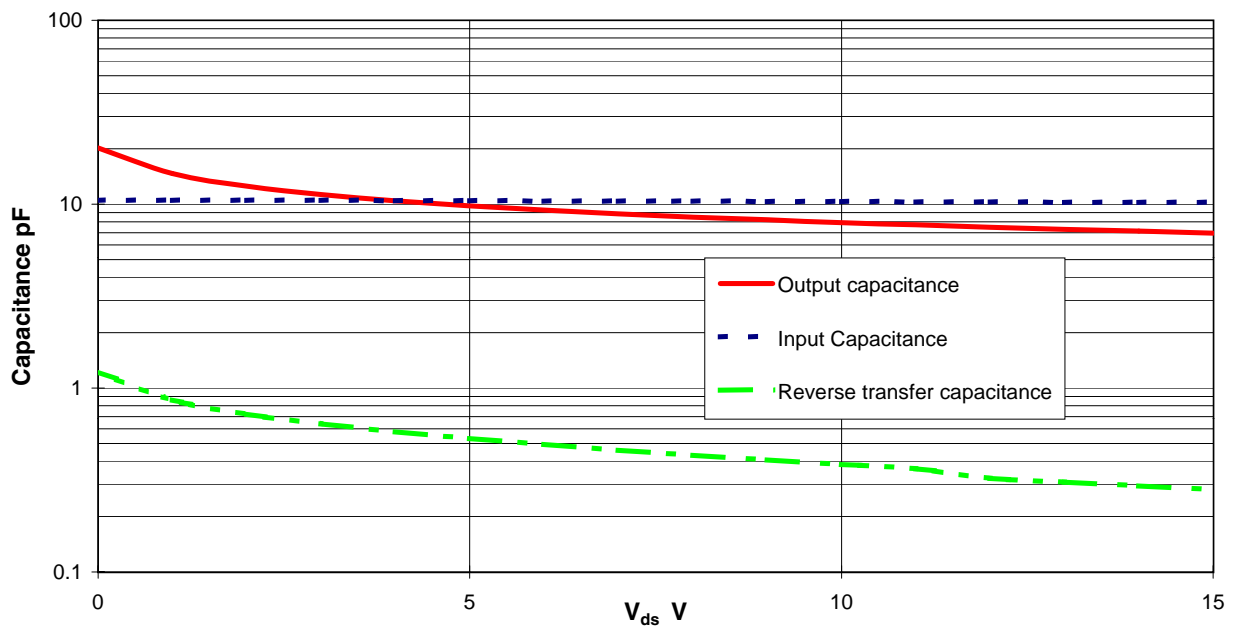
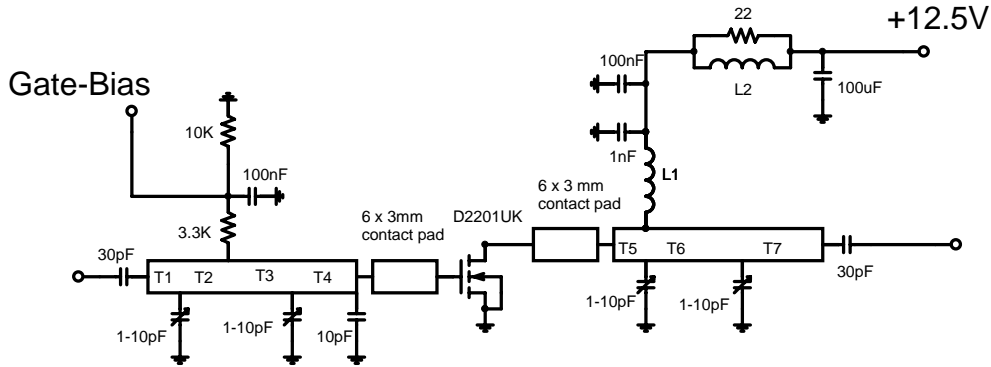

Figure 5 – Typical CV Characteristics.

Semelab Plc reserves the right to change test conditions, parameter limits and package dimensions without notice. Information furnished by Semelab is believed to be both accurate and reliable at the time of going to press. However Semelab assumes no responsibility for any errors or omissions discovered in its use. Semelab encourages customers to verify that datasheets are current before placing orders.



Substrate 0.8mm PTFE/glass, $\epsilon_r=2.5$
 All microstrip lines $W=2.2\text{mm}$

T1 3mm

T2 28mm

T3 12mm

T4 9mm

T5 5mm

T6 23 mm

T7 17mm

L1 7.5 turns 24swg enamelled copper wire, 3mm i.d.

L2 1.5 turns 24swg enamelled copper wire on ferrite core

D2201UK 1000MHz Test Fixture

Mouser Electronics

Authorized Distributor

Click to View Pricing, Inventory, Delivery & Lifecycle Information:

[TT Electronics:](#)

[D2201UK](#)