

| REV | DESCRIPTION\PER REQUEST | DRAWN | DATE |
|-----|-------------------------|-------|------|
| | | | |
| | | | |

CRIMP SIZES REQUIRED
CONTACT: .069[1.75mm]
FERRULE: .324[8.23mm]

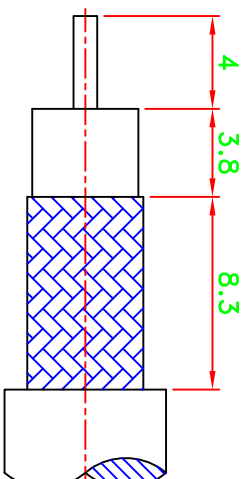

RECOMMENDED
CABLE STRIPPING DIM'S

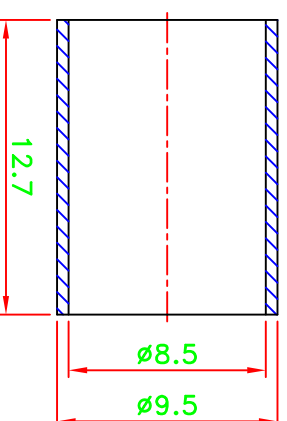
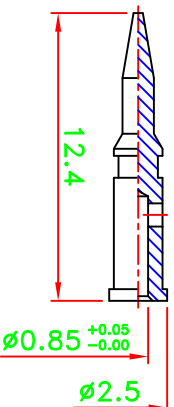
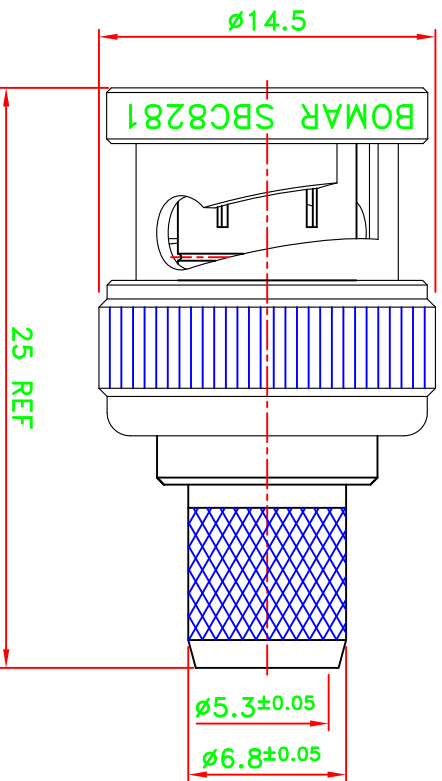

| NO | DESCRIPTION/DRAWING NO. | Q'TY | MATERIAL | FINISH |
|----|-------------------------|------|----------|---------|
| 9 | FERRULE | 1 | BRASS | NICKEL |
| 8 | SHELL | 1 | BRASS | NICKEL |
| 7 | GASKET | 1 | RUBBER | RED |
| 6 | RETAINING RING | 1 | SK5 | NICKEL |
| 5 | SPRING | 1 | SK5 | NICKEL |
| 4 | WASHER | 1 | BRASS | NICKEL |
| 3 | INSULATOR | 1 | PTFE | NATURAL |
| 2 | PIN | 1 | BRASS | GOLD |
| 1 | BODY | 1 | BRASS | NICKEL |

BC-10026B

| | | |
|----------|---------------|-----------------------------------|
| PART NO. | SBC8281 | * MAJOR DIMENSION |
| APPROVED | DATE 04/17/14 | UNLESS OTHERWISE NOTED TOLERANCES |
| CHECKED | DATE 04/17/14 | 0.5-6 = ± 0.2 |
| DRAWN | DATE 04/17/14 | 6-30 = ± 0.4 |
| | | 30-120 = ± 0.6 |
| | | 120-315 = ± 1.0 |
| | | ANGLES = $\pm 5^\circ$ |
| SCALE | 3/1 | UNIT |
| | | mm |

| | |
|-----------------------------------|--------------------------------------|
| Bommar Interconnect Products, Inc | |
| TITLE | BNC CRIMP PLUG |
| DRAWING NO. | ASBNC-13373-G2-75-TGN |
| FILE NO. | W:\P2\AS\ASBNC\ASBNC-13373-G2-75-TGN |
| REV | B |