

T H E R M O M E T R I C S  
A C O M M I T M E N T T O E X C E L L E N C E

# DAT

## Discharge Air Temperature Sensor

The Discharge Air Temperature sensor is used to measure the temperature of the air that is emitted from the air ducts. This temperature reading is fed back to the control module, and the system compares this temperature reading to what the occupant of the vehicle has the temperature set at on the air conditioning system. The control module calculates the temperature delta and automatically adjusts the HVAC system to minimize this temperature difference.

### Applications

- Vehicles with automatic air conditioning
- Vehicle in cabin temperature measurement



### Features

- High accuracy and long term stability
- Fast response time
- Small size & flexible
- Integral connector
- “Fir-Tree” or “Twist-Lock” for fast installation & easy service
- The parts passed 2000 hour + submersion test’
- Alternate RvT curves available
- Different geometries to meet package requirements

**Amphenol**  
**Advanced Sensors**

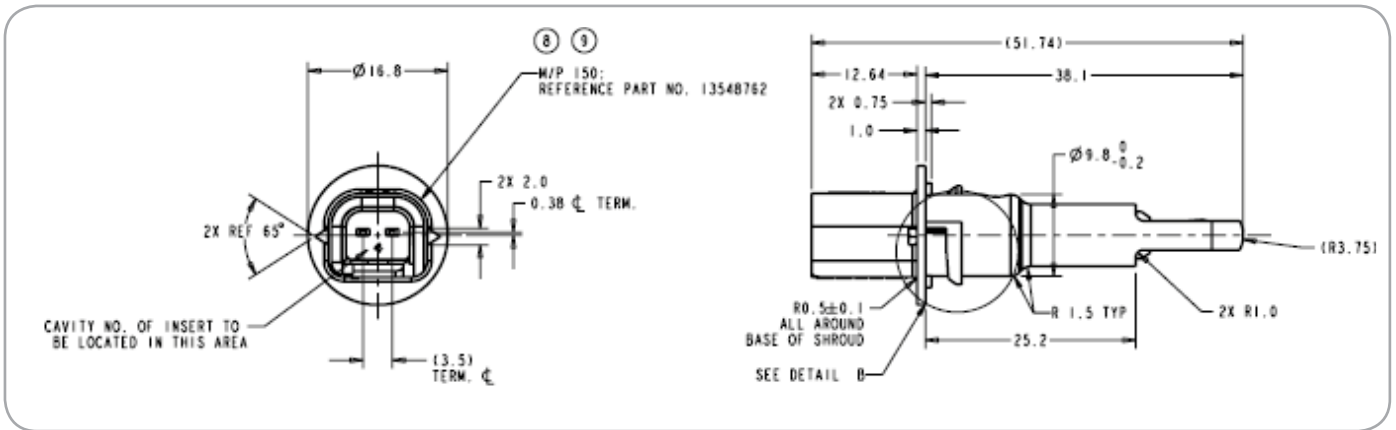

## Specifications

### R @ 25°C

3000 Ω ± 1.0%

### B (25/100)

3988K

### Operating Temperature Range

-40 to 85°C

### Storage Temperature Range

-40 to 90°C

### Temperature Accuracy

+/- 0.20°C @ 25°C

+/- 0.30°C @ 40°C

### Response Time

10 seconds from 60°C oil to 20°C oil

### NTC Part number

NDUS7655

### Housing Material

Nylon 6/6

### Weight

3 gr

### Connector:

Packard Electric 150 series

### Mating Connector

Packard Electric 12047662

## Resistance vs. Temperature Data

Resistance = 3000 Ohms at 25.00 °C Rtol. @ 25°C 1%

Temp. (°C)	Rnominal (ohms)	Res. Tol. ±%	Rmin. (Ohms)	Rmax. (Ohms)	Temp Coef (%/°C)	Temp Coef (±°C)
-40.00	100950.00	2.90	98,008.00	103,892.00	6.70	0.40
-35.00	72777.00	2.70	70,786.00	74,767.00	6.40	0.40
-30.00	53100.00	2.60	51,739.00	54,461.00	6.20	0.40
-25.00	39111.00	2.40	38,173.00	40,049.00	6.00	0.40
-20.00	29121.00	2.20	28,469.00	29,773.00	5.80	0.40
-15.00	21879.00	2.10	21,422.00	22,335.00	5.60	0.40
-10.00	16599.00	1.90	16,277.00	16,921.00	5.40	0.40
-5.00	12695.00	1.80	12,466.00	12,923.00	5.30	0.30
0.00	9795.00	1.70	9,632.00	9,958.00	5.10	0.30
5.00	7616.00	1.50	7,500.00	7,733.00	5.00	0.30
10.00	5970.00	1.40	5,886.00	6,054.00	4.80	0.30
15.00	4712.00	1.30	4,652.00	4,773.00	4.70	0.30
20.00	3747.00	1.20	3,703.00	3,791.00	4.50	0.30
25.00	3000.00	1.00	2,970.00	3,030.00	4.40	0.20
30.00	2417.00	1.20	2,389.00	2,445.00	4.30	0.30
35.00	1959.00	1.30	1,935.00	1,984.00	4.10	0.30
40.00	1598.00	1.40	1,576.00	1,620.00	4.00	0.30
45.00	1311.00	1.50	1,291.00	1,330.00	3.90	0.40
50.00	1081.00	1.60	1,064.00	1,098.00	3.80	0.40
55.00	895.90	1.70	881.00	910.70	3.70	0.40
60.00	746.40	1.80	733.30	759.50	3.60	0.50
65.00	624.90	1.80	613.40	636.40	3.50	0.50
70.00	525.60	1.90	515.50	535.70	3.40	0.60
75.00	444.40	2.00	435.50	453.30	3.20	0.60
80.00	377.40	2.10	369.50	385.30	3.20	0.60
85.00	321.70	2.20	314.70	328.70	3.20	0.70

# Mouser Electronics

Authorized Distributor

Click to View Pricing, Inventory, Delivery & Lifecycle Information:

[Amphenol:](#)

[A-1996](#) [GE-1856](#)