

RF Power Field Effect Transistors

N-Channel Enhancement-Mode Lateral MOSFETs

Designed for CDMA base station applications with frequencies from 1805 MHz to 1995 MHz. Can be used in Class AB and Class C for all typical cellular base station modulation formats.

- Typical Single-Carrier W-CDMA Performance: $V_{DD} = 30$ Volts, $I_{DQ} = 1300$ mA, $P_{out} = 50$ Watts Avg., IQ Magnitude Clipping, Channel Bandwidth = 3.84 MHz, Input Signal PAR = 9.9 dB @ 0.01% Probability on CCDF.

| Frequency | G_{ps} (dB) | η_D (%) | Output PAR (dB) | ACPR (dBc) |
|-----------|---------------|--------------|-----------------|------------|
| 1930 MHz | 17.8 | 29.2 | 7.0 | -34.2 |
| 1960 MHz | 17.8 | 28.2 | 7.0 | -34.4 |
| 1995 MHz | 18.1 | 27.6 | 7.1 | -34.3 |

- Capable of Handling 10:1 VSWR, @ 32 Vdc, 1840 MHz, 268 Watts CW (1) Output Power (3 dB Input Overdrive from Rated P_{out})
- Typical P_{out} @ 1 dB Compression Point \approx 210 Watts CW

1800 MHz

- Typical Single-Carrier W-CDMA Performance: $V_{DD} = 30$ Volts, $I_{DQ} = 1300$ mA, $P_{out} = 50$ Watts Avg., IQ Magnitude Clipping, Channel Bandwidth = 3.84 MHz, Input Signal PAR = 9.9 dB @ 0.01% Probability on CCDF.

| Frequency | G_{ps} (dB) | η_D (%) | Output PAR (dB) | ACPR (dBc) |
|-----------|---------------|--------------|-----------------|------------|
| 1805 MHz | 18.2 | 30.1 | 7.3 | -35.1 |
| 1840 MHz | 18.1 | 29.1 | 7.4 | -35.4 |
| 1880 MHz | 18.2 | 27.8 | 7.4 | -35.9 |

Features

- Designed for Wide Instantaneous Bandwidth Applications
- Designed for Wideband Applications that Require 40 MHz Signal Bandwidth
- 100% PAR Tested for Guaranteed Output Power Capability
- Characterized with Series Equivalent Large-Signal Impedance Parameters and Common Source S-Parameters
- Internally Matched for Ease of Use
- Integrated ESD Protection
- Greater Negative Gate-Source Voltage Range for Improved Class C Operation
- Designed for Digital Predistortion Error Correction Systems
- Optimized for Doherty Applications
- In Tape and Reel. R3 Suffix = 250 Units per 56 mm, 13 inch Reel. For R5 Tape and Reel option, see p. 17.

MRF8S18210WHSR3
MRF8S18210WGHSR3

1805 MHz - 1995 MHz
50 W AVG., 30 V
SINGLE W-CDMA
LATERAL N-CHANNEL
RF POWER MOSFETs

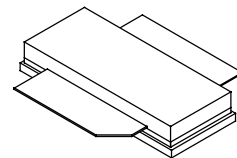

NI-880XS-2
MRF8S18210WHSR3

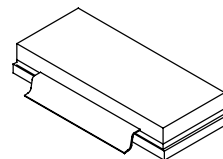

NI-880XS-2 GULL
MRF8S18210WGHSR3

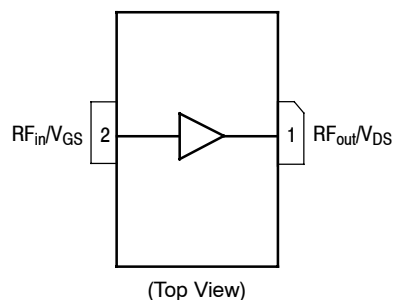

Figure 1. Pin Connections

Table 1. Maximum Ratings

| Rating | Symbol | Value | Unit |
|--------------------------------------|-----------|-------------|----------------|
| Drain-Source Voltage | V_{DSS} | -0.5, +65 | Vdc |
| Gate-Source Voltage | V_{GS} | -6.0, +10 | Vdc |
| Operating Voltage | V_{DD} | 32, +0 | Vdc |
| Storage Temperature Range | T_{stg} | -65 to +150 | $^{\circ}C$ |
| Case Operating Temperature | T_C | 125 | $^{\circ}C$ |
| Operating Junction Temperature (2,3) | T_J | 225 | $^{\circ}C$ |
| CW Operation @ $T_C = 25^{\circ}C$ | CW | 239 | W |
| Derate above $25^{\circ}C$ | | 1.44 | W/ $^{\circ}C$ |

1. Exceeds recommended operating conditions. See CW operation data in Maximum Ratings table.
2. Continuous use at maximum temperature will affect MTTF.
3. MTTF calculator available at <http://www.freescale.com/rf>. Select Software & Tools/Development Tools/Calculators to access MTTF calculators by product.

Table 2. Thermal Characteristics

| Characteristic | Symbol | Value (1,2) | Unit |
|--|------------------|--------------|------|
| Thermal Resistance, Junction to Case Case Temperature 81°C, 50 W CW, 30 Vdc, I _{DQ} = 1300 mA, 1840 MHz Case Temperature 101°C, 210 W CW ⁽³⁾ , 30 Vdc, I _{DQ} = 1300 mA, 1840 MHz | R _{θJC} | 0.48 0.44 | °C/W |

Table 3. ESD Protection Characteristics

| Test Methodology | Class |
|---------------------------------------|-------|
| Human Body Model (per JESD22-A114) | 2 |
| Machine Model (per EIA/JESD22-A115) | B |
| Charge Device Model (per JESD22-C101) | IV |

Table 4. Electrical Characteristics (T_A = 25°C unless otherwise noted)

| Characteristic | Symbol | Min | Typ | Max | Unit |
|----------------|--------|-----|-----|-----|------|
|----------------|--------|-----|-----|-----|------|

Off Characteristics

| | | | | | |
|--|------------------|---|---|----|------|
| Zero Gate Voltage Drain Leakage Current (V _{DS} = 65 Vdc, V _{GS} = 0 Vdc) | I _{DSS} | — | — | 10 | μAdc |
| Zero Gate Voltage Drain Leakage Current (V _{DS} = 30 Vdc, V _{GS} = 0 Vdc) | I _{DSS} | — | — | 5 | μAdc |
| Gate-Source Leakage Current (V _{GS} = 5 Vdc, V _{DS} = 0 Vdc) | I _{GSS} | — | — | 1 | μAdc |

On Characteristics

| | | | | | |
|---|---------------------|-----|------|-----|-----|
| Gate Threshold Voltage (V _{DS} = 10 Vdc, I _D = 306 μAdc) | V _{GS(th)} | 1.2 | 1.9 | 2.7 | Vdc |
| Gate Quiescent Voltage (V _{DD} = 30 Vdc, I _D = 1300 mAdc, Measured in Functional Test) | V _{GS(Q)} | 2.0 | 2.7 | 3.5 | Vdc |
| Drain-Source On-Voltage (V _{GS} = 10 Vdc, I _D = 3.06 Adc) | V _{DS(on)} | 0.1 | 0.24 | 0.3 | Vdc |

Functional Tests ^(4,5) (In Freescale Test Fixture, 50 ohm system) V_{DD} = 30 Vdc, I_{DQ} = 1300 mA, P_{out} = 50 W Avg., f = 1930 MHz, Single-Carrier W-CDMA, IQ Magnitude Clipping, Input Signal PAR = 9.9 dB @ 0.01% Probability on CCDF. ACPR measured in 3.84 MHz Channel Bandwidth @ ±5 MHz Offset.

| | | | | | |
|--|-----------------|------|-------|-------|-----|
| Power Gain | G _{ps} | 17.0 | 17.8 | 20.0 | dB |
| Drain Efficiency | η _D | 26.0 | 29.2 | — | % |
| Output Peak-to-Average Ratio @ 0.01% Probability on CCDF | PAR | 6.7 | 7.0 | — | dB |
| Adjacent Channel Power Ratio | ACPR | — | -34.2 | -30.0 | dBc |
| Input Return Loss | IRL | — | -9 | -7 | dB |

Typical Broadband Performance (In Freescale Test Fixture, 50 ohm system) V_{DD} = 30 Vdc, I_{DQ} = 1300 mA, P_{out} = 50 W Avg., Single-Carrier W-CDMA, IQ Magnitude Clipping, Input Signal PAR = 9.9 dB @ 0.01% Probability on CCDF. ACPR measured in 3.84 MHz Channel Bandwidth @ ±5 MHz Offset.

| Frequency | G _{ps} (dB) | η _D (%) | Output PAR (dB) | ACPR (dBc) | IRL (dB) |
|-----------|----------------------|--------------------|-----------------|------------|----------|
| 1930 MHz | 17.8 | 29.2 | 7.0 | -34.2 | -9 |
| 1960 MHz | 17.8 | 28.2 | 7.0 | -34.4 | -9 |
| 1995 MHz | 18.1 | 27.6 | 7.1 | -34.3 | -13 |

1. MTTF calculator available at <http://www.freescale.com/rf>. Select Software & Tools/Development Tools/Calculators to access MTTF calculators by product.
2. Refer to AN1955, *Thermal Measurement Methodology of RF Power Amplifiers*. Go to <http://www.freescale.com/rf>. Select Documentation/Application Notes - AN1955.
3. Exceeds recommended operating conditions. See CW operation data in Maximum Ratings table.
4. Part internally matched both on input and output.
5. Measurement made with device in straight lead configuration before any lead forming operation is applied.

(continued)

Table 4. Electrical Characteristics ($T_A = 25^\circ\text{C}$ unless otherwise noted) (continued)

| Characteristic | Symbol | Min | Typ | Max | Unit |
|--|----------------------|-----|-------|-----|----------------------|
| Typical Performance (In Freescale Test Fixture, 50 ohm system) $V_{DD} = 30\text{ Vdc}$, $I_{DQ} = 1300\text{ mA}$, 1930 MHz - 1995 MHz Bandwidth | | | | | |
| P_{out} @ 1 dB Compression Point, CW | P1dB | — | 210 | — | W |
| IMD Symmetry @ 80 W PEP, P_{out} where IMD Third Order Intermodulation $\cong 30\text{ dBc}$ (Delta IMD Third Order Intermodulation between Upper and Lower Sidebands > 2 dB) | IMD _{sym} | — | 12 | — | MHz |
| VBW Resonance Point (IMD Third Order Intermodulation Inflection Point) | VBW _{res} | — | 100 | — | MHz |
| Gain Flatness in 65 MHz Bandwidth @ $P_{out} = 50\text{ W Avg.}$ | G _F | — | 0.14 | — | dB |
| Gain Variation over Temperature (-30°C to $+85^\circ\text{C}$) | ΔG | — | 0.02 | — | dB/ $^\circ\text{C}$ |
| Output Power Variation over Temperature (-30°C to $+85^\circ\text{C}$) (1) | $\Delta P1\text{dB}$ | — | 0.008 | — | dB/ $^\circ\text{C}$ |

Typical Broadband Performance — 1800 MHz (In Freescale 1800 MHz Test Fixture, 50 ohm system) $V_{DD} = 30\text{ Vdc}$, $I_{DQ} = 1300\text{ mA}$, $P_{out} = 50\text{ W Avg.}$, Single-Carrier W-CDMA, IQ Magnitude Clipping, Input Signal PAR = 9.9 dB @ 0.01% Probability on CCDF. ACPR measured in 3.84 MHz Channel Bandwidth @ $\pm 5\text{ MHz}$ Offset.

| Frequency | G _{ps} (dB) | η_D (%) | Output PAR (dB) | ACPR (dBc) | IRL (dB) |
|-----------|-------------------------|-----------------|--------------------|---------------|-------------|
| 1805 MHz | 18.2 | 30.1 | 7.3 | -35.1 | -10 |
| 1840 MHz | 18.1 | 29.1 | 7.4 | -35.4 | -9 |
| 1880 MHz | 18.2 | 27.8 | 7.4 | -35.9 | -10 |

1. Exceeds recommended operating conditions. See CW operation data in Maximum Ratings table.

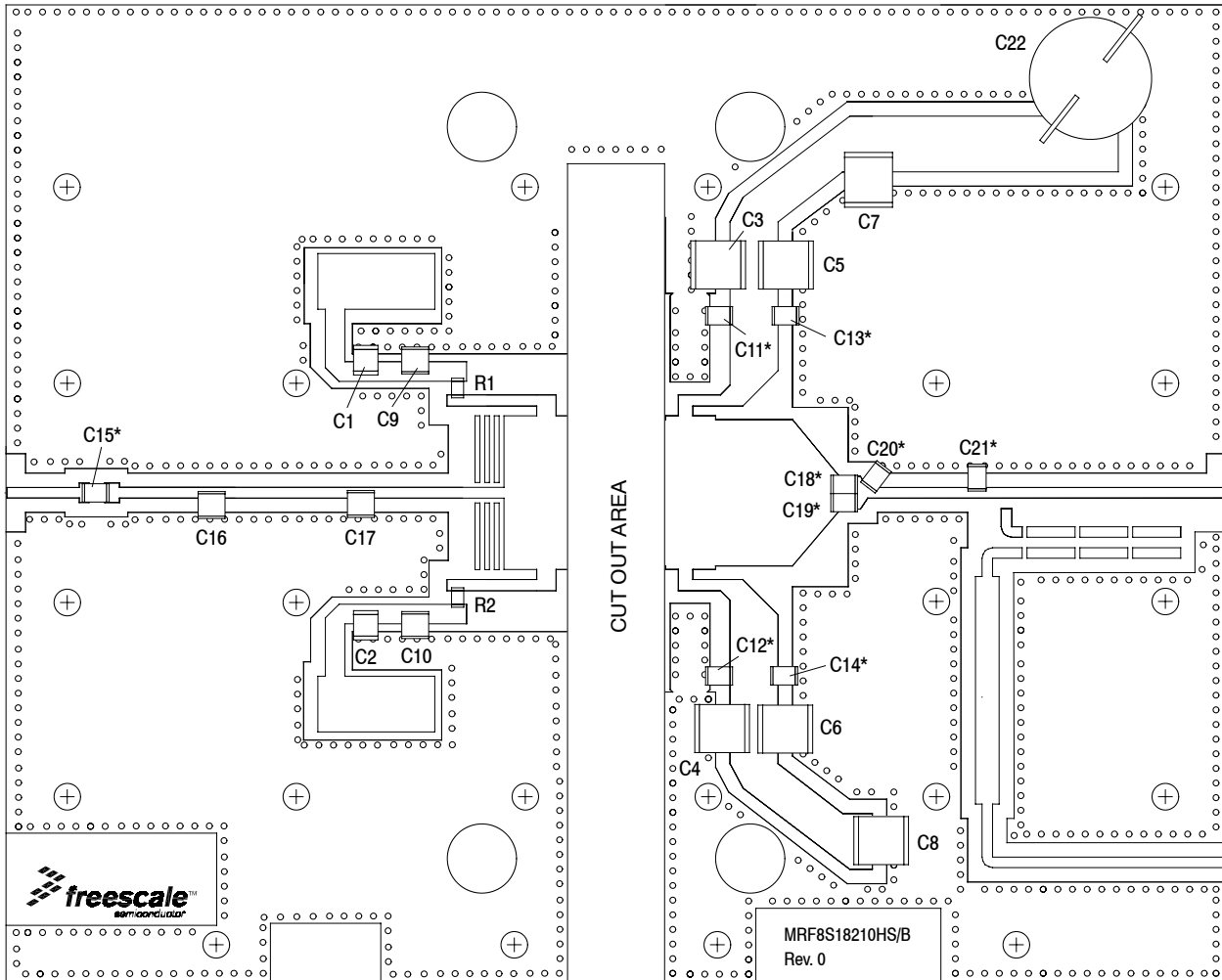

*C11, C12, C13, C14, C15, C18, C19, C20, and C21 are mounted vertically.

Figure 2. MRF8S18210WHSR3(WGHSR3) Test Circuit Component Layout

Table 5. MRF8S18210WHSR3(WGHSR3) Test Circuit Component Designations and Values

| Part | Description | Part Number | Manufacturer |
|-----------------------------|--|-------------------|--------------|
| C1, C2 | 2.2 μ F Chip Capacitors | C3225X7R2A225M | TDK |
| C3, C4, C5, C6, C7, C8 | 10 μ F Chip Capacitors | C5750X7S2A106MT | TDK |
| C9, C10, C11, C12, C13, C14 | 8.2 pF Chip Capacitors | ATC100B8R2BT500XT | ATC |
| C15 | 1.3 pF Chip Capacitor | ATC100B1R3BT500XT | ATC |
| C16, C21 | 1.8 pF Chip Capacitors | ATC100B1R8BT500XT | ATC |
| C17 | 2.0 pF Chip Capacitor | ATC100B2R0BT500XT | ATC |
| C18, C19 | 3.9 pF Chip Capacitors | ATC100B3R9BT500XT | ATC |
| C20 | 1.0 pF Chip Capacitor | ATC100B1R0BT500XT | ATC |
| C22 | 470 μ F, 63 V Electrolytic Capacitor | B41858-C8477-M000 | EPCOS |
| R1, R2 | 10 Ω , 1/4 W Chip Resistors | 232272461009 | Phycomp |
| PCB | 0.020", $\epsilon_r = 3.5$ | RO4350B | Rogers |

TYPICAL CHARACTERISTICS

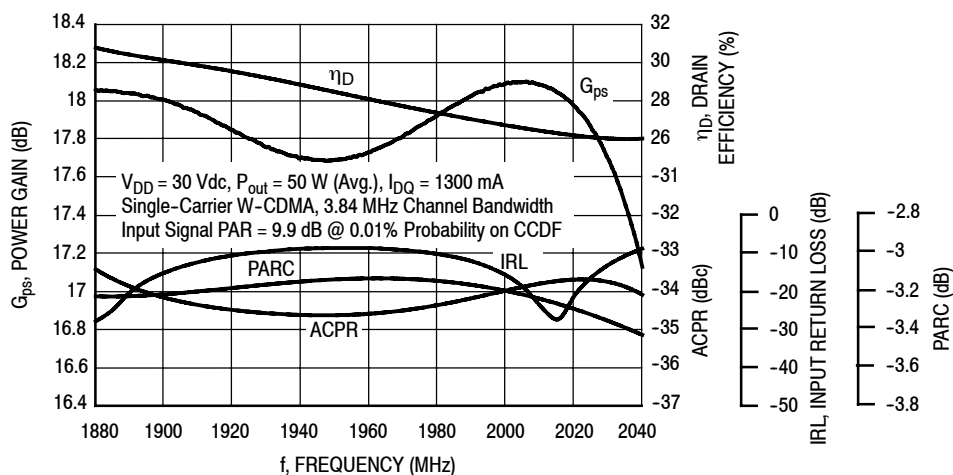

Figure 3. Output Peak-to-Average Ratio Compression (PARC) Broadband Performance @ $P_{out} = 50$ Watts Avg.

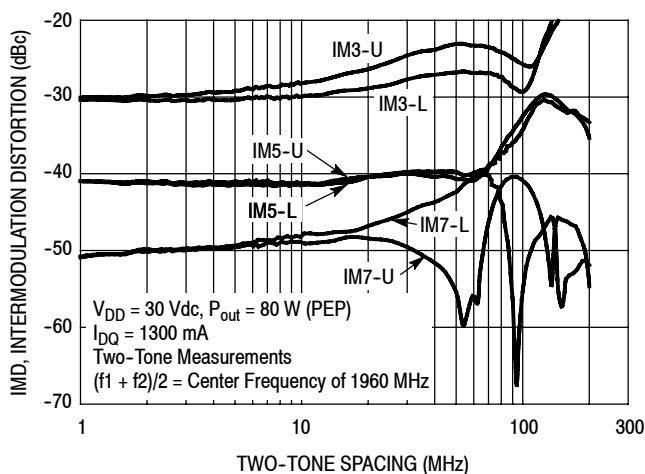

Figure 4. Intermodulation Distortion Products versus Two-Tone Spacing

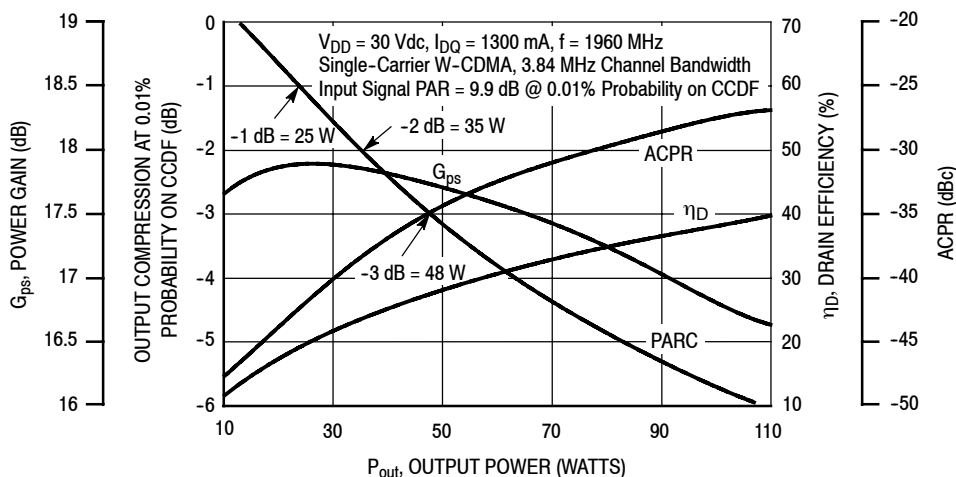

Figure 5. Output Peak-to-Average Ratio Compression (PARC) versus Output Power

TYPICAL CHARACTERISTICS

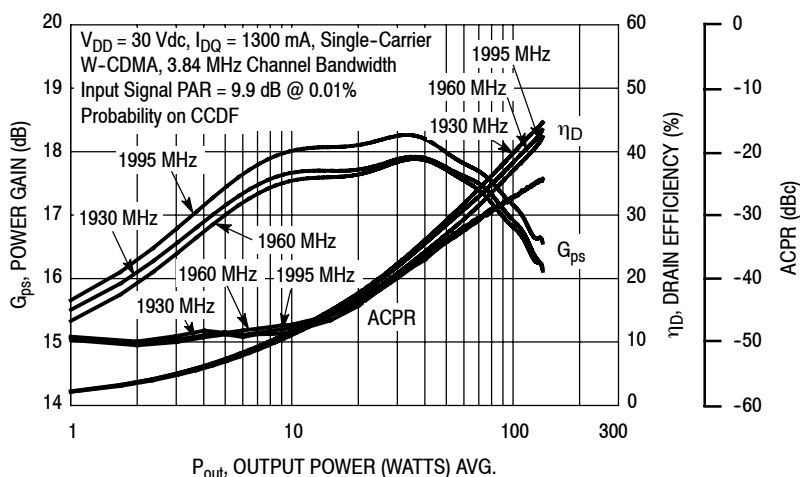

Figure 6. Single-Carrier W-CDMA Power Gain, Drain Efficiency and ACPR versus Output Power

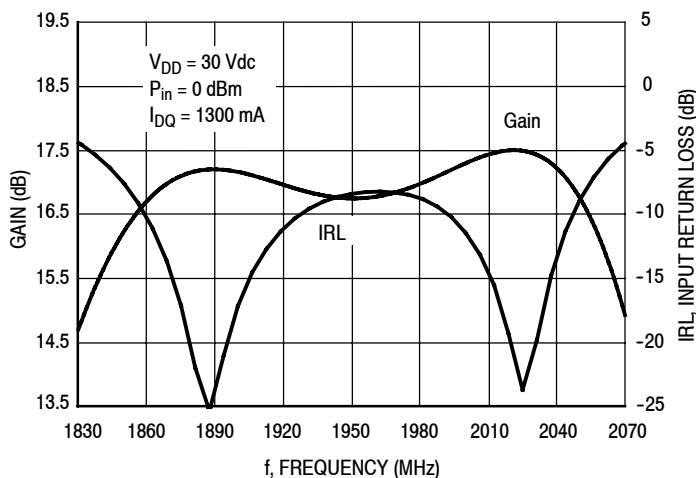

Figure 7. Broadband Frequency Response

W-CDMA TEST SIGNAL

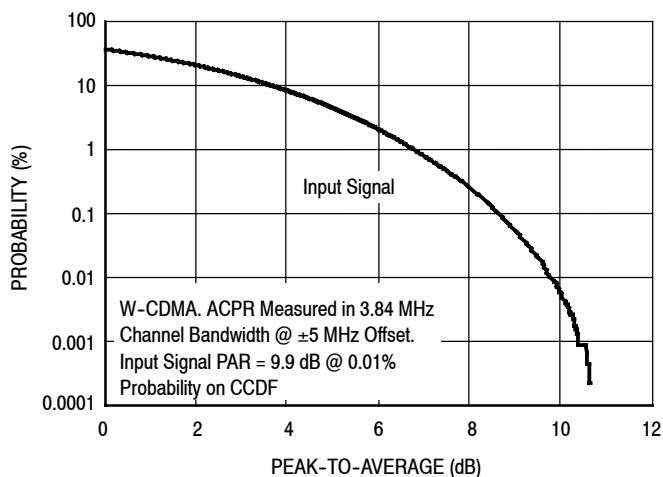

Figure 8. CCDF W-CDMA IQ Magnitude Clipping, Single-Carrier Test Signal

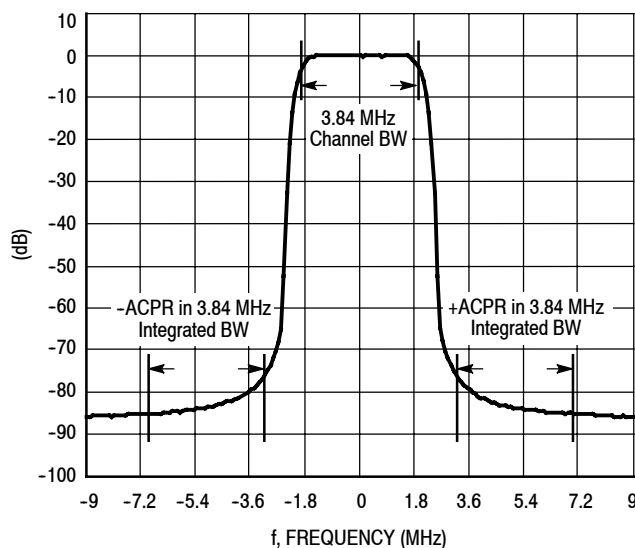

Figure 9. Single-Carrier W-CDMA Spectrum

$V_{DD} = 30 \text{ Vdc}$, $I_{DQ} = 1300 \text{ mA}$, $P_{out} = 50 \text{ W Avg.}$

| f MHz | Z_{source} Ω | Z_{load} Ω |
|----------|--------------------------|------------------------|
| 1880 | $3.52 - j5.54$ | $3.50 - j2.60$ |
| 1900 | $3.71 - j4.76$ | $3.42 - j2.64$ |
| 1920 | $3.97 - j3.96$ | $3.33 - j2.67$ |
| 1940 | $4.31 - j3.15$ | $3.23 - j2.69$ |
| 1960 | $4.76 - j2.29$ | $3.13 - j2.71$ |
| 1980 | $5.33 - j1.40$ | $3.02 - j2.71$ |
| 2000 | $6.08 - j0.48$ | $2.89 - j2.71$ |
| 2020 | $7.08 + j0.47$ | $2.77 - j2.71$ |
| 2040 | $8.39 + j1.41$ | $2.64 - j2.69$ |

Z_{source} = Test circuit impedance as measured from gate to ground.

Z_{load} = Test circuit impedance as measured from drain to ground.

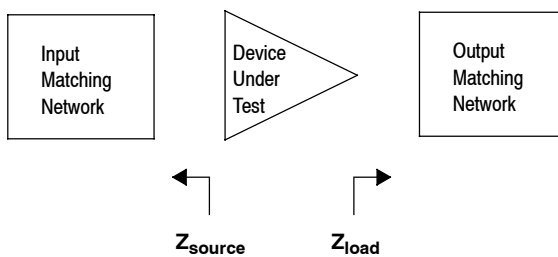

Figure 10. Series Equivalent Source and Load Impedance

$V_{DD} = 30 \text{ Vdc}$, $I_{DQ} = 1300 \text{ mA}$, Pulsed CW, $10 \mu\text{sec(ON)}$, 10% Duty Cycle

| f (MHz) | Z_{source} (Ω) | $Z_{\text{load}}^{(1)}$ (Ω) | Max Output Power | | | | | |
|------------|-------------------------------------|---|------------------|-----|--------------|-------|-----|--------------|
| | | | P1dB | | | P3dB | | |
| | | | (dBm) | (W) | η_D (%) | (dBm) | (W) | η_D (%) |
| 1930 | 5.06 - j7.33 | 2.07 - j3.37 | 54.3 | 269 | 49.2 | 55.2 | 331 | 51.2 |
| 1960 | 10.2 - j6.91 | 2.14 - j3.42 | 54.2 | 263 | 48.7 | 55.1 | 324 | 50.8 |
| 1995 | 13.1 - j0.18 | 2.39 - j3.53 | 54.1 | 257 | 48.5 | 55.0 | 316 | 49.7 |

(1) Load impedance for optimum P1dB power.

Z_{source} = Impedance as measured from gate contact to ground.

Z_{load} = Impedance as measured from drain contact to ground.

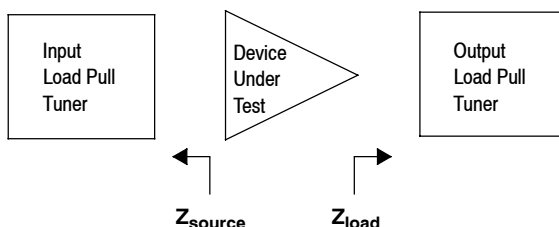

Figure 11. Load Pull Performance — Maximum P1dB Tuning

$V_{DD} = 30 \text{ Vdc}$, $I_{DQ} = 1300 \text{ mA}$, Pulsed CW, $10 \mu\text{sec(ON)}$, 10% Duty Cycle

| f (MHz) | Z_{source} (Ω) | $Z_{\text{load}}^{(1)}$ (Ω) | Max Drain Efficiency | | | | | |
|------------|-------------------------------------|---|----------------------|-----|--------------|-------|-----|--------------|
| | | | P1dB | | | P3dB | | |
| | | | (dBm) | (W) | η_D (%) | (dBm) | (W) | η_D (%) |
| 1930 | 5.06 - j7.33 | 2.44 - j1.46 | 52.7 | 186 | 58.9 | 53.4 | 219 | 61.4 |
| 1960 | 10.2 - j6.91 | 2.23 - j1.55 | 52.6 | 182 | 57.8 | 53.5 | 224 | 60.3 |
| 1995 | 13.1 - j0.18 | 2.31 - j1.63 | 52.6 | 182 | 56.6 | 53.3 | 214 | 59.8 |

(1) Load impedance for optimum P1dB efficiency.

Z_{source} = Impedance as measured from gate contact to ground.

Z_{load} = Impedance as measured from drain contact to ground.

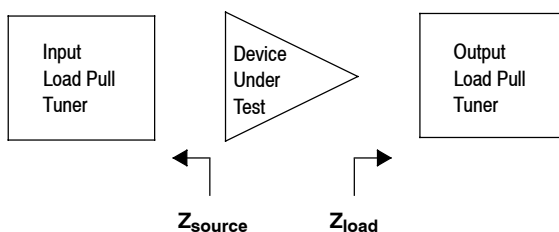
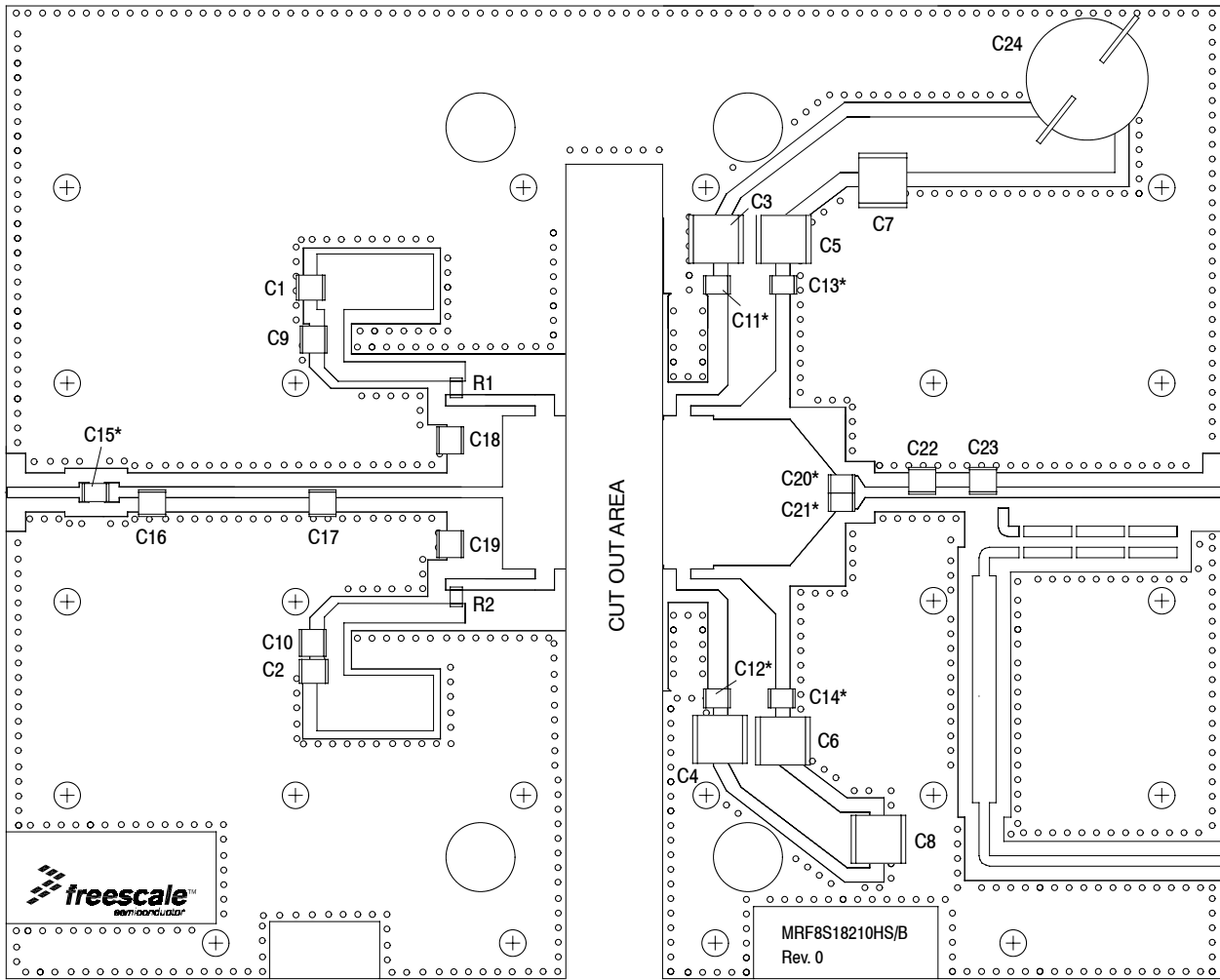

Figure 12. Load Pull Performance — Maximum Drain Efficiency Tuning



*C11, C12, C13, C14, C15, C20, and C21 are mounted vertically.

Figure 13. MRF8S18210WHSR3(WGHSR3) Test Circuit Component Layout — 1805 MHz - 1880 MHz

Table 6. MRF8S18210WHSR3(WGHSR3) Test Circuit Component Designations and Values — 1805 MHz - 1880 MHz

| Part | Description | Part Number | Manufacturer |
|-----------------------------|--|--------------------|--------------|
| C1, C2 | 2.2 μ F Chip Capacitors | C3225X7R2A225M | TDK |
| C3, C4, C5, C6, C7, C8 | 10 μ F Chip Capacitors | C5750X7S2A106MT | TDK |
| C9, C10, C11, C12, C13, C14 | 8.2 pF Chip Capacitors | ATC100B8R2BT500XT | ATC |
| C15 | 10 pF Chip Capacitor | ATC100B10R0BT500XT | ATC |
| C16, C17 | 2.2 pF Chip Capacitors | ATC100B2R2BT500XT | ATC |
| C18, C19, C22 | 0.8 pF Chip Capacitors | ATC100B0R8BT500XT | ATC |
| C20, C21 | 3.9 pF Chip Capacitors | ATC100B3R9BT500XT | ATC |
| C23 | 1.8 pF Chip Capacitor | ATC100B1R8BT500XT | ATC |
| C24 | 470 μ F, 63 V Electrolytic Capacitor | B41858-C8477-M000 | EPCOS |
| R1, R2 | 10 Ω , 1/4 W Chip Resistors | 232272461009 | Phycomp |
| PCB | 0.020", $\epsilon_r = 3.5$ | RO4350B | Rogers |

TYPICAL CHARACTERISTICS — 1805 MHz - 1880 MHz

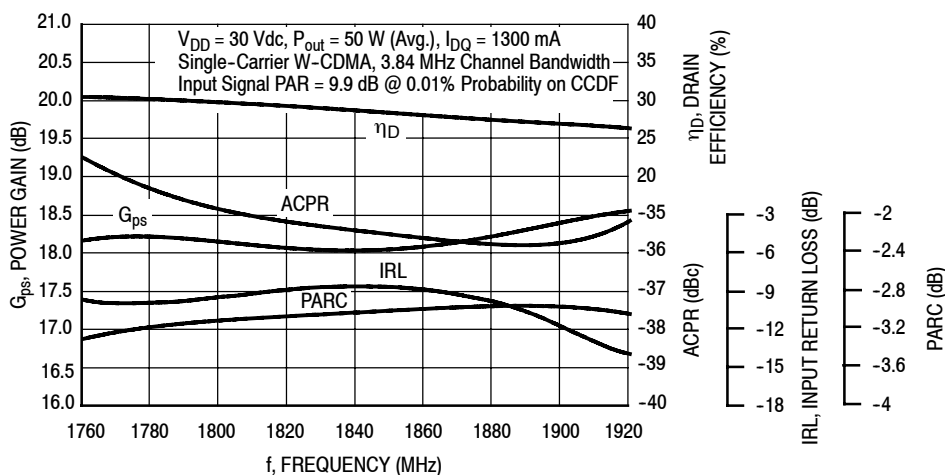

Figure 14. Output Peak-to-Average Ratio Compression (PARC) Broadband Performance @ $P_{out} = 50$ Watts Avg.

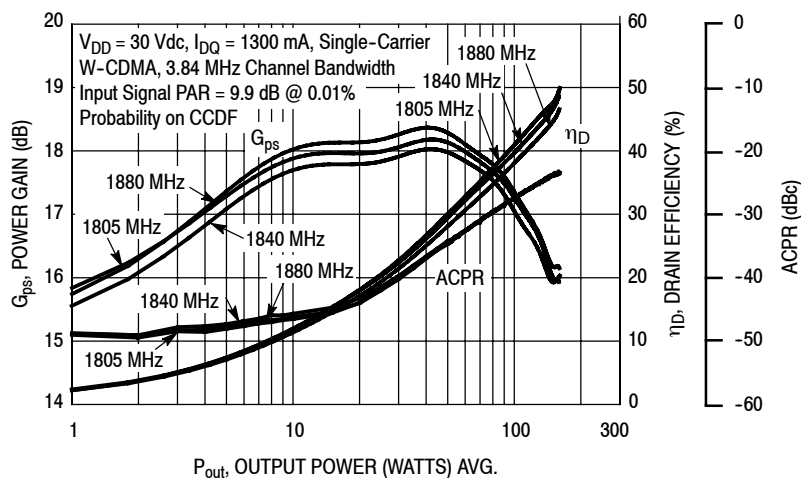

Figure 15. Single-Carrier W-CDMA Power Gain, Drain Efficiency and ACPR versus Output Power

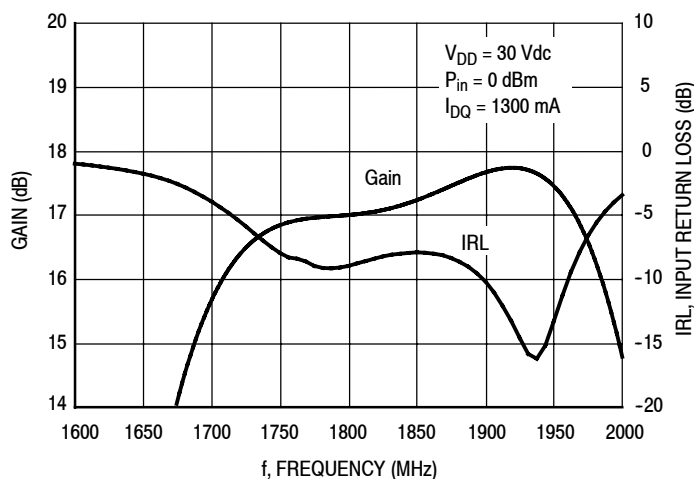

Figure 16. Broadband Frequency Response

$V_{DD} = 30 \text{ Vdc}$, $I_{DQ} = 1300 \text{ mA}$, $P_{out} = 50 \text{ W Avg.}$

| f MHz | Z_{source} Ω | Z_{load} Ω |
|----------|--------------------------|------------------------|
| 1760 | 1.81 - j4.25 | 3.09 - j2.28 |
| 1780 | 1.95 - j4.06 | 2.97 - j2.29 |
| 1800 | 2.13 - j3.89 | 2.85 - j2.29 |
| 1820 | 2.35 - j3.77 | 2.71 - j2.28 |
| 1840 | 2.61 - j3.70 | 2.58 - j2.25 |
| 1860 | 2.91 - j3.74 | 2.45 - j2.21 |
| 1880 | 3.19 - j3.90 | 2.32 - j2.16 |
| 1900 | 3.41 - j4.21 | 2.19 - j2.10 |
| 1920 | 3.48 - j4.64 | 2.06 - j2.03 |

Z_{source} = Test circuit impedance as measured from gate to ground.

Z_{load} = Test circuit impedance as measured from drain to ground.

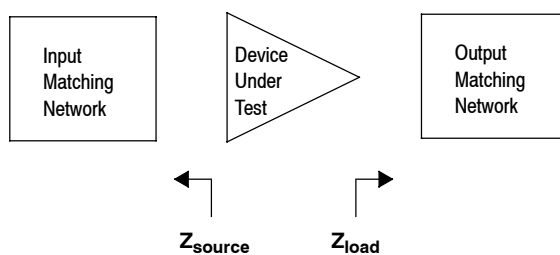

Figure 17. Series Equivalent Source and Load Impedance — 1805 MHz - 1880 MHz

$V_{DD} = 30 \text{ Vdc}$, $I_{DQ} = 1300 \text{ mA}$, Pulsed CW, $10 \mu\text{sec}(\text{on})$, 10% Duty Cycle

| f (MHz) | Z_{source} (Ω) | $Z_{\text{load}}^{(1)}$ (Ω) | Max Output Power | | | | | |
|------------|-------------------------------------|---|------------------|-----|--------------|-------|-----|--------------|
| | | | P1dB | | | P3dB | | |
| | | | (dBm) | (W) | η_D (%) | (dBm) | (W) | η_D (%) |
| 1805 | 0.79 - j4.26 | 1.77 - j2.83 | 54.4 | 275 | 50.5 | 55.3 | 339 | 52.0 |
| 1840 | 1.34 - j5.03 | 1.83 - j2.96 | 54.5 | 282 | 50.8 | 55.3 | 339 | 52.2 |
| 1880 | 2.15 - j5.84 | 1.89 - j2.98 | 54.4 | 275 | 51.0 | 55.3 | 339 | 51.8 |

(1) Load impedance for optimum P1dB power.

Z_{source} = Impedance as measured from gate contact to ground.

Z_{load} = Impedance as measured from drain contact to ground.

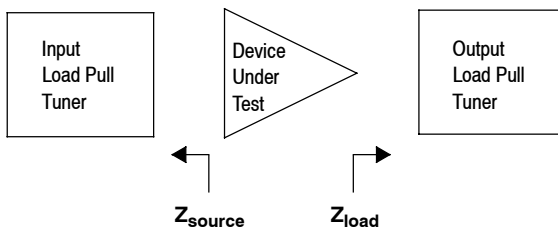

Figure 18. Load Pull Performance — Maximum P1dB Tuning — 1805 MHz - 1880 MHz

$V_{DD} = 30 \text{ Vdc}$, $I_{DQ} = 1300 \text{ mA}$, Pulsed CW, $10 \mu\text{sec}(\text{on})$, 10% Duty Cycle

| f (MHz) | Z_{source} (Ω) | $Z_{\text{load}}^{(1)}$ (Ω) | Max Drain Efficiency | | | | | |
|------------|-------------------------------------|---|----------------------|-----|--------------|-------|-----|--------------|
| | | | P1dB | | | P3dB | | |
| | | | (dBm) | (W) | η_D (%) | (dBm) | (W) | η_D (%) |
| 1805 | 0.79 - j4.26 | 3.02 - j1.55 | 53.0 | 200 | 59.6 | 53.4 | 219 | 62.5 |
| 1840 | 1.34 - j5.03 | 2.64 - j1.20 | 52.8 | 191 | 60.7 | 53.5 | 224 | 63.0 |
| 1880 | 2.15 - j5.84 | 2.40 - j1.51 | 53.1 | 204 | 59.7 | 53.2 | 209 | 62.2 |

(1) Load impedance for optimum P1dB efficiency.

Z_{source} = Impedance as measured from gate contact to ground.

Z_{load} = Impedance as measured from drain contact to ground.

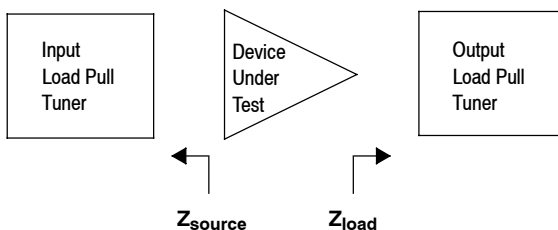
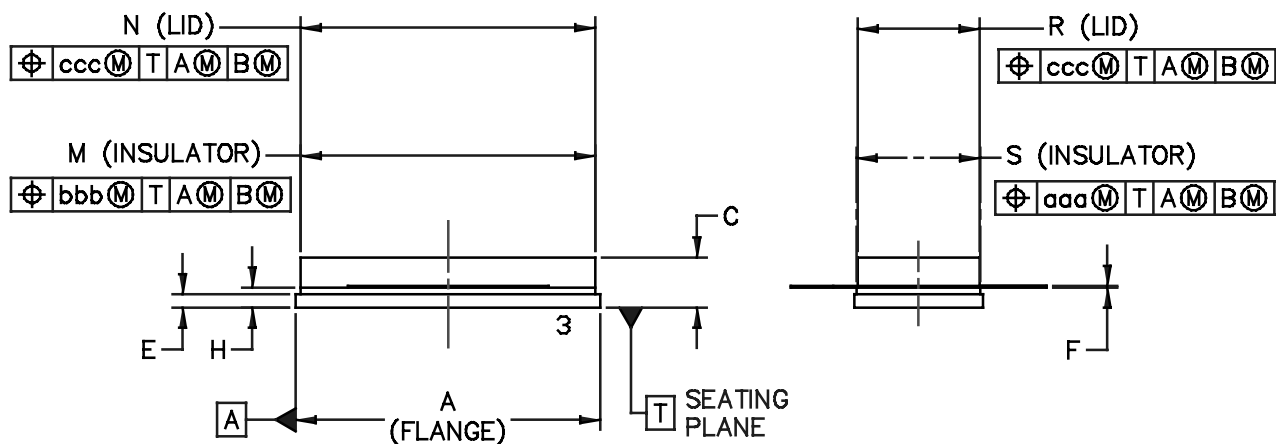
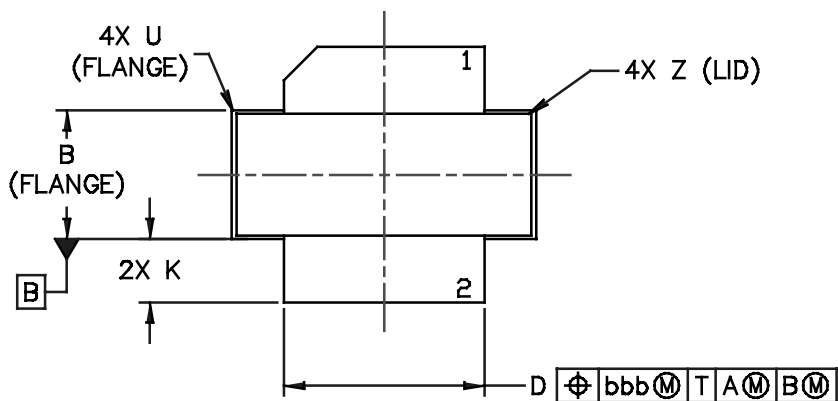

Figure 19. Load Pull Performance — Maximum Drain Efficiency Tuning — 1805 MHz - 1880 MHz

PACKAGE DIMENSIONS



| | | | | |
|---|--------------------|----------------------|----------------------------|--------|
| © FREESCALE SEMICONDUCTOR, INC. ALL RIGHTS RESERVED. | MECHANICAL OUTLINE | | PRINT VERSION NOT TO SCALE | |
| | TITLE: | | DOCUMENT NO: 98ASA00325D | REV: 0 |
| NI-880XS | | CASE NUMBER: 2194-01 | 10 MAY 2011 | |
| STANDARD: NON-JEDEC | | | | |

NOTES:

1. DIMENSIONING AND TOLERANCING PER ANSI Y14.5M–1994.
2. CONTROLLING DIMENSION: INCH.
3. DIMENSION H IS MEASURED .030 (0.762) AWAY FROM PACKAGE BODY.

| DIM | INCH | | MILLIMETER | | DIM | INCH | | MILLIMETER | |
|-----|------|--------|------------|---------|-----|------|--------|------------|---------|
| | MIN | MAX | MIN | MAX | | MIN | MAX | MIN | MAX |
| A | .905 | – .915 | 22.99 | – 23.24 | U | – | – .040 | – | – 1.02 |
| B | .380 | – .390 | 9.65 | – 9.91 | Z | – | – .030 | – | – 0.76 |
| C | .125 | – .170 | 3.18 | – 4.32 | aaa | – | .005 – | – | 0.127 – |
| D | .595 | – .605 | 15.11 | – 15.37 | bbb | – | .010 – | – | 0.254 – |
| E | .035 | – .045 | 0.89 | – 1.14 | ccc | – | .015 – | – | 0.381 – |
| F | .003 | – .006 | 0.08 | – 0.15 | – | – | – – | – | – – |
| H | .057 | – .067 | 1.45 | – 1.70 | – | – | – – | – | – – |
| K | .170 | – .210 | 4.32 | – 5.33 | – | – | – – | – | – – |
| M | .872 | – .888 | 22.15 | – 22.56 | – | – | – – | – | – – |
| N | .871 | – .889 | 22.12 | – 22.58 | – | – | – – | – | – – |
| R | .365 | – .375 | 9.27 | – 9.53 | – | – | – – | – | – – |
| S | .365 | – .375 | 9.27 | – 9.53 | – | – | – – | – | – – |

| | | |
|---|---------------------------|-----------------------------------|
| © FREESCALE SEMICONDUCTOR, INC. ALL RIGHTS RESERVED. | MECHANICAL OUTLINE | PRINT VERSION NOT TO SCALE |
| TITLE: NI–880XS | DOCUMENT NO: 98ASA00325D | REV: 0 |
| | CASE NUMBER: 2194–01 | 10 MAY 2011 |
| | STANDARD: NON–JEDEC | |

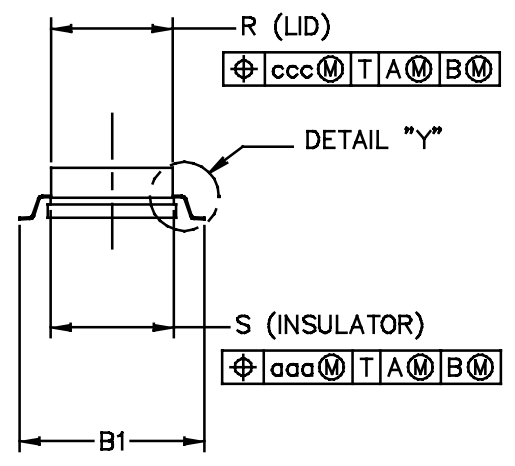
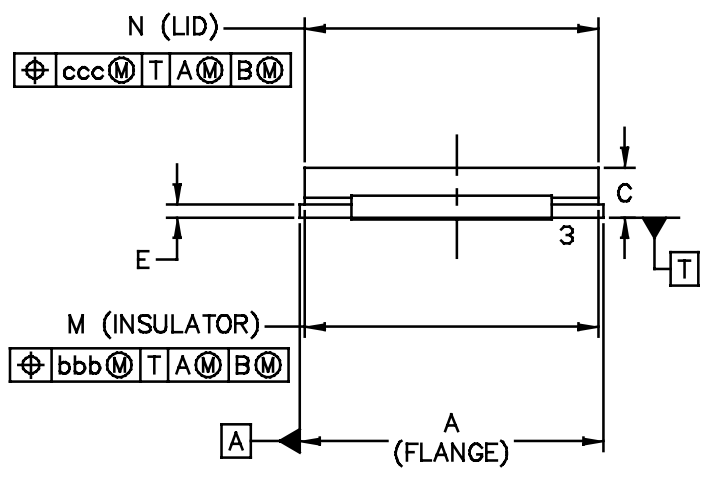
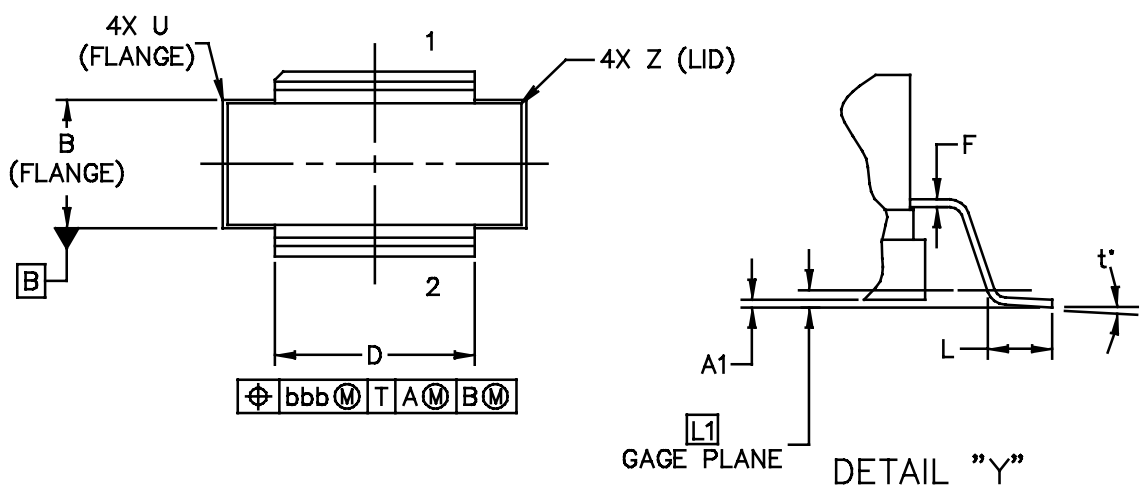

| | | | | | |
|---|--|--------------------|--------------------------|----------------------------|-------------|
| © FREESCALE SEMICONDUCTOR, INC. ALL RIGHTS RESERVED. | | MECHANICAL OUTLINE | | PRINT VERSION NOT TO SCALE | |
| TITLE: NI-880XS-2 GULL | | | DOCUMENT NO: 98ASA00456D | | REV: 0 |
| | | | CASE NUMBER: 2279-01 | | 23 FEB 2012 |
| | | | STANDARD: NON-JEDEC | | |

NOTES:

1. DIMENSIONING AND TOLERANCING PER ANSI Y14.5M-1994.
2. CONTROLLING DIMENSION: INCH.
3. DIMENSION A1 IS MEASURED WITH REFERENCE TO DATUM T. THE POSITIVE VALUE IMPLIES THAT THE PACKAGE BOTTOM IS HIGHER THAN THE LEAD BOTTOM.

| DIM | INCH | | MILLIMETER | | DIM | INCH | | MILLIMETER | |
|---|---------|-------|--------------------|---------|--------------------------|----------------------------|---------|-------------|---------|
| | MIN | MAX | MIN | MAX | | MIN | MAX | MIN | MAX |
| A | .905 | -.915 | 22.99 | - 23.24 | U | R.000 | - R.040 | R0.00 | - R1.02 |
| A1 | .000 | -.010 | 0.00 | - 0.25 | Z | - | - .030 | - | - 0.76 |
| B | .380 | -.390 | 9.65 | - 9.91 | t' | 0' | - 8' | 0' | - 8' |
| B1 | .549 | -.559 | 13.94 | - 14.20 | | | | | |
| C | .125 | -.170 | 3.18 | - 4.32 | | | | | |
| D | .595 | -.605 | 15.11 | - 15.37 | aaa | - | .005 - | - | 0.127 - |
| E | .035 | -.045 | 0.89 | - 1.14 | bbb | - | .010 - | - | 0.254 - |
| F | .003 | -.006 | 0.08 | - 0.15 | ccc | - | .015 - | - | 0.381 - |
| L | .038 | -.046 | 0.97 | - 1.17 | - | - | - - | - | - - |
| L1 | .01 BSC | | 0.25 BSC | | - | - | - - | - | - - |
| M | .872 | -.888 | 22.15 | - 22.56 | - | - | - - | - | - - |
| N | .871 | -.889 | 22.12 | - 22.58 | - | - | - - | - | - - |
| R | .365 | -.375 | 9.27 | - 9.53 | | | | | |
| S | .365 | -.375 | 9.27 | - 9.53 | | | | | |
| © FREESCALE SEMICONDUCTOR, INC. ALL RIGHTS RESERVED. | | | MECHANICAL OUTLINE | | | PRINT VERSION NOT TO SCALE | | | |
| TITLE: NI-880XS-2 GULL | | | | | DOCUMENT NO: 98ASA00456D | | | REV: 0 | |
| | | | | | CASE NUMBER: 2279-01 | | | 23 FEB 2012 | |
| | | | | | STANDARD: NON-JEDEC | | | | |

PRODUCT DOCUMENTATION, SOFTWARE AND TOOLS

Refer to the following documents, software and tools to aid your design process.

Application Notes

- AN1955: Thermal Measurement Methodology of RF Power Amplifiers

Engineering Bulletins

- EB212: Using Data Sheet Impedances for RF LDMOS Devices

Software

- Electromigration MTTF Calculator
- RF High Power Model
- .s2p File

Development Tools

- Printed Circuit Boards

For Software and Tools, do a Part Number search at <http://www.freescale.com>, and select the “Part Number” link. Go to the Software & Tools tab on the part’s Product Summary page to download the respective tool.

R5 TAPE AND REEL OPTION

R5 Suffix = 50 Units, 56 mm Tape Width, 13 inch Reel.

The R5 tape and reel option for MRF8S18210WHS and MRF8S18210WGHS parts will be available for 2 years after release of MRF8S18210WHS and MRF8S18210WGHS. Freescale Semiconductor, Inc. reserves the right to limit the quantities that will be delivered in the R5 tape and reel option. At the end of the 2 year period customers who have purchased these devices in the R5 tape and reel option will be offered MRF8S18210WHS and MRF8S18210WGHS in the R3 tape and reel option.

REVISION HISTORY

The following table summarizes revisions to this document.

| Revision | Date | Description |
|----------|-----------|---------------------------------|
| 0 | Apr. 2012 | • Initial Release of Data Sheet |

How to Reach Us:

Home Page:
freescale.com

Web Support:
freescale.com/support

Information in this document is provided solely to enable system and software implementers to use Freescale products. There are no express or implied copyright licenses granted hereunder to design or fabricate any integrated circuits based on the information in this document.

Freescale reserves the right to make changes without further notice to any products herein. Freescale makes no warranty, representation, or guarantee regarding the suitability of its products for any particular purpose, nor does Freescale assume any liability arising out of the application or use of any product or circuit, and specifically disclaims any and all liability, including without limitation consequential or incidental damages. "Typical" parameters that may be provided in Freescale data sheets and/or specifications can and do vary in different applications, and actual performance may vary over time. All operating parameters, including "typicals," must be validated for each customer application by customer's technical experts. Freescale does not convey any license under its patent rights nor the rights of others. Freescale sells products pursuant to standard terms and conditions of sale, which can be found at the following address: <http://www.reg.net/v2/webservices/Freescale/Docs/TermsandConditions.htm>.

Freescale, the Freescale logo, Altivec, C-5, CodeTest, CodeWarrior, ColdFire, C-Ware, Energy Efficient Solutions logo, Kinetis, mobileGT, PowerQUICC, Processor Expert, QorIQ, Qorivva, StarCore, Symphony, and VortiQa are trademarks of Freescale Semiconductor, Inc., Reg. U.S. Pat. & Tm. Off. Airfast, BeeKit, BeeStack, ColdFire+, CoreNet, Flexis, MagniV, MXC, Platform in a Package, QorIQ Qonverge, QUICC Engine, Ready Play, SafeAssure, SMARTMOS, TurboLink, Vybrid, and Xtrinsic are trademarks of Freescale Semiconductor, Inc. All other product or service names are the property of their respective owners.

© 2012 Freescale Semiconductor, Inc.