

PROD CODE	LOC	DIST	P	F	ZONE	LTR	DESCRIPTION	DATE	APPD	
3321	DF	XO				B	RELEASED PER 0600-1969-94	CT	2-95	JD

ASSEMBLED VIEW

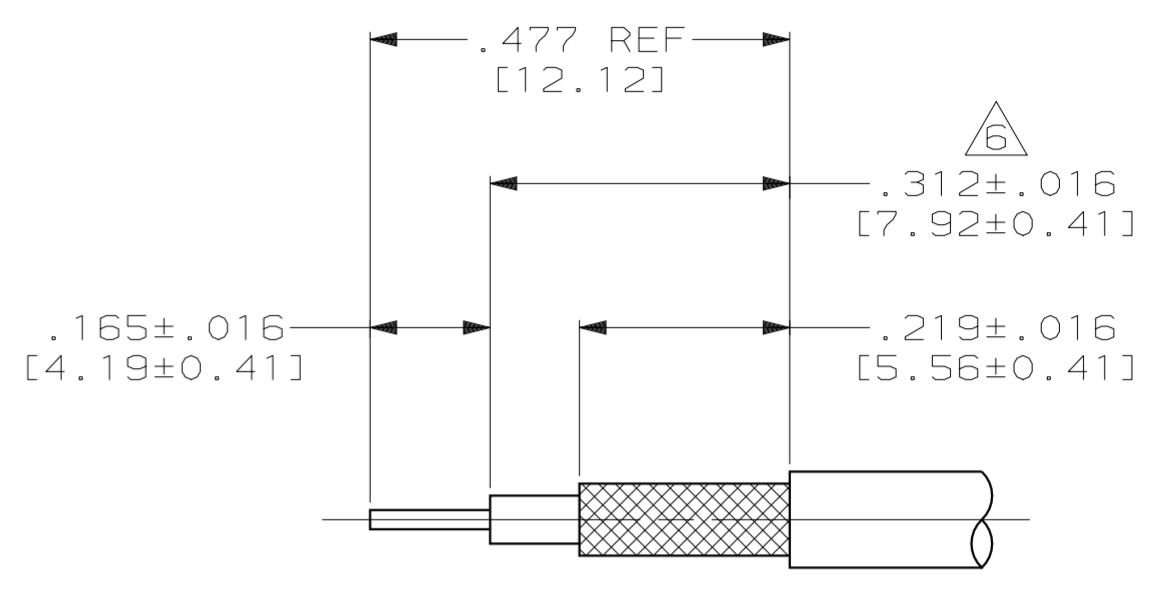

RECOMMENDED STRIP LENGTH
SCALE: N.T.S.

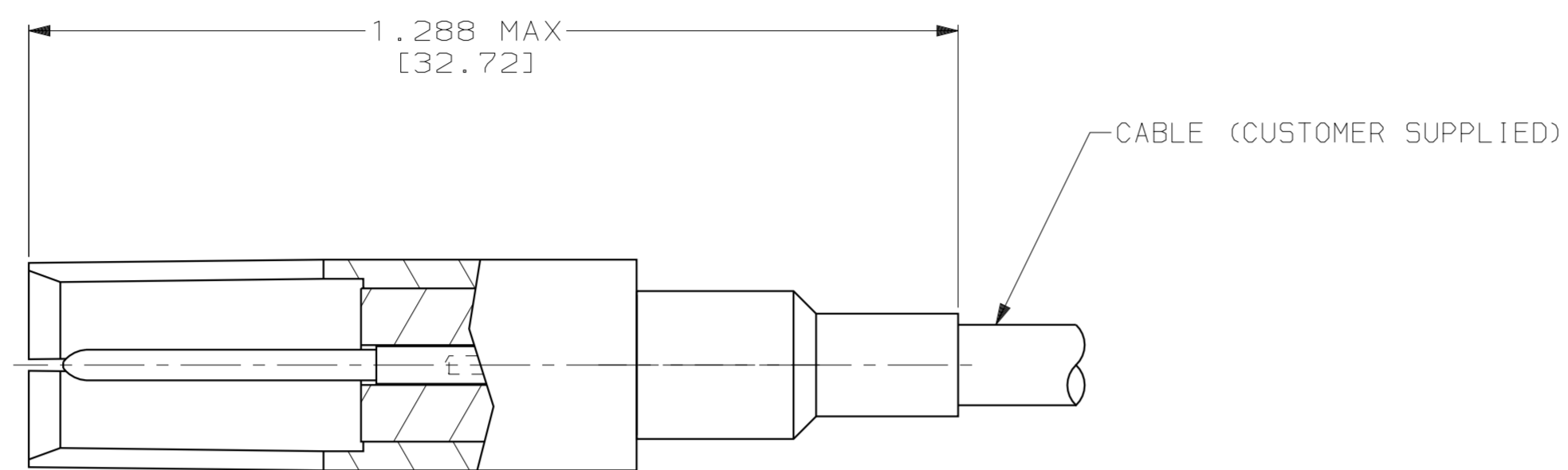
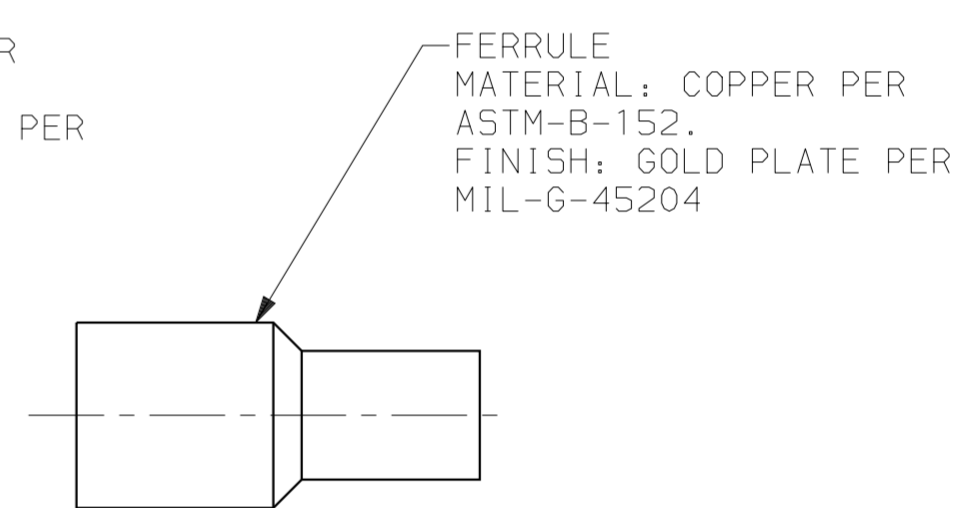
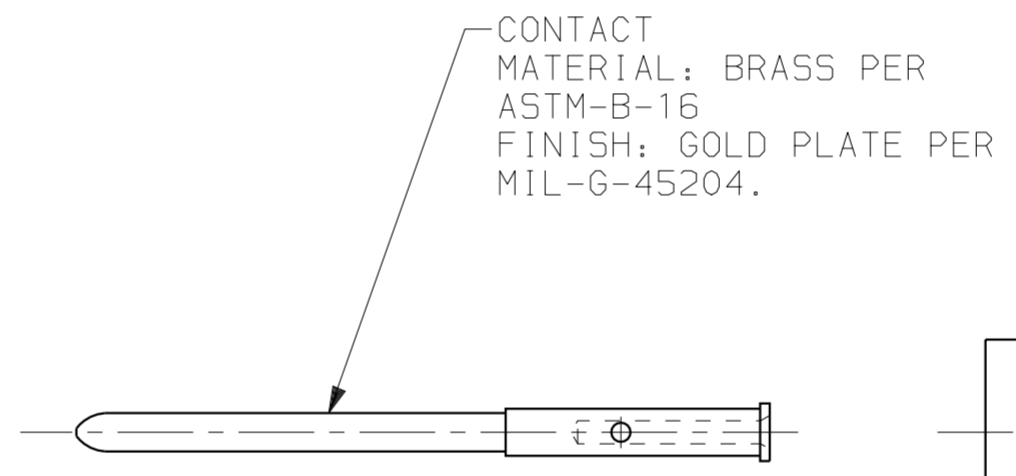
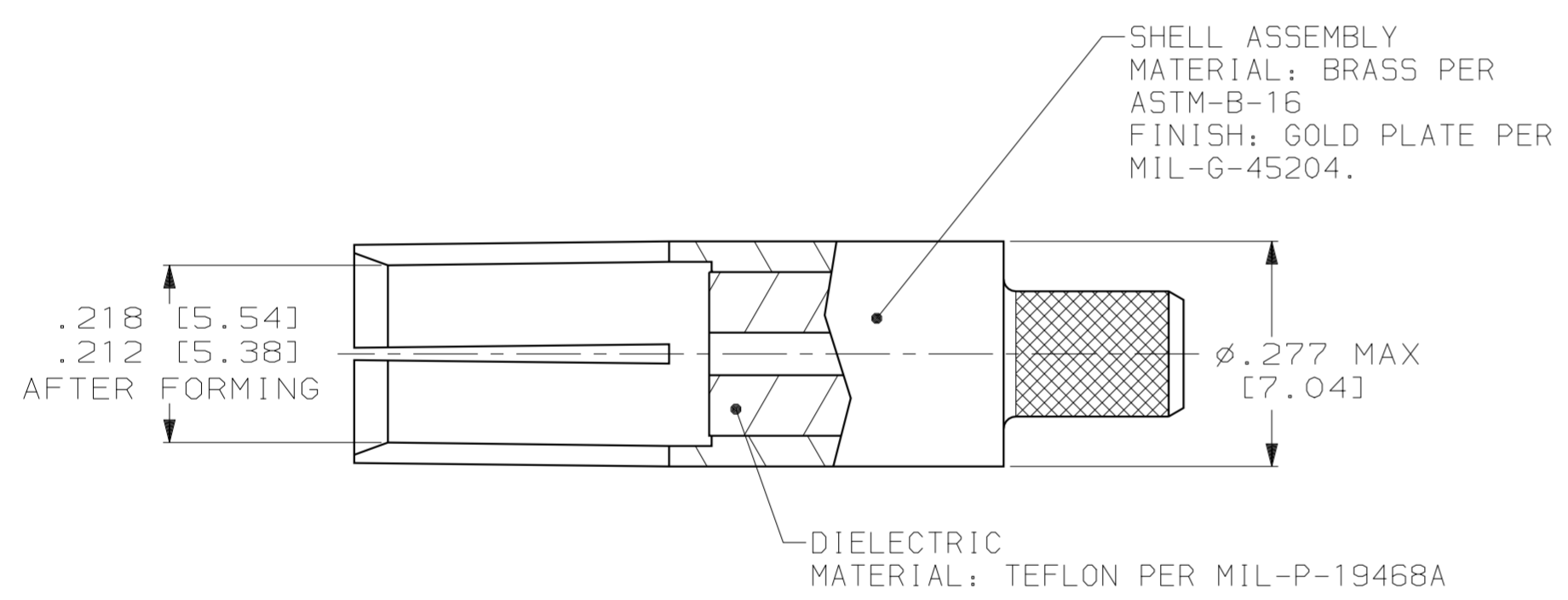

- FOR USE WITH 188A/u & 316/U COAX CABLE.
- FERRULE CRIMPING TOOL: AMP TOOL #220066-1 CRIMP C OR 220066-2 CRIMP C OR 220009-1 CRIMP C.
- CONTACT CRIMPING TOOL: M22520/2-01 OR AMP TOOL NUMBER 1-601966-6, SETTING NUMBER 5. DANIELS POSITIONER PART NO. K345 OR AMP TOOL NO. 1-601966-6.
- SEE I.S.2348.
- DANIELS MANUFACTURING CORP
2266 FRANKLIN ROAD
BLOOMFIELD HILLS, MI 48013
- OUTER JACKET OF CABLE MUST BE TRIMMED TO ALLOW PROPER INTER-PIN CONTACT LOCATION AFTER FERRULE CRIMP OPERATION.
- PARTS SHIPPED UNASSEMBLED AND CABLE IS SUPPLIED BY CUSTOMER.

THIS DRAWING IS A CONTROLLED DOCUMENT FOR AMP INCORPORATED. IT IS SUBJECT TO CHANGE AND THE CONTROLLING ENGINEERING ORGANIZATION SHOULD BE CONTACTED FOR THE LATEST REVISION.

DO NOT SCALE PRINT. UNLESS SPECIFIED DIMENSIONS IN INCHES [mm] TOLERANCES ON :	DR 2-1-95 C.C.THOMAS
2 PLC DEC ± -	CHK 2-2-95 J.DUNBAR
3 PLC DEC ± -	APPD 2-2-95 J.DUNBAR
ANGLES ± -	APPD 2-2-95 C.C.THOMAS
MATERIAL	PRODUCT SPEC
SEE CALLOUTS	108-12045
FINISH	APPLICATION SPEC
SEE CALLOUTS	-
	WEIGHT -

225791-9		
PART NO.		
AMP AMP Incorporated Harrisburg, PA 17105-3608		
NAME CONNECTOR, COAXIAL, RF SOCKET SIZE 5, ARINC (HEX CRIMP)		
SIZE	CAGE CODE	DRAWING NO
©	00779	©=225791-9
SCALE	5:1	SHEET 1 OF 1