

## 6-Line ESD-Protection Diode Array in LLP75

### Features

- Ultra compact LLP75-7L package
- 6-line ESD-protection
- Low leakage current  $I_R < 0.1 \mu\text{A}$
- Low load capacitance  $C_D = 13 \text{ pF}$
- ESD-immunity acc. IEC 61000-4-2
  - ± 15 kV contact discharge
  - ± 15 kV air discharge
- Working voltage range  $V_{RWM} = 5 \text{ V}$
- e4 - precious metal (e.g. Ag, Au, NiPd, NiPdAu) (no Sn)
- Compliant to RoHS directive 2002/95/EC and in accordance to WEEE 2002/96/EC



**RoHS**  
COMPLIANT  
**GREEN**  
(5-2008)\*\*

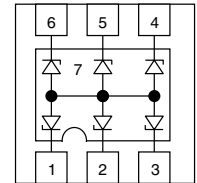
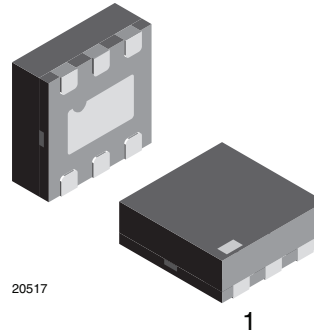

19371

### Marking (example only)

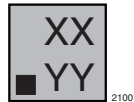

Dot = Pin 1 marking  
XX = Date code  
YY = Type code (see table below)

### Ordering Information

Device name	Ordering code	Taped units per reel (8 mm tape on 7" reel)	Minimum order quantity
VESD05A6A-HAF	VESD05A6A-HAF-GS08	3000	15000

### Package Data

Device name	Package name	Type code	Weight	Molding compound flammability rating	Moisture sensitivity level	Soldering conditions
VESD05A6A-HAF	LLP75-7L	AT	4.2 mg	UL 94 V-0	MSL level 1 (according J-STD-020)	260 °C/10 s at terminals

\*\* Please see document "Vishay Material Category Policy" [www.vishay.com/doc?99902](http://www.vishay.com/doc?99902)

## Absolute Maximum Ratings

Rating	Test condition	Symbol	Value	Unit	
Peak pulse current	BiAs-Mode: each input (pin 1 - pin 6) to ground (pin 2); acc. IEC 61000-4-5; $t_p = 8/20 \mu s$ ; single shot	$I_{PPM}$	2.5	A	
	BiSy-mode: each input (pin 1 - pin 6) to any other input pin. Pin 2 not connected. Acc. IEC 61000-4-5; $t_p = 8/20 \mu s$ ; single shot	$I_{PPM}$	2.5	A	
Peak pulse power	BiAs-mode: each input (pin 1 - pin 6) to ground (pin 2); acc. IEC 61000-4-5; $t_p = 8/20 \mu s$ ; single shot	$P_{PP}$	33	W	
	BiSy-mode: each input (pin 1 - pin 6) to any other input pin. Pin 2 not connected. Acc. IEC 61000-4-5; $t_p = 8/20 \mu s$ ; single shot	$P_{PP}$	43	W	
ESD immunity	Acc. IEC61000-4-2; 10 pulses BiAs-mode: each input (pin 1 - pin 6) to ground (pin 2)	Contact discharge	$V_{ESD}$	$\pm 15$	kV
		Air discharge	$V_{ESD}$	$\pm 15$	kV
	Acc. IEC 61000-4-2 ; 10 pulses BiSy-mode: each input (pin 1 - pin 6) to any other input pin. Pin 2 not connected	Contact discharge	$V_{ESD}$	$\pm 10$	kV
		Air discharge	$V_{ESD}$	$\pm 10$	kV
Operating temperature	Junction temperature	$T_J$	- 40 to + 125	$^{\circ}C$	
Storage temperature		$T_{STG}$	- 55 to + 150	$^{\circ}C$	

### Application Note:

- a) With the **VESD05A6A-HAF** 6 different signal or data lines can be clamped to ground. Due to the different clamping levels in forward and reverse direction the **VESD05A6A-HAF** clamping behavior is **B**idirectional and **A**symmetrical (**BiAs**).

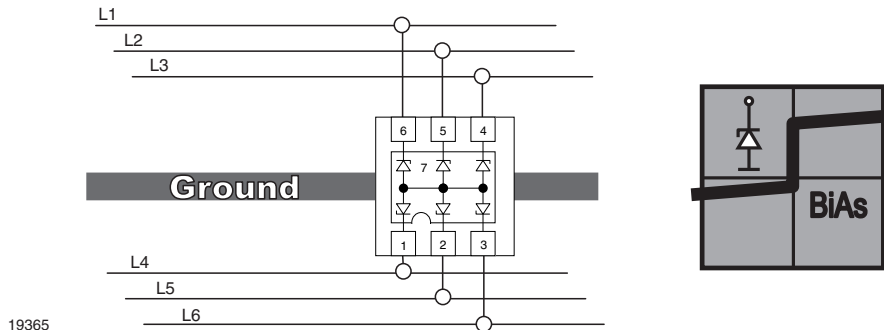

- b) If symmetrical clamping behaviour is required the **VESD05A6A-HAF** can also be used as a **B**idirectional **S**ymmetrical protection device protecting up to 5 lines. In this case pin no. 7 must not be connected.

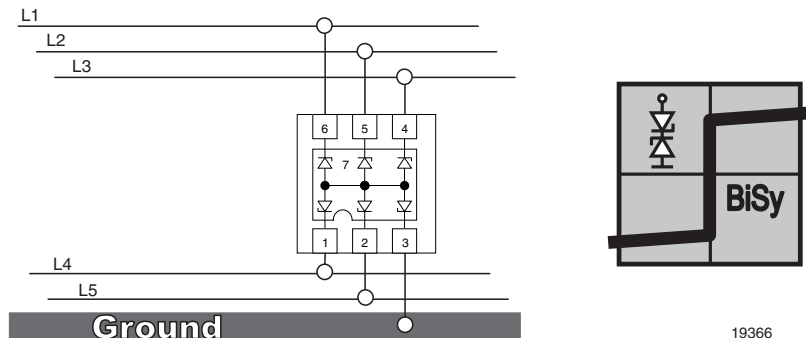

## Electrical Characteristics

Ratings at 25 °C, ambient temperature unless otherwise specified

### VESD05A6A-HAF

BiAs mode (between pin 1, 2, 3, 4, 5 or 6 and pin 7)

Parameter	Test conditions/remarks	Symbol	Min.	Typ.	Max.	Unit
Protection paths	Number of lines which can be protected	$N_{lines}$			6	lines
Reverse stand off voltage	at $I_R = 0.1 \mu A$	$V_{RWM}$	5			V
Max. reverse current	at $V_R = 5 V$	$I_R$		< 0.01	0.1	$\mu A$
Reverse break down voltage	at $I_R = 1 mA$	$V_{BR}$	6	6.7	7.5	V
Reverse clamping voltage	at $I_{PP} = 1 A$	$V_C$		9	10	V
	at $I_{PP} = I_{PPM} = 2.5 A$	$V_C$		12	13	V
Forward clamping voltage	at $I_{PP} = 1 A$	$V_F$		2	2.5	V
	at $I_{PP} = I_{PPM} = 2.5 A$	$V_F$		3.2	4	V
Line capacitance	at $V_R = 0 V; f = 1 MHz$	$C_D$		13	15	pF
	at $V_R = 2.5 V; f = 1 MHz$	$C_D$		8		pF

## Typical Characteristics

$T_{amb} = 25 \text{ }^\circ\text{C}$ , unless otherwise specified

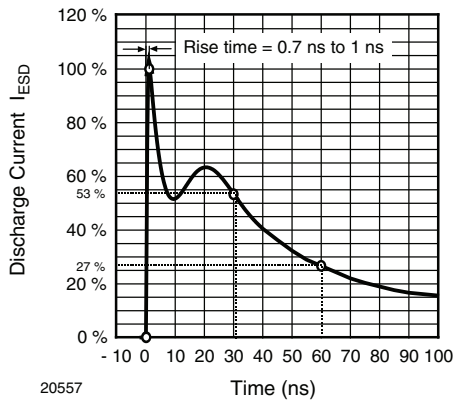

Figure 1. ESD Discharge Current Wave Form  
acc. IEC 61000-4-2 (330  $\Omega$ /150 pF)

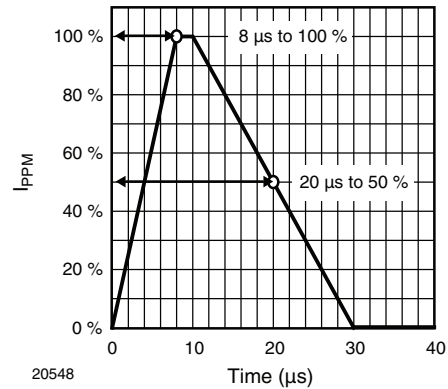

Figure 2. 8/20  $\mu s$  Peak Pulse Current Wave Form  
acc. IEC 61000-4-5

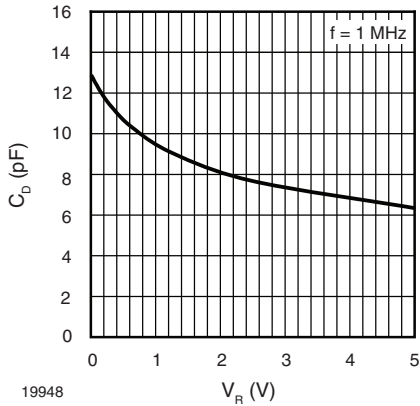

Figure 3. Typical Capacitance  $C_D$  vs. Reverse Voltage  $V_R$

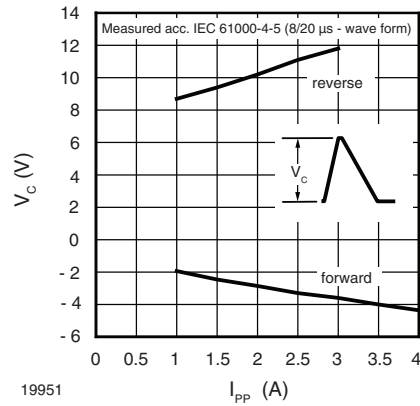

Figure 6. Typical Clamping Voltage vs. Peak Pulse Current  $I_{PP}$

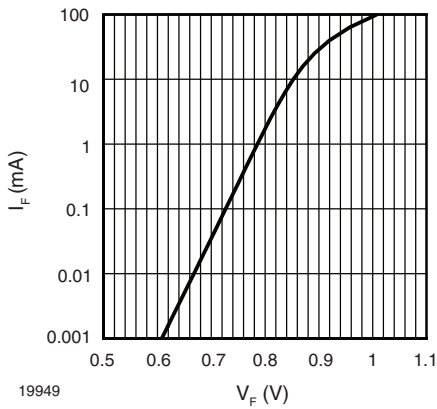

Figure 4. Typical Forward Current  $I_F$  vs. Forward Voltage  $V_F$

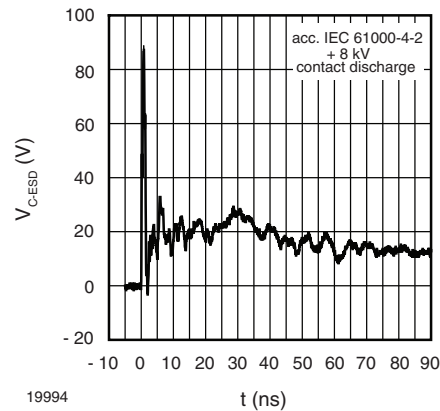

Figure 7. Typical Clamping Performance at + 8 kV Contact Discharge (acc. IEC 61000-4-2)

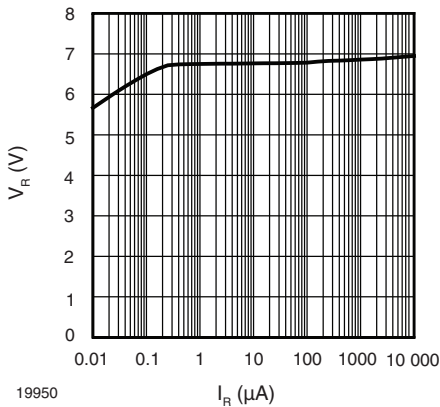

Figure 5. Typical Reverse Voltage  $V_R$  vs. Reverse Current  $I_R$

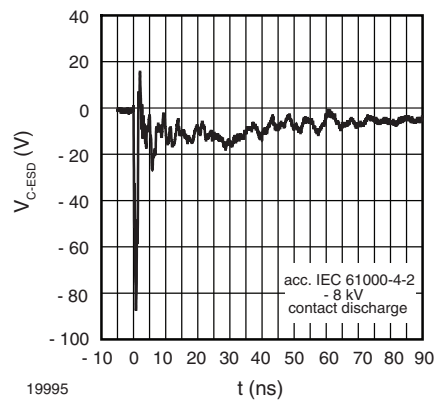

Figure 8. Typical Clamping Performance at - 8 kV Contact Discharge (acc. IEC 61000-4-2)

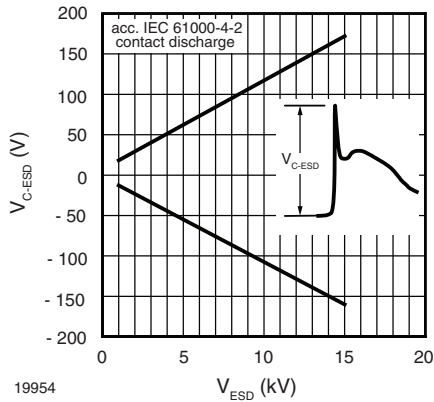
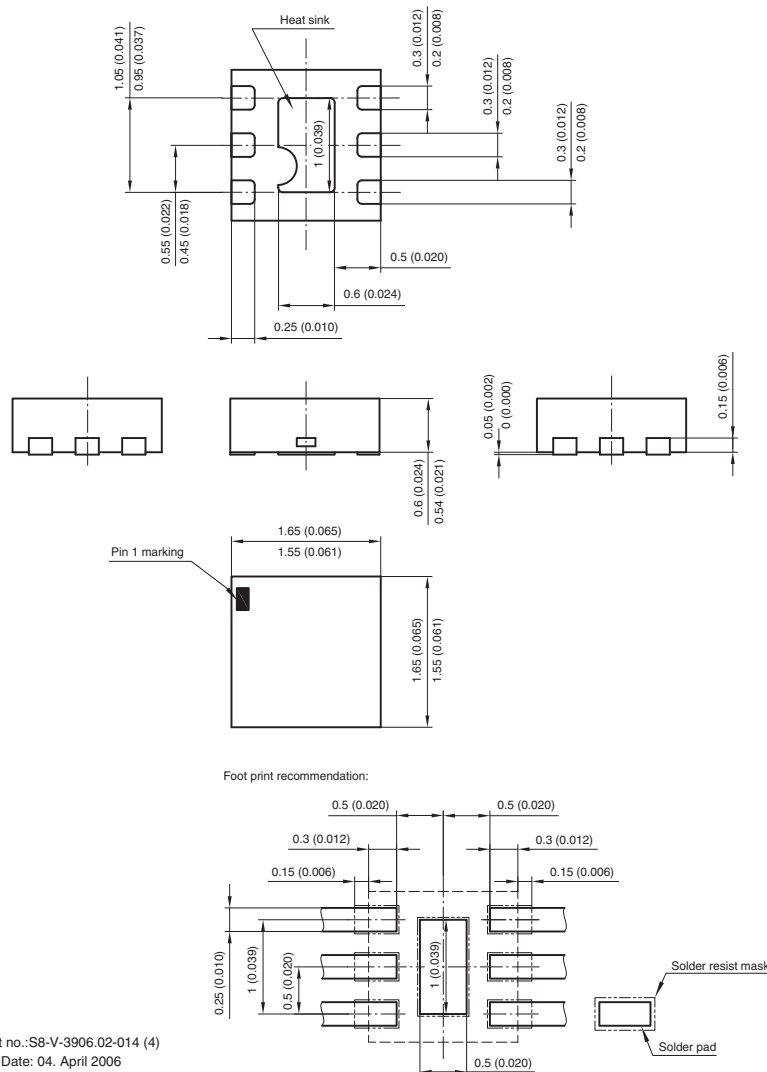

Figure 9. Typical max. Clamping Voltage at ESD Contact Discharge (acc. IEC 61000-4-2)

## Package Dimensions in millimeters (inches): LLP75-7L



Document no.: S8-V-3906.02-014 (4)  
 Created - Date: 04. April 2006  
 20500



## Disclaimer

ALL PRODUCT, PRODUCT SPECIFICATIONS AND DATA ARE SUBJECT TO CHANGE WITHOUT NOTICE TO IMPROVE RELIABILITY, FUNCTION OR DESIGN OR OTHERWISE.

Vishay Intertechnology, Inc., its affiliates, agents, and employees, and all persons acting on its or their behalf (collectively, "Vishay"), disclaim any and all liability for any errors, inaccuracies or incompleteness contained in any datasheet or in any other disclosure relating to any product.

Vishay makes no warranty, representation or guarantee regarding the suitability of the products for any particular purpose or the continuing production of any product. To the maximum extent permitted by applicable law, Vishay disclaims (i) any and all liability arising out of the application or use of any product, (ii) any and all liability, including without limitation special, consequential or incidental damages, and (iii) any and all implied warranties, including warranties of fitness for particular purpose, non-infringement and merchantability.

Statements regarding the suitability of products for certain types of applications are based on Vishay's knowledge of typical requirements that are often placed on Vishay products in generic applications. Such statements are not binding statements about the suitability of products for a particular application. It is the customer's responsibility to validate that a particular product with the properties described in the product specification is suitable for use in a particular application. Parameters provided in datasheets and/or specifications may vary in different applications and performance may vary over time. All operating parameters, including typical parameters, must be validated for each customer application by the customer's technical experts. Product specifications do not expand or otherwise modify Vishay's terms and conditions of purchase, including but not limited to the warranty expressed therein.

Except as expressly indicated in writing, Vishay products are not designed for use in medical, life-saving, or life-sustaining applications or for any other application in which the failure of the Vishay product could result in personal injury or death. Customers using or selling Vishay products not expressly indicated for use in such applications do so at their own risk and agree to fully indemnify and hold Vishay and its distributors harmless from and against any and all claims, liabilities, expenses and damages arising or resulting in connection with such use or sale, including attorneys fees, even if such claim alleges that Vishay or its distributor was negligent regarding the design or manufacture of the part. Please contact authorized Vishay personnel to obtain written terms and conditions regarding products designed for such applications.

No license, express or implied, by estoppel or otherwise, to any intellectual property rights is granted by this document or by any conduct of Vishay. Product names and markings noted herein may be trademarks of their respective owners.