

THIS DRAWING IS UNPUBLISHED.

RELEASED FOR PUBLICATION

20

© COPYRIGHT 20 BY -

ALL RIGHTS RESERVED.

REVISIONS

P	LTR	DESCRIPTION	DATE	DWN	APVD
	A	INITIAL	14NOV2016	BS	CW
	B	ECR-18-003111	23MAY2018	BS	CW

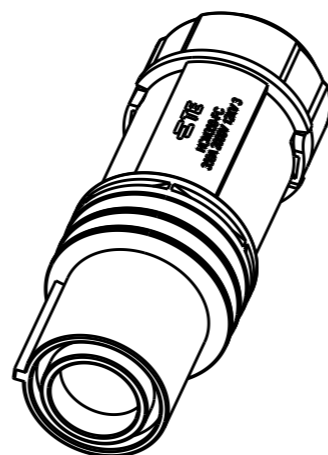
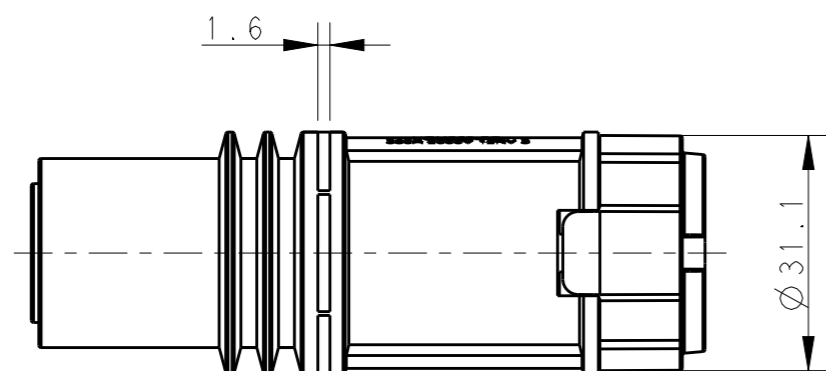
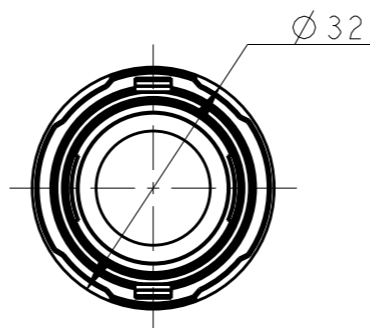
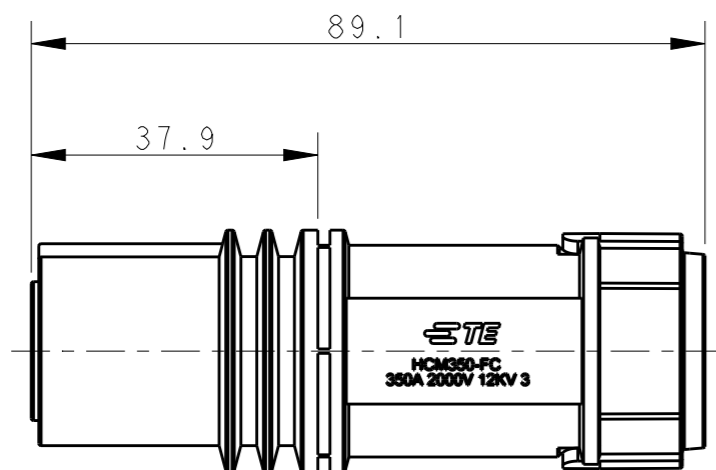

NOTES:

- TECHNICAL CHARACTERISTICS:
 INSULATION MATERIAL: PA
 RATED VOLTAGE: 2000V
 RATED CURRENT: 350A
 RATED IMPULSE VOLTAGE: 12KV
 POLLUTION DEGREE: 3
 FLAMMABILITY: UL94V-0
 WIRE RANGE: 35-120 mm²
 CONTACT TYPE: CRIMP CONTACT
- CONTACT NEED TO BE ORDERED SEPARATELY.
 (ORDER No. REFER TO DRAWING:T2193502XXX000)

注释:

- 技术参数:
 绝缘材料: PA
 额定电压: 2000V
 额定电流: 350A
 额定脉冲电压: 12KV
 污染等级: 3
 阻燃等级: UL94V-0
 接线范围: 35-120 mm²
 接线类型: 冷压接
- 端子需要单独订购.
 (订货号参考图面: T2193502XXX000)

T2193503201-000	HCM350-FC	HCM350 FEMALE INSERT, CRIMP HCM350母插、冷压型
PART NUMBER 零件料号	PART DESCRIPTION 零件描述	

THIS DRAWING IS A CONTROLLED DOCUMENT.		DWN BELL SU 14NOV2016	 TE Connectivity	
DIMENSIONS: mm		CHK KYLE ZENG 14NOV2016		
TOLERANCES UNLESS OTHERWISE SPECIFIED:		APVD CHRIS WANG 14NOV2016	NAME HCM350-FC	
0 PLC ±- 1 PLC ±- 2 PLC ±- 3 PLC ±- 4 PLC ±- ANGLES ±-		PRODUCT SPEC 108-137073	DRAWING NO	
MATERIAL		APPLICATION SPEC 114-137073	SIZE A3	RESTRICTED TO
FINISH		WEIGHT	CAGE CODE	SCALE
		CUSTOMER DRAWING	①-T2193503201000	1:1
			SHEET 1 OF 1	REV B