

THIS DOCUMENT IS THE PROPERTY OF KEYSTONE ELECTRONICS CORP. AND SHALL NOT BE REPRODUCED, DISTRIBUTED OR USED AS A BASIS FOR MANUFACTURE WITHOUT PRIOR WRITTEN PERMISSION FROM KEYSTONE ELECTRONICS CORP.

REQUIRED SPACING FOR (2) 'AAAA' CLIPS

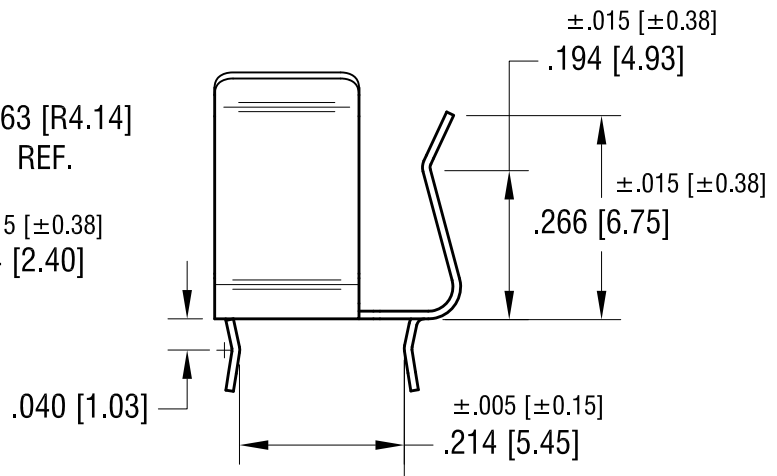
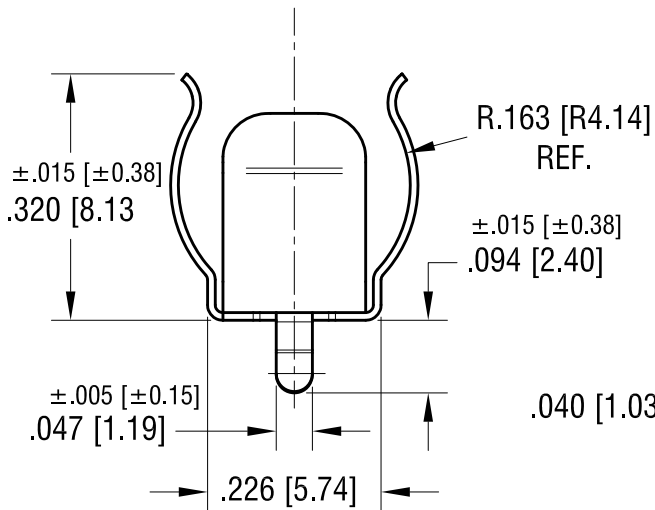
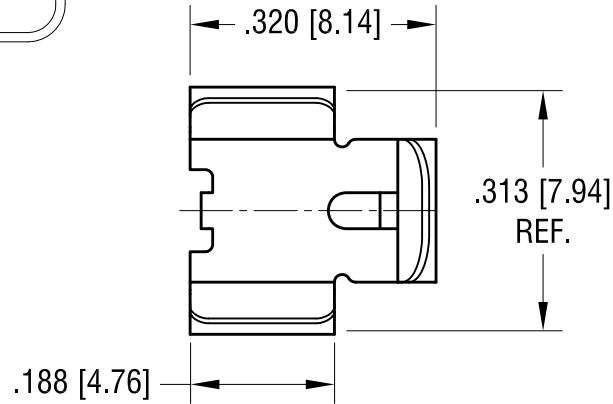
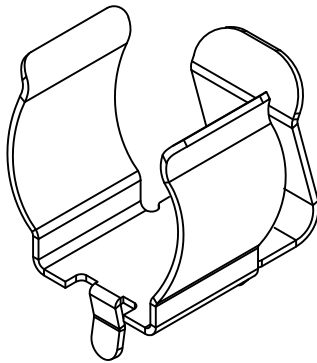
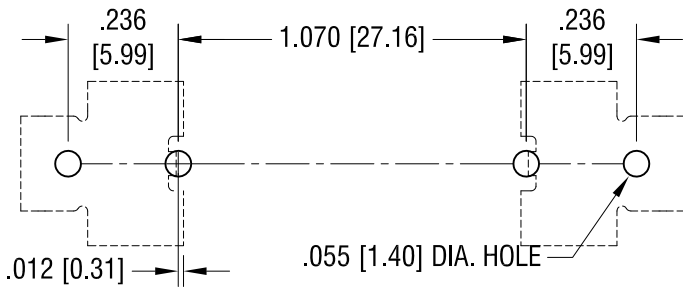

NOTE:

1. HEAT TREAT TO SPRING TEMPER

12.23.10	CHANGE AS PER ECN 10-091	E
10.1.09	CHANGE AS PER ECN 09-141	D
9.14.09	CHANGE AS PER ECN 09-126	C
6.05.09	CHANGE AS PER ECN 09-050	B
11.12.04	CHANGE AS PER ECN 04-138	A
DATE	DESCRIPTION	REV.

KEYSTONE ELECTRONICS CORP.			
www.keyelco.com • ASTORIA, N.Y. 11105-2017 • Tel (718) 956-8900			
PART NAME		'AAAA' PC BATTERY CLIP	
MATERIAL		.010 [.25] TH'K ANNEALED SPRING STEEL	
FINISH		DRN BY	DATE
TIN NICKEL PLATE		BOONE	2.1.02
		APP'D	SCALE
		LN	4X
TOLERANCES	INCH [MM]	CODE	DWG NO.
DECIMAL	±.010 [±0.25]	C	
ANGULAR	± 1°		
UNLESS OTHERWISE SPECIFIED			51