

	A	B	C	D	E	F	G
MD	Description		Please follow Pulse Limits for the hazardous substances (RoHS, halogens) in the document "Pulse Hazardous Substances (HS) Limits (RPGE002-03)" and "Vendor Survey Questionnaire, Material Composition (LDM-SAF-L0040)".	Reliability Test Spec according to WIHS7.5.33 (Reliability Test Working Instruction) Default test standard is Test Standard A if no definition			
P3	Change the Logo						

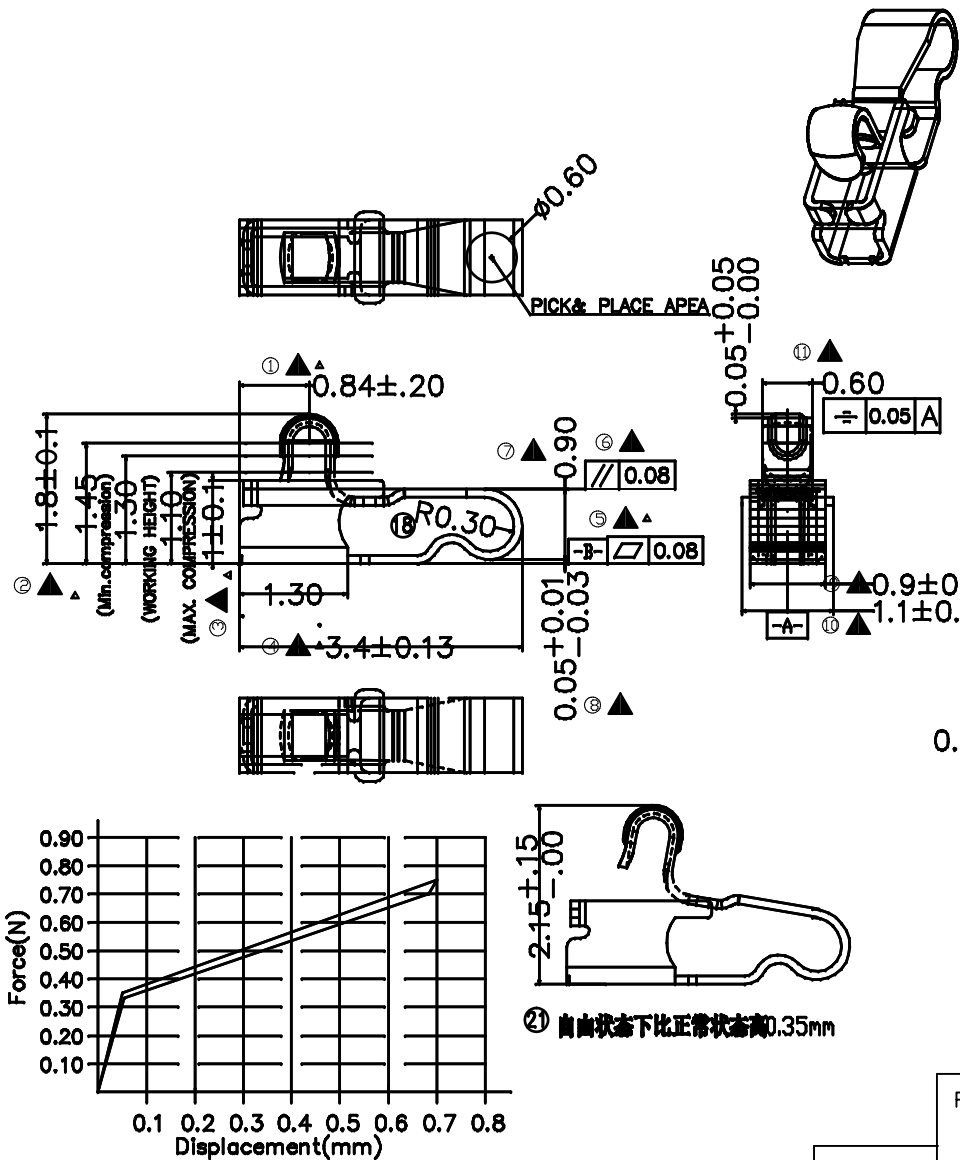

- NOTES: UNLESS OTHERWISE SPECIFIED
- DIM. MARKED TO BE CHECKED.
 - MATERIAL: C17480-H T=0.1±0.005
 - NO CRACK APPEARS ON CONTACT BALL SHAPE.
 - NO LINES APPEARS ON BENDING AREA.
 - ALL UNSPECIFIED RADII TO BE 0.05 MAXIMUM.
 - BURR: 0.02MAX; CUMBER: 3MM MAX/500MM; TWIST: 20°/500MM.
 - PRE-LOAD FORCE: 0.35N ON CONTACT POINT
 - WITH 20TIME/MINUTE TEST SPEED COMPRESSED TO 0.8MM, KEEP THREE SECONDS, FORCE VALUE IS GREATER THAN 0.75N
 - 镀金要求: 接触点区域: Au>=5u" inches min "Ni">=47u"-120u" inches"

- 焊接区域: Au>=1u" inches min"
水性耐孔剂耐孔。
10. 产品毛刺不可超过0.05mm, 未标注的锐角/尖角按照0.2mm管控
11. 产品需符合HSF标准
12. 标注▽为重点尺寸, 首批批量交货需做MinCPK, CPK值≥1.67, 每次交货需附尺寸检验报告

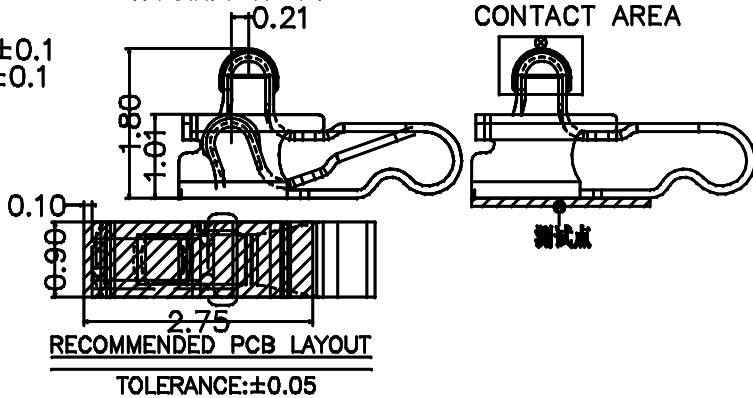

Confidential
This is a proprietary information of Pulse Suzhou.
No reproduction/copying is allowed without permission.

Functional Characteristics Key (Cpk requirement: Cpk) >
 ● Process Capability Studies required (total pcs)
 ● Ongoing Statistical Process Control Required (total pcs)
 ● Critical dimension need to be measured, no CPK requirement (total pcs)

- .X± 0.15
- .XX± 0.10
- .XXX± 0.05
- X: ± 5°

PULSE (SUZHOU) WIRELESS PRODUCTS CO.,LTD.		THIRD ANGLE PROJECTION		SHEET NUMBER 1 / 1				
 99 HUOLU RD. SUZHOU NEW DISTRICT 215009 P.R.CHINA		GENERAL TOLERANCE						
		CUSTOMER NUMBER						
SCALE 4,000		DESIGN	JACKIE	JUN-28-18				
		CHECKED	MARK	Nov-22-17				
		APPROVED	JAMES	Nov-22-17	P3	March-07-19	CHRIS	
DOCUMENT NUMBER SW0172N		PART VERSION	P01	DOCUMENT VERSION	P3	P2	Oct-26-18	Chris
ITEM TX15004-001(CLIP)					P1	JUN-28-18	JACKIE	
					MOD	DATE	NAME	