

Rev.	Description of revision	Date	By
Ø	Refer from QP-14145A (FAW-1233-TX) and use -01 for and -02 for 200mm.	25/7/2015	Wittaya

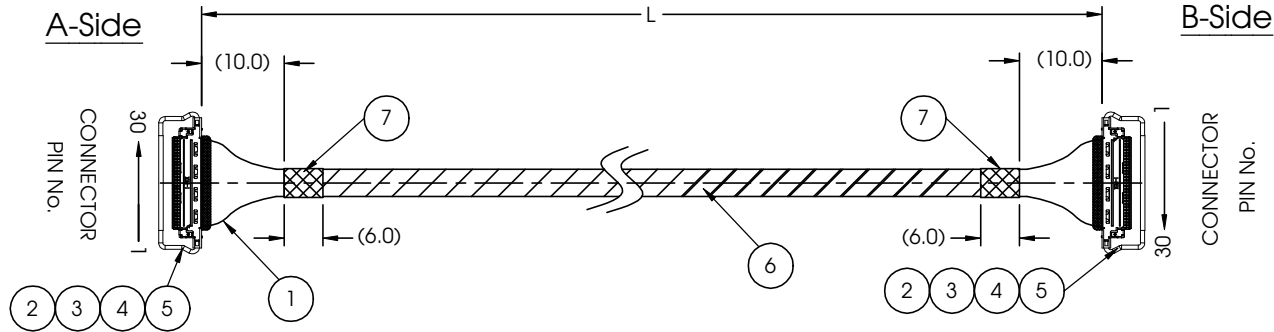
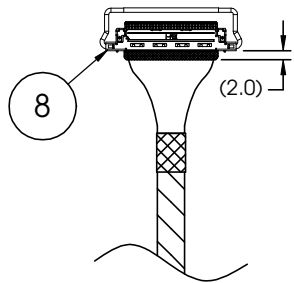
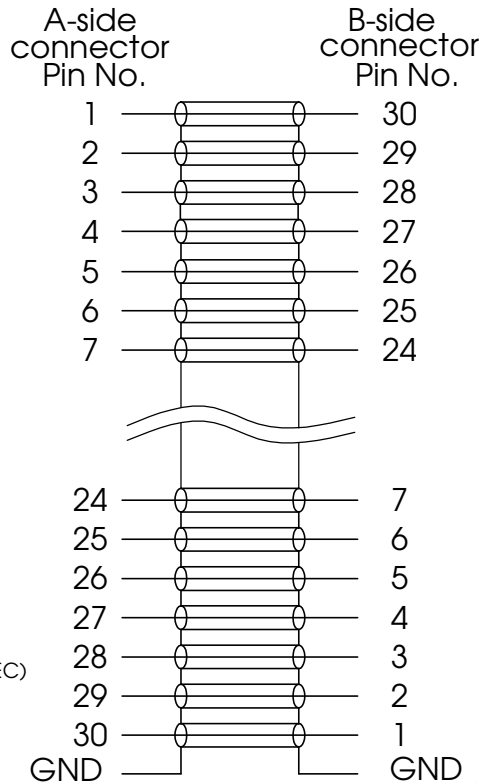

Fig. 1 Applying UV resin



WIRING



Unit:mm

Description	L (mm)
FAW-1233-01	100.0±5.0
FAW-1233-02	200.0±5.0
FAW-1233-03	300.0±10.0
FAW-1233-04	400.0±15.0
FAW-1233-05	500.0±15.0

NOTE.

1. Apply UV resin at the end of connector to cover cables both sides of the cable assembly (Fig.1).

Test:

- Insulation resistance:Min 50M ohms.(DC.300V Megaohm tester,0.1 SEC)
- Dielectric strength: No break down.(AC100V 0.1 SEC)
- Continuity wire collation: To be correct as shown in wiring.

8	UV RESIN	2	LOCTITE P/N : 352 LIGHT CURE
7	TAPE	2	CHUKOH P/N: ASF-116T
6	TAPE	1	CHUKOH P/N: SEF-110
5	FLAT COPPER WIRE	4	GROUND BAR
4	PULL BAR	2	I-PEX P/N : 2766-0301
3	SHIELD PLATE	2	I-PEX P/N : 2764-0301-002
2	CONNECTOR	2	I-PEX P/N : 20634-130T-02
1	CABLE	30	UL10231 AWG40 MCX (Z=50ohm)
ITEM	DESCRIPTION	Q'TY	REMARK

Title  
**FJK P/N: FAW-1233-XX**

Drawn by **Wittaya** Drawing No. **QP-14217**

Date **15 Jul.2016** Fujikura Electronics (Thailand) Ltd.