

AVERY DENNISON MARKETING SPECIFICATION

THE SUBJECT MATTER DISCLOSED HEREIN EMBODIES PROPRIETARY INFORMATION WHICH IS THE CONFIDENTIAL PROPERTY OF THE AVERY DENNISON CO. NONE OF WHICH SHALL BE COPIED, REPRODUCED, DISCLOSED TO OTHERS, PUBLISHED OR USED IN WHOLE OR IN PART, FOR ANY PURPOSE OTHER THAN THAT FOR WHICH IT IS BEING MADE AVAILABLE WITHOUT THE EXPRESS ADVANCE WRITTEN PERMISSION OF A DULY AUTHORIZED AGENT OF THE COMPANY. THIS DOCUMENT IS THE PROPERTY OF THE AVERY DENNISON CO. AND IS TO BE RETURNED TO THE COMPANY ON DEMAND.

HISTORY

| REV. | DATE | DESCRIPTION |
|------|----------|---|
| Q | 09.24.13 | UPDATE BALLOON 5; ADDED UNITS |
| R | 09.18.14 | ADDED OPER. TEMP, UL LOGO ADDED NOTE: CHG DIM 1 TO BE TAKEN FROM THE BOTTOM OF HEAD; ADDED NOTE TO DIM 5, DIMENSION TAKEN FROM CROWN OF THE FIRST TOOTH. |

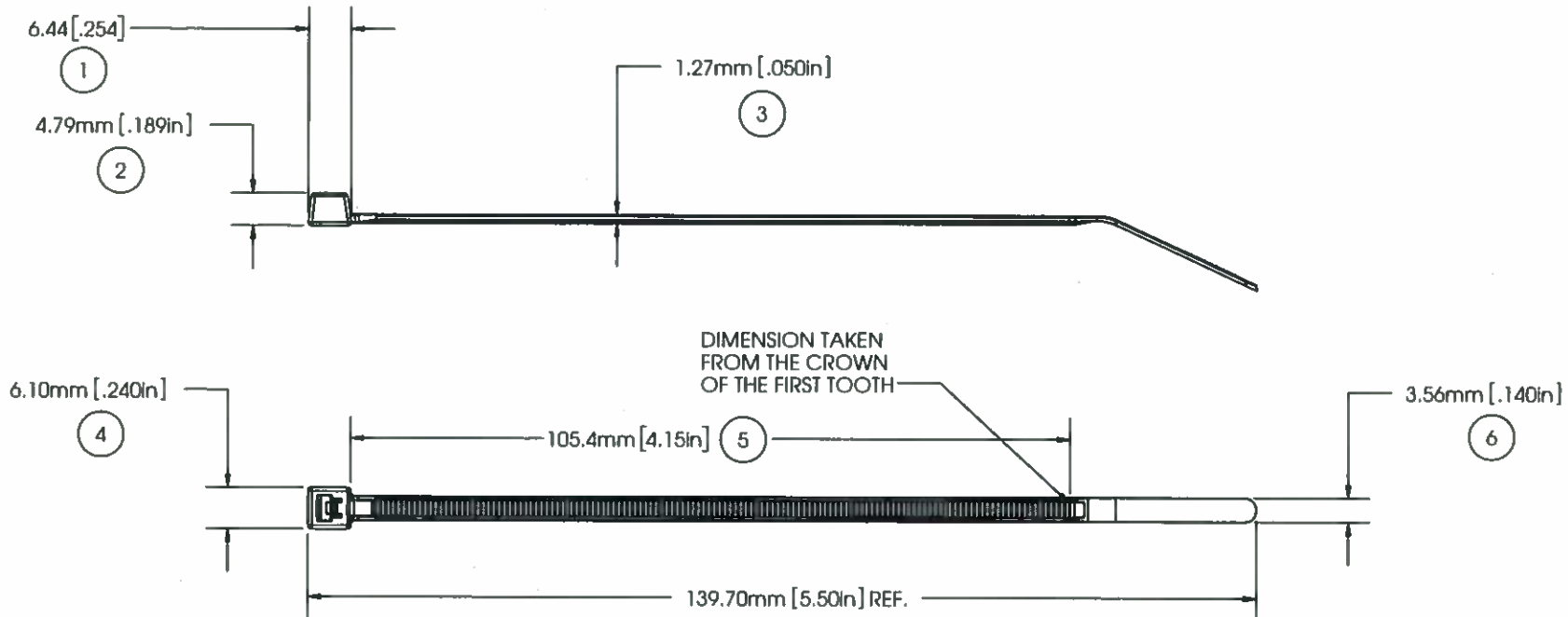

DIMENSION TAKEN FROM THE CROWN OF THE FIRST TOOTH

NOTE: THESE CABLE TIES ARE UV RESISTANT AND HAVE A FLAMMABILITY RATING OF V-2



LISTED
POSITIONING DEVICE
E57800
TYPE 21

| | |
|-------------------------|--|
| MILITARY STANDARD: | MS-3367-5-0 |
| LOOP TENSILE STRENGTH: | 40 LBF / 180N MIN. PER AS-23190 |
| OPERATING TEMP: | -40°F(-40°C) TO 176°F(80°C) |
| MIN. INSTALLATION TEMP: | 32°F(0°C) |
| WEIGHT: | 0.025 OZ./0.70 GRAMS |
| BUNDLE DIAMETER: | Ø 1.6MM TO Ø 31.8MM |
| TOOL: | 12001 - HAND INSTALLATION TOOL 12500 - PNUEM. INSTALLATION TOOL |
| TOOL TENSION SETTING: | 3-5 |
| PACKAGING: | 1000/BAG, 5000/CASE |

APPROVALS: ENG. APPR. *[Signature]* 9/18/14
Q.A. APPR. *[Signature]* 9/18/14



FASTENER DIVISION
FITCHBURG, MA 01420 U.S.A.
TEL. 1-800-225-5913
FAX. 978-353-8157

| | | | | |
|---------------------------|--------------|------------------------------|----------------------------------|----------|
| SPECIFIED TOLERANCES ARE: | | MATERIAL | DESCRIPTION | |
| .XX ± .03 IN. | .X ± .7 MM | NYLON 6/6, WEATHER RESISTANT | 5.5" CABLE TIE, INTERMED. | |
| .XXX ± .010 IN. | .XX ± .25 MM | COLOR | STOCK NO. | REV. |
| ANGULAR: ± 2° | | BLACK | 08431-0 | R |

5

4

3

2

1