

**2-PHASE HALF-WAVE HIGH VOLTAGE MOTOR PRE-DRIVER AM4406/4406F****General Description**

The AM4406/4406F are 2-phase, half-wave motor pre-drivers fabricated for fan motors. These ICs are equipped with lock shutdown and automatic restart functions. The lock shutdown function turns off the output current when the motor is under lock condition. And when the motor is unlocked, the ICs will automatically restart and allow DC fan to run.

In addition, the AM4406 and AM4406F have RD and FG functions respectively. The RD function is to detect the motor status and FG function enables frequency generation.

The AM4406/4406F are available in SOIC-8 package.

Features

- Hall Inputs with a Hysteresis
- Lock Shutdown and Automatic Restart
- Rotation Detection (RD) Output
- Frequency Generation (FG) Output
- Supply Voltage: 4 to 28V
- Output Current: 70mA Max.
- Operating Temperature: -40 to 95°C

Applications

- High Voltage, High Current Brushless DC Fan
- Power Supply and Switchboards
- Communications Facilities
- Industrial Equipment



Figure 1. Package Type of AM4406/4406F

2-PHASE HALF-WAVE HIGH VOLTAGE MOTOR PRE-DRIVER AM4406/4406F

Pin Configuration

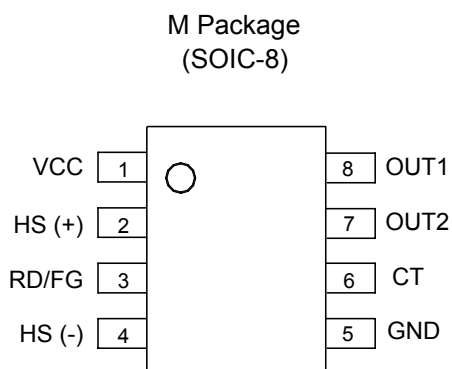

Figure 2. Pin Configuration of AM4406/4406F (Top View)

Pin Description

Pin Number	Pin Name		Function
	AM4406	AM4406F	
1	VCC	VCC	Power supply
2	HS (+)	HS (+)	Hall input (+)
3	RD	FG	Rotation detection/Frequency generation
4	HS (-)	HS (-)	Hall input (-)
5	GND	GND	Ground
6	CT	CT	Timing capacitor
7	OUT2	OUT2	Driver output 2
8	OUT1	OUT1	Driver output 1

2-PHASE HALF-WAVE HIGH VOLTAGE MOTOR PRE-DRIVER AM4406/4406F

Functional Block Diagram

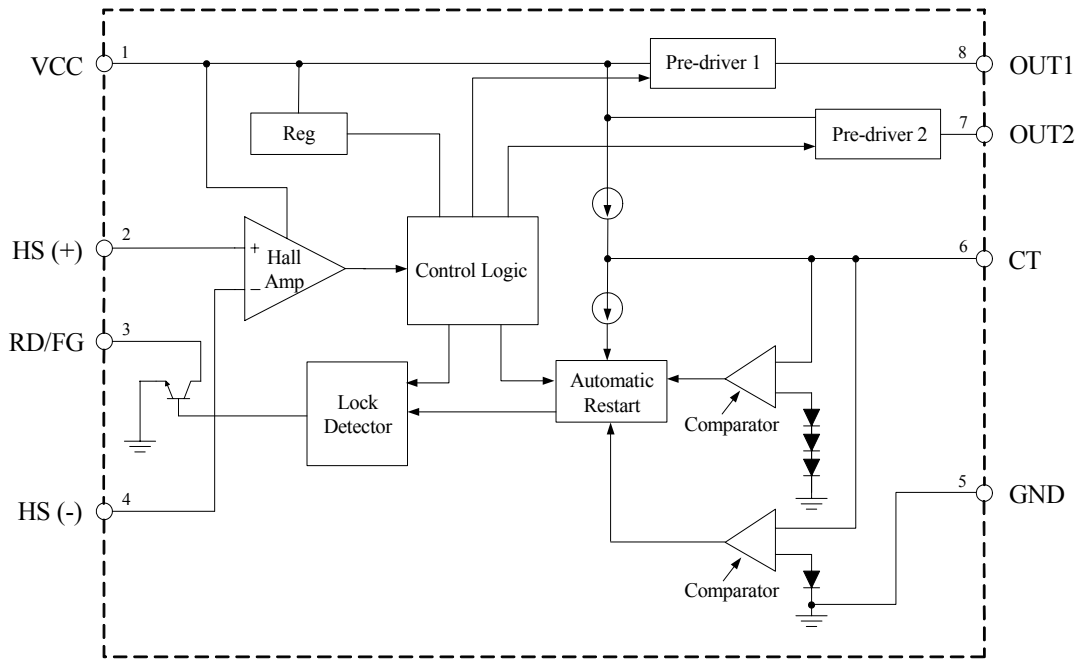
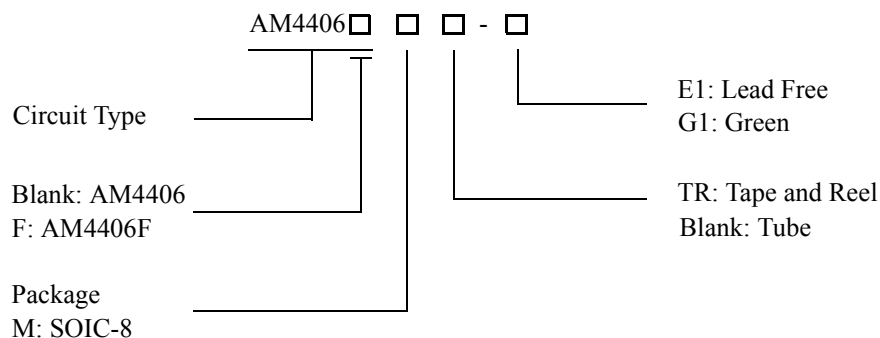

Figure 3. Functional Block Diagram of AM4406/4406F



2-PHASE HALF-WAVE HIGH VOLTAGE MOTOR PRE-DRIVER AM4406/4406F

Ordering Information



Package	Temperature Range	Part Number		Marking ID		Packing Type
		Lead Free	Green	Lead Free	Green	
SOIC-8	-40 to 95°C	AM4406M-E1	AM4406M-G1	AM4406M	AM4406M-G1	Tube
		AM4406MTR-E1	AM4406MTR-G1	AM4406M	AM4406M-G1	Tape & Reel
			AM4406FMTR-G1		AM4406FM-G1	Tape & Reel

BCD Semiconductor's Pb-free products, as designated with "E1" suffix in the part number, are RoHS compliant. Products with "G1" suffix are available in green packages.

**2-PHASE HALF-WAVE HIGH VOLTAGE MOTOR PRE-DRIVER AM4406/4406F****Absolute Maximum Ratings (Note 1)**

Parameter	Symbol	Value	Unit
Supply Voltage	V_{CC}	30	V
Output Current	I_{OUT}	70	mA
Power Dissipation	P_D	550 (Note 2)	mW
Storage Temperature Range	T_{STG}	-55 to 125	°C
ESD (Human Body Model)	ESD	3000	V
ESD (Machine Model)	ESD	300	V

Note 1: Stresses greater than those listed under "Absolute Maximum Ratings" may cause permanent damage to the device. These are stress ratings only, and functional operation of the device at these or any other conditions beyond those indicated under "Recommended Operating Conditions" is not implied. Exposure to "Absolute Maximum Ratings" for extended periods may affect device reliability.

Note 2: Reduced by 5.5mW/°C when T_A is over 25°C.

Recommended Operating Conditions

Parameter	Symbol	Min	Max	Unit
Supply Voltage	V_{CC}	4	28	V
Hall Input Voltage (+) (Note 3)	$V_{HS}(+)$	1.0	$V_{CC}-0.5$	V
Hall Input Voltage (-) (Note 3)	$V_{HS}(-)$	1.0	$V_{CC}-0.5$	V
Operating Temperature	T_A	-40	95	°C

Note 3: Hall input voltage range includes the amplitude of signal.

**2-PHASE HALF-WAVE HIGH VOLTAGE MOTOR PRE-DRIVER AM4406/4406F****Electrical Characteristics**(V_{CC}=12V, T_A=25°C, unless otherwise specified.)

Parameter	Symbol	Conditions	Min	Typ	Max	Unit
Supply Current	I _{CC}	No load		3.2	5.0	mA
Hall Amplifier Input Hysteresis (+)	V _{HYS} (+)	Zero to peak including offset and hysteresis	3		15	mV
Hall Amplifier Input Hysteresis (-)	V _{HYS} (-)	Zero to peak including offset and hysteresis	-3		-15	mV
CT Charge Current	I _{CHG}	V _{CT} =1.5V	2	3.45	5.25	μA
CT Discharge Current	I _{DHG}	V _{CT} =1.5V	0.35	0.8	1.45	μA
CT Charge and Discharge Ratio	R _{CD}	I _{CHG} /I _{DHG}	3	4.5	8	
CT Clamp Voltage	V _{CL}		2.2	2.6	3	V
CT Comparator Voltage	V _{CP}		0.4	0.6	0.8	V
OUT1 High Level Voltage	V _{OH1}	I _{OUT1} =10mA	10	10.5		V
OUT2 High Level Voltage	V _{OH2}	I _{OUT2} =10mA	10	10.5		V
RD Output Low Level Voltage	V _{RDL}	I _{RD} =5mA		0.2	0.5	V
RD Current Capacity	I _{RD}	V _{RD} =2V	8	18		mA
FG Output Low Level Voltage	V _{FGL}	I _{FG} =5mA		0.2	0.5	V
FG Current Capacity	I _{FG}	V _{FG} =2V	8	18		mA



2-PHASE HALF-WAVE HIGH VOLTAGE MOTOR PRE-DRIVER AM4406/4406F

Typical Performance Characteristics

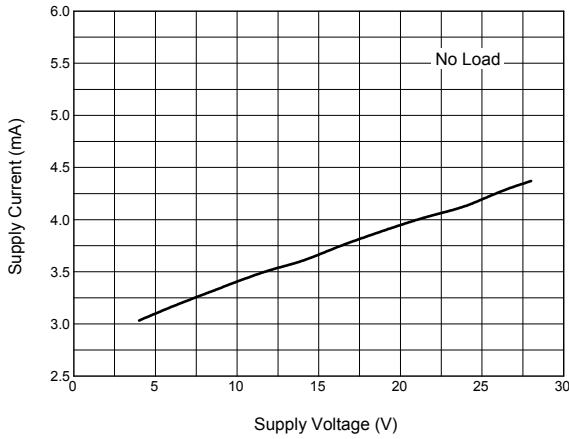

Figure 4. Supply Current vs. Supply Voltage

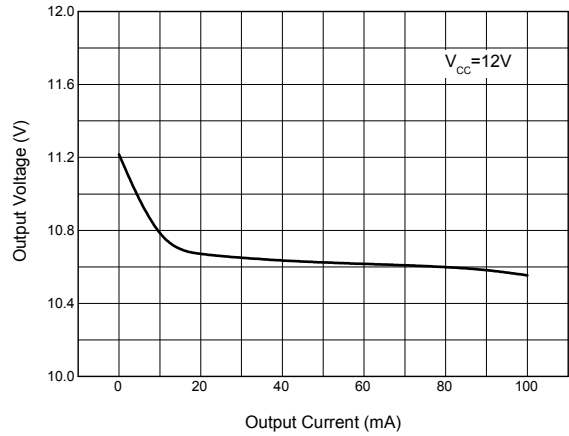

Figure 5. Output Voltage vs. Output Current

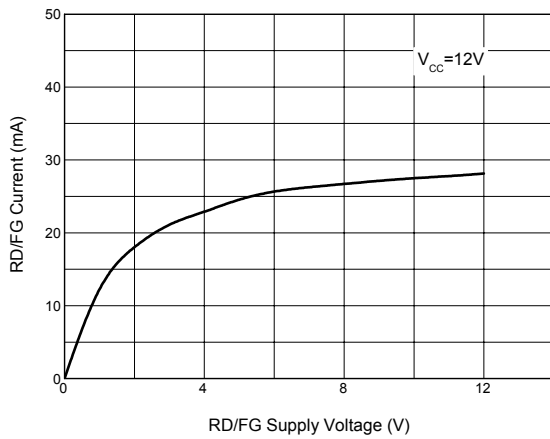

Figure 6. RD/FG Current vs. RD/FG Supply Voltage

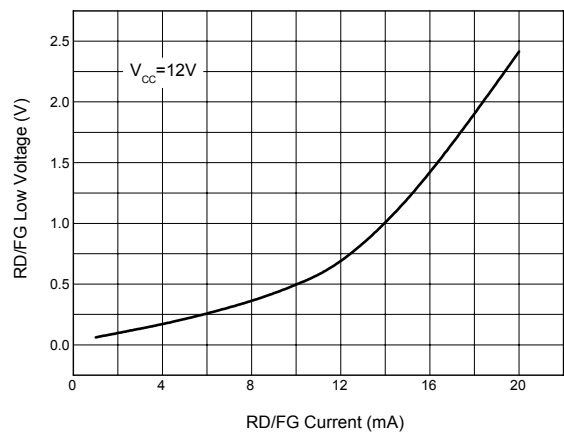

Figure 7. RD/FG Low Voltage vs. RD/FG Current



2-PHASE HALF-WAVE HIGH VOLTAGE MOTOR PRE-DRIVER AM4406/4406F

Typical Performance Characteristics (Continued)

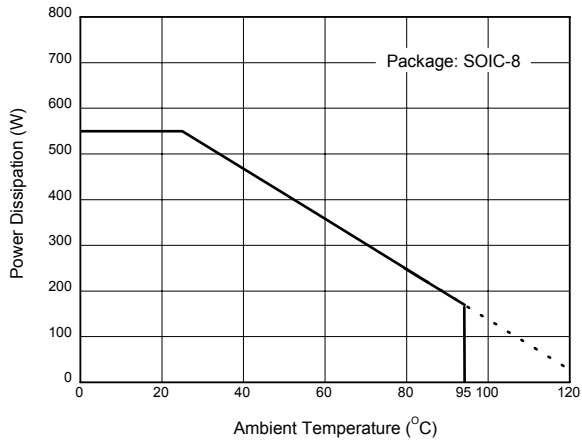
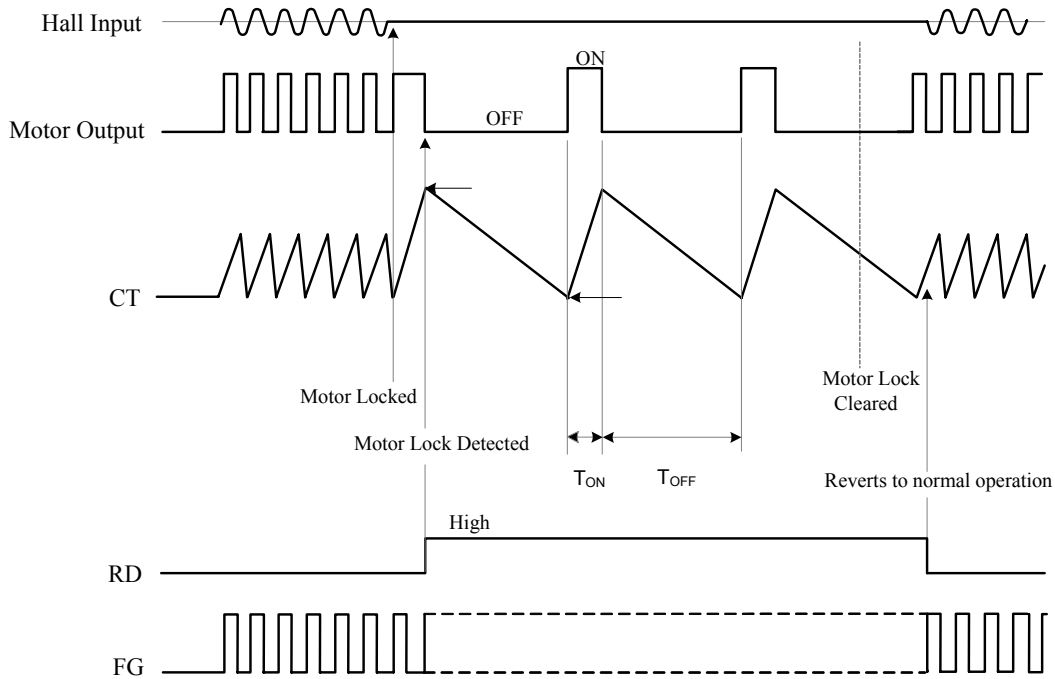

Figure 8. Power Dissipation vs. Ambient Temperature

2-PHASE HALF-WAVE HIGH VOLTAGE MOTOR PRE-DRIVER AM4406/4406F

Operating Diagram



Note 4: Automatic restart is performed in the following manner. A motor lock condition is detected when the hall signal stops switching. The output is ON when CT pin is being charged. C2 is the external capacitor of the CT pin. Output ON time and OFF time are determined by the capacitance of C2.

Note 5: RD pin is ON during normal operation, and OFF when the motor is locked. It is an open collector output pin.

$$T_{ON} = \frac{C2 * (V_{CL} - V_{CP})}{I_{CHG}} (\text{Sec.})$$

$$T_{OFF} = \frac{C2 * (V_{CL} - V_{CP})}{I_{DHG}} (\text{Sec.})$$

Note 6: The RD pin may maintain HIGH level for a few hundred milliseconds when the power is turn on.

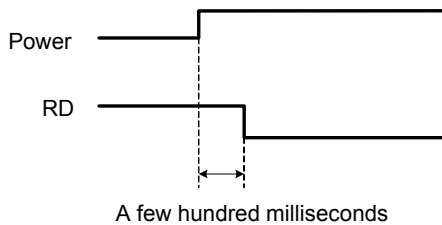
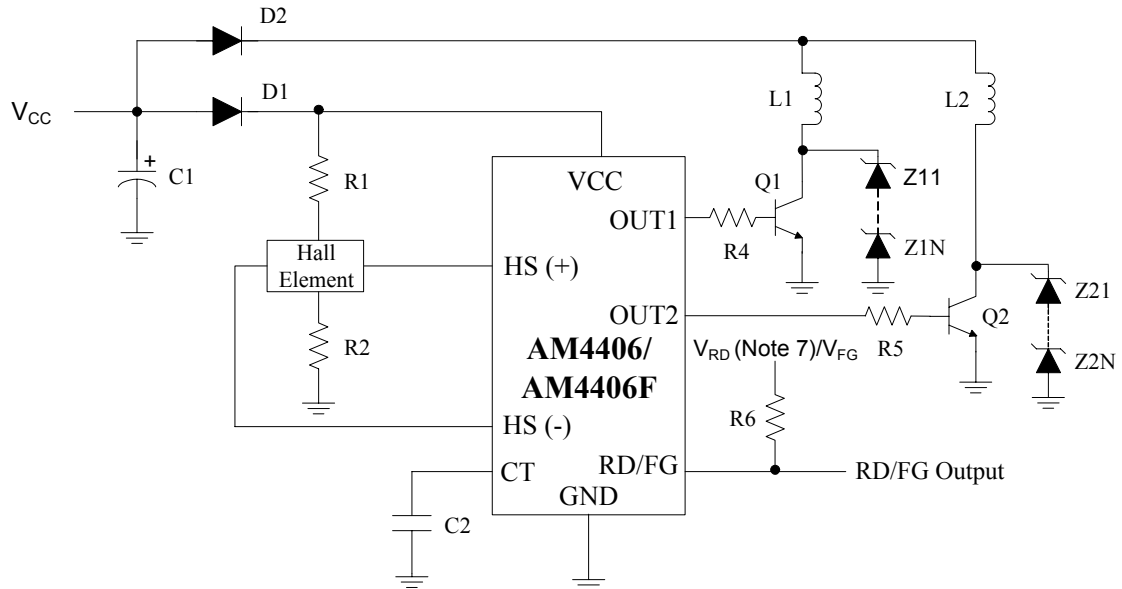

Figure 9. Control Timing Diagram of AM4406/4406F

2-PHASE HALF-WAVE HIGH VOLTAGE MOTOR PRE-DRIVER AM4406/4406F

Typical Application



Note 7: V_{RD} should be equal or smaller than V_{CC} .

Figure 10. Typical Application of AM4406/4406F



2-PHASE HALF-WAVE HIGH VOLTAGE MOTOR PRE-DRIVER AM4406/4406F

Mechanical Dimensions

SOIC-8

Unit: mm(inch)

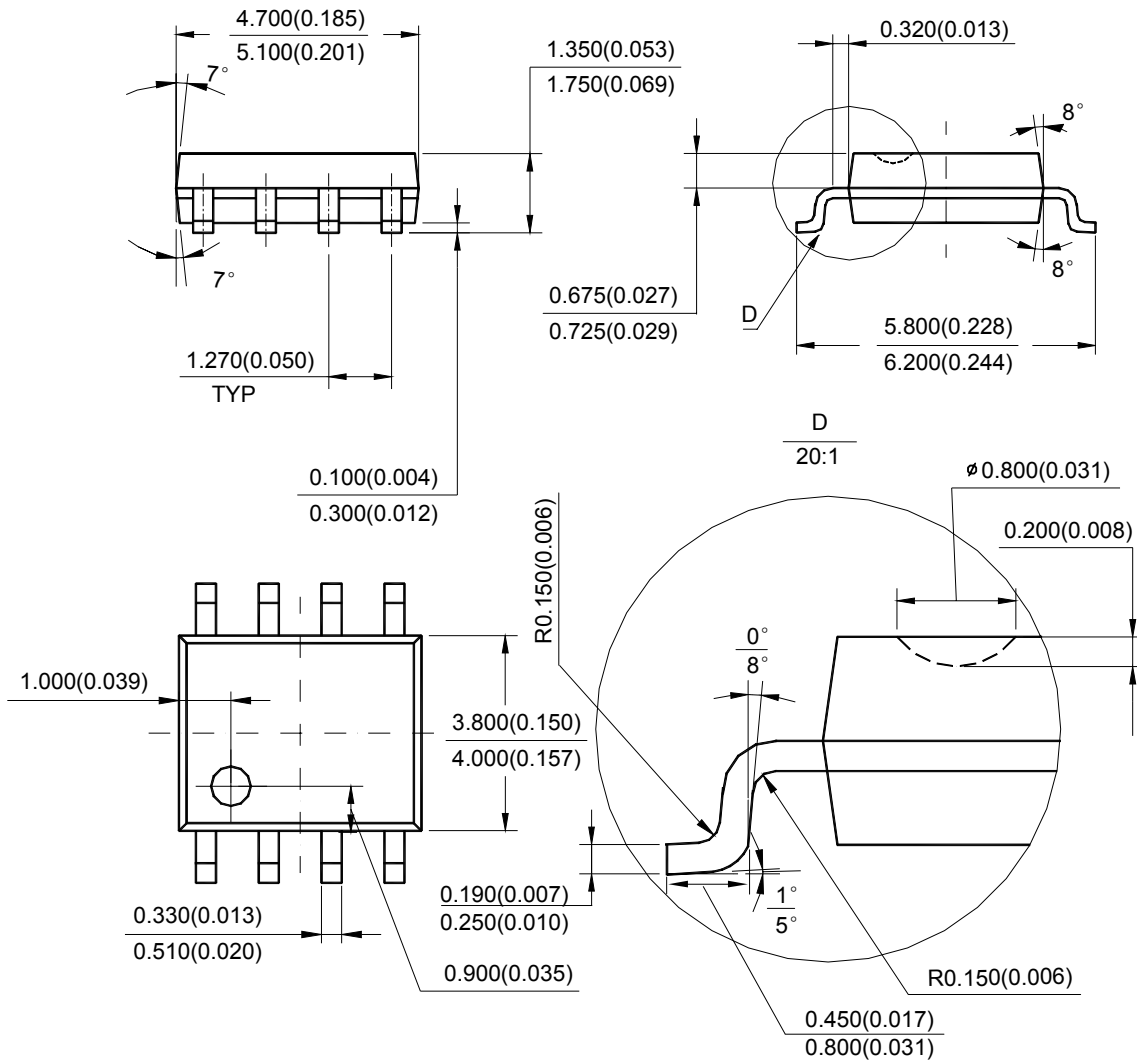

Note: Eject hole, oriented hole and mold mark is optional.



BCD Semiconductor Manufacturing Limited

<http://www.bcdsemi.com>

IMPORTANT NOTICE

BCD Semiconductor Manufacturing Limited reserves the right to make changes without further notice to any products or specifications herein. BCD Semiconductor Manufacturing Limited does not assume any responsibility for use of any its products for any particular purpose, nor does BCD Semiconductor Manufacturing Limited assume any liability arising out of the application or use of any its products or circuits. BCD Semiconductor Manufacturing Limited does not convey any license under its patent rights or other rights nor the rights of others.

MAIN SITE

- Headquarters

BCD (Shanghai) Micro-electronics Limited

No. 1600, Zi Xing Road, Shanghai ZiZhu Science-based Industrial Park, 200241, P. R. C.
Tel: +86-021-2416-2266, Fax: +86-021-2416-2277

- Wafer Fab

Shanghai SIM-BCD Semiconductor Manufacturing Co., Ltd.

800 Yishan Road, Shanghai 200233, China
Tel: +021-6485-1491, Fax: +86-021-5450-0008

REGIONAL SALES OFFICE

Shenzhen Office

Shanghai SIM-BCD Semiconductor Manufacturing Co., Ltd., Shenzhen Office

Unit A Room 1203, Skyworth Bldg., Gaoxin Ave.1.S., Nanshan District
Shenzhen 518057, China

Tel: +86-0755-8660-4900, Fax: +86-0755-8660-4958

Taiwan Office (Taipei)

BCD Semiconductor (Taiwan) Company Limited

3F, No.17, Lane 171, Sec. 2, Jiu-Zong Rd., Nei-Hu Dist., Taipei(114), Taiwan, R.O.C
Tel: +886-2-2656-2808

Fax: +886-2-2656-2806/26562950

Taiwan Office (Hsinchu)

BCD Semiconductor (Taiwan) Company Limited

8F, No.176, Sec. 2, Gong-Dao 5th Road, East District
HsinChu City 300, Taiwan, R.O.C

Tel: +886-3-5160181, Fax: +886-3-5160181

USA Office

BCD Semiconductor Corp.

48460 Kato Road, Fremont, CA 94538, USA
Tel: +1-510-668-1950

Fax: +1-510-668-1990

Korea Office

BCD Semiconductor Limited Korea office.

Room 101-1112, Digital-Empire II, 486 Sin-dong,
Yeongtong-Gu, Suwon-city, Gyeonggi-do, Korea

Tel: +82-31-695-8430