

Jul.1.2019 Copyright 2019 HIROSE ELECTRIC CO., LTD. All Rights Reserved.  
 In case of consideration for using Automotive equipment / device which demand high reliability, kindly contact our sales window correspondents.

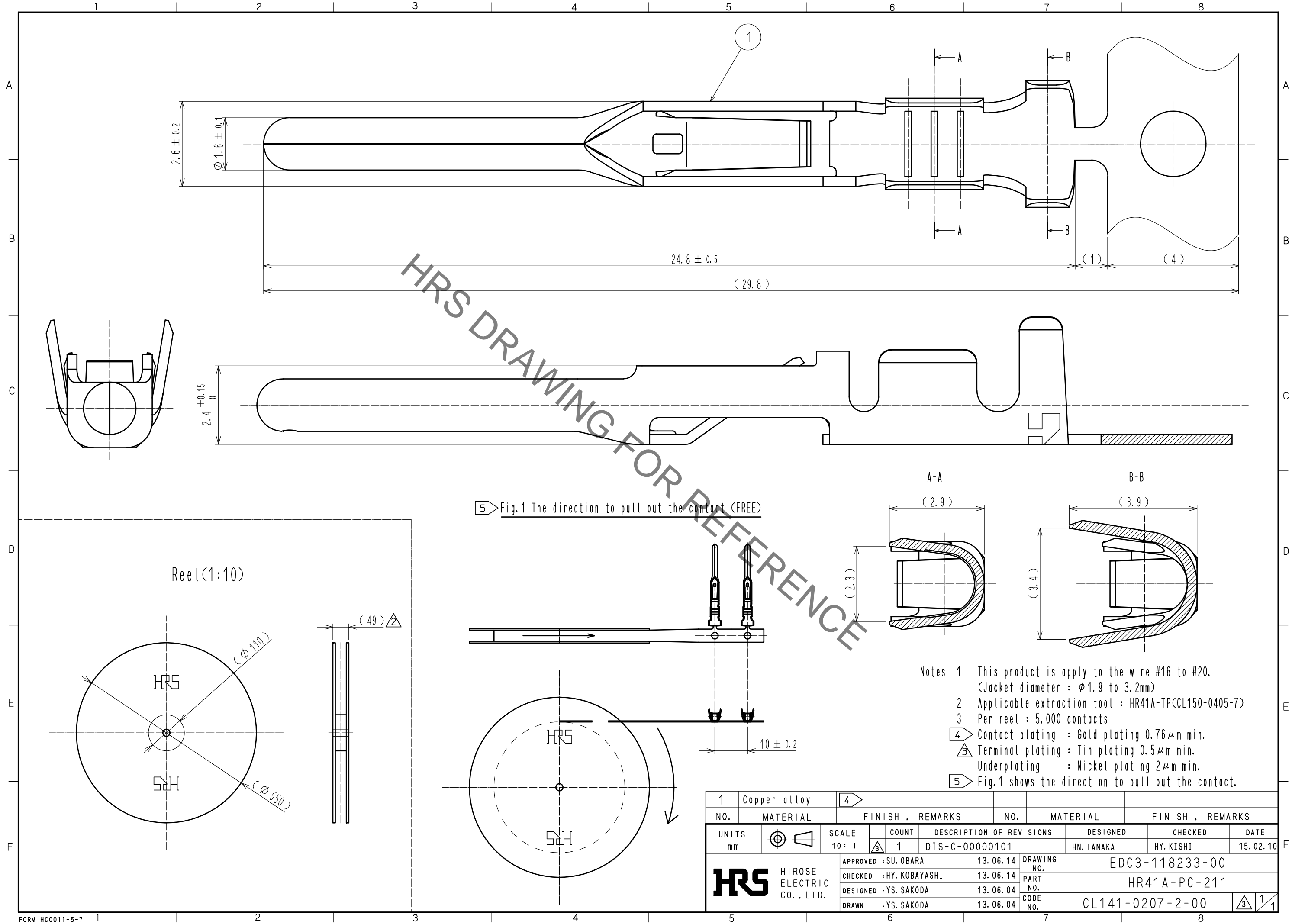

5 Fig.1 The direction to pull out the contact (FREE)

- Notes
- This product is apply to the wire #16 to #20. (Jacket diameter :  $\phi 1.9$  to  $3.2$ mm)
  - Applicable extraction tool : HR41A-TP(CL150-0405-7)
  - Per reel : 5,000 contacts
  - Contact plating : Gold plating  $0.76 \mu\text{m}$  min.
  - Terminal plating : Tin plating  $0.5 \mu\text{m}$  min. Underplating : Nickel plating  $2 \mu\text{m}$  min.
  - Fig.1 shows the direction to pull out the contact.

1	Copper alloy	4							
NO.	MATERIAL	FINISH	REMARKS	NO.	MATERIAL	FINISH	REMARKS		
UNITS	$\phi$	SCALE	COUNT	DESCRIPTION OF REVISIONS			DESIGNED	CHECKED	DATE
mm		10:1	1	DIS-C-00000101			HN. TANAKA	HY. KISHI	15.02.10
APPROVED : SU. OBARA				13.06.14		DRAWING NO. EDC3-118233-00			
CHECKED : HY. KOBAYASHI				13.06.14		PART NO. HR41A-PC-211			
DESIGNED : YS. SAKODA				13.06.04		CODE NO. CL141-0207-2-00			
DRAWN : YS. SAKODA				13.06.04		1/1			