

NOTES:

1. MATERIALS AND FINISHES:

- BODY, REAR BODY - BRASS, NICKEL PLATING
- CONTACT - BRASS, GOLD PLATING
- INSULATOR - PTFE
- INSULATOR REAR - ULTEM
- HEX NUT - BRASS, NICKEL PLATING
- LOCK WASHER - BRASS, NICKEL PLATING
- CAP - BRASS, NICKEL PLATING
- GASKET, O-RING - SILICONE RUBBER
- FERRULE - SEAMLESS COPPER TUBE, NICKEL PLATING
- HEAT SHRINK TUBING - CROSSLINKED POLYOLEFIN

2. ELECTRICAL:

- A. IMPEDANCE: 50 OHM
- B. FREQUENCY RANGE: DC - 6 GHz
- C. DIELECTRIC WITHSTANDING VOLTAGE: 1000 VRMS, MIN.

3. MECHANICAL:

- A. DURABILITY: 500 CYCLES MIN.
- B. TEMPERATURE RANGE: -40° C TO +85° C

4. PACKAGING:

- A. QUANTITY: SINGLE PACK
- B. MARKING: MARK BAG OR TAG "AMPHENOL RF, 31-6510, AND DATE CODE"

5. RECOMMENDED CABLE ASSEMBLY INSTRUCTIONS:

- A. TRIM CABLE AS SHOWN.
- B. SLIDE HEAT SHRINK TUBING, FERRULE AND INSULATOR REAR ONTO CABLE.
- C. INSERT CABLE WITH FOIL ENTERING CONNECTOR AND BRAID OVER KNURL.
- D. SOLDER CABLE CENTER CONDUCTOR TO CONTACT.
- E. CRIMP FERRULE OVER BRAID WITH 0.213" HEX DIE.
- F. APPLY HEAT SHRINK TUBING OVER FERRULE.
- G. HEAT SHRINK TUBING SHOULD FULLY (360 DEG) COVER THE BUMP ON BODY AND END WITHIN AREA "A"

6. CAP ASSEMBLY INSTRUCTIONS:

- A. PLACE O-RING ON CAP AS SHOWN.
- B. ASSEMBLE CAP TO BODY WITH 6-10 IN-LBS TORQUE.

7. RECOMMENDED TORQUE APPLIED ON HEX NUT: 7-10 IN-LBS.

8. SHOWS CABLE ENTRY DIMENSIONS.

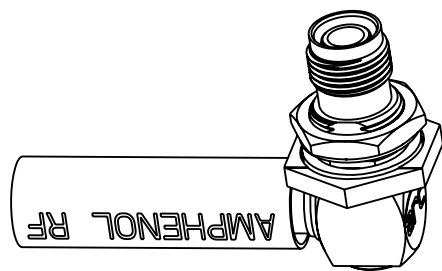

SCALE 1.000

THIRD ANGLE PROJ.

REVISIONS

REV	DESCRIPTION	DATE	ECO	APPR
A	RELEASE TO MFG.	25-Mar-13	48952	TD
B	ADDED ARC LOGO TO REAR BODY & AMPHENOL RF TO HST \RD-DMI3082201J8	30-Aug-13	49619	RLB

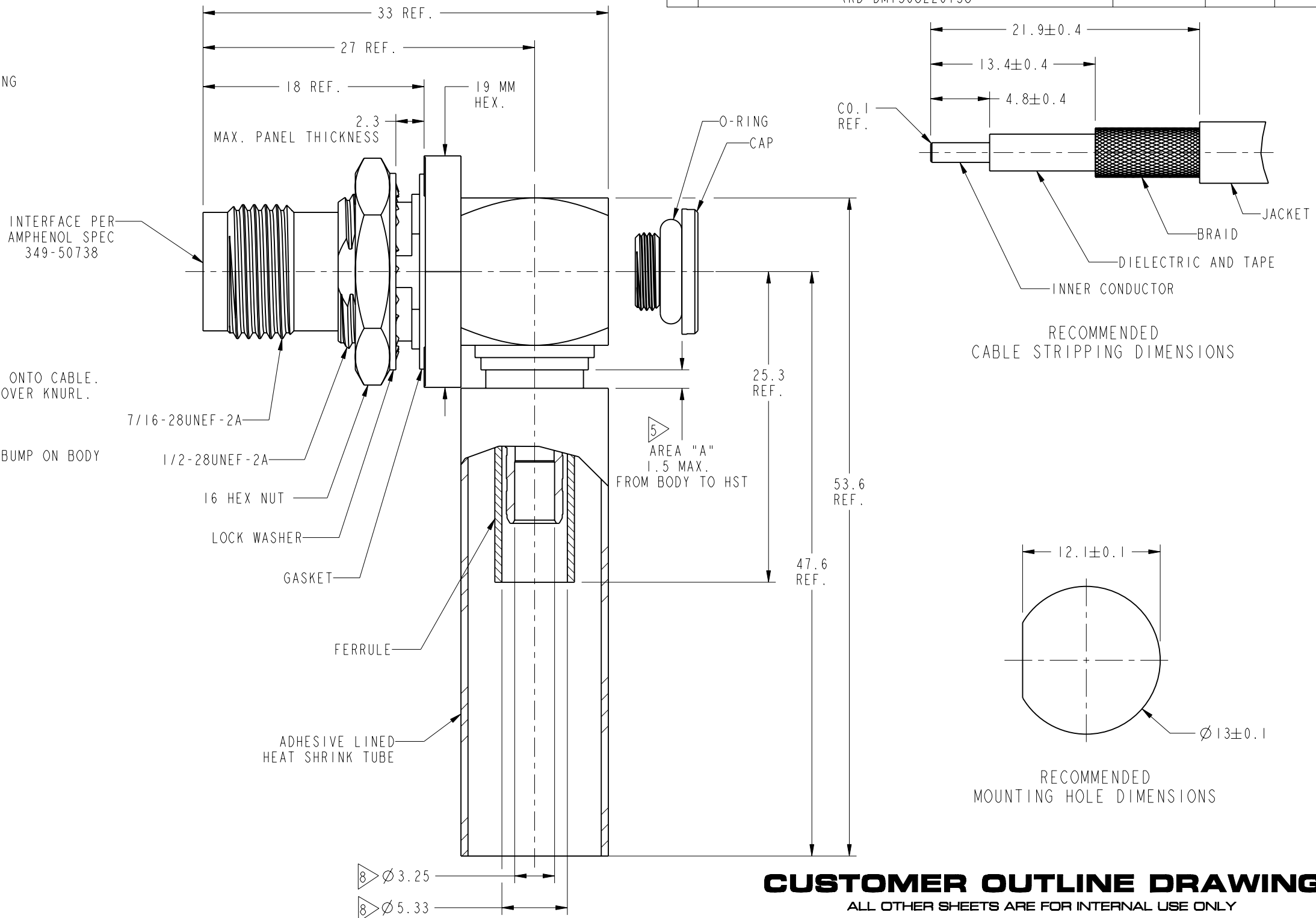

CUSTOMER OUTLINE DRAWING
ALL OTHER SHEETS ARE FOR INTERNAL USE ONLY

UNLESS OTHERWISE SPECIFIED, DIMENSIONS ARE IN METRIC AND TOLERANCES ARE:
 <0.5mm ±0.05mm 0.5 - 6mm ±0.1mm 6 - 30mm ±0.2mm 30 - 120mm ±0.3mm ANGLES ±1°

NOTICE - These drawings, specifications, or other data (1) are, and remain the property of Amphenol corp. (2) must be returned upon request; and (3) are confidential and not to be disclosed to any person other than those to whom they are given by Amphenol Corp. the finishing of these drawings, specifications, or other data by Amphenol Corp., or to any other person to anyone for any purpose is not to be regarded by implication or otherwise in any manner licensing, granting rights to permitting such holder or any other person to manufacture, use or sell any product, process or design, patented or otherwise, that may in any way be related to or disclosed by said drawings, specifications, or other data.

MATERIAL	SEE NOTES	DRAWN	J.CHEN	DATE	30-Aug-13	TITLE TNC R/A RP BHD JACK 1P-67 FOR LMR 200 CABLE		Amphenol RF www.amphenolrf.com	
REFERENCE		ENGINEER	BALAJI M	DATE	22-Mar-13				
CONFIGURATION LEVEL:		APPROVED	S.HSIEH	DATE	04-Sep-13	SCALE: 2.7:1.0	SHEET 2 OF 2	DRAWING NO. 31-6510	
FINISH		CAD FILE				DWG SIZE B	REV B	ITEM NO. 31-6510	
								PART NO. 31-6510	