

REV
E
WHDS-18-2

REVISIONS			
SYM	DESCRIPTION	DATE	APPROVED
B	REVISED PER E.O. 93864	2/16/83	T.H.
C	REVISED PER E.O. P15473	11/20/90	R.D.R.
D	REVISED PER E.O. P18579	6/14/04	R.D.R.
E	REVISED PER E.O. P19027	8-31-05	ADR

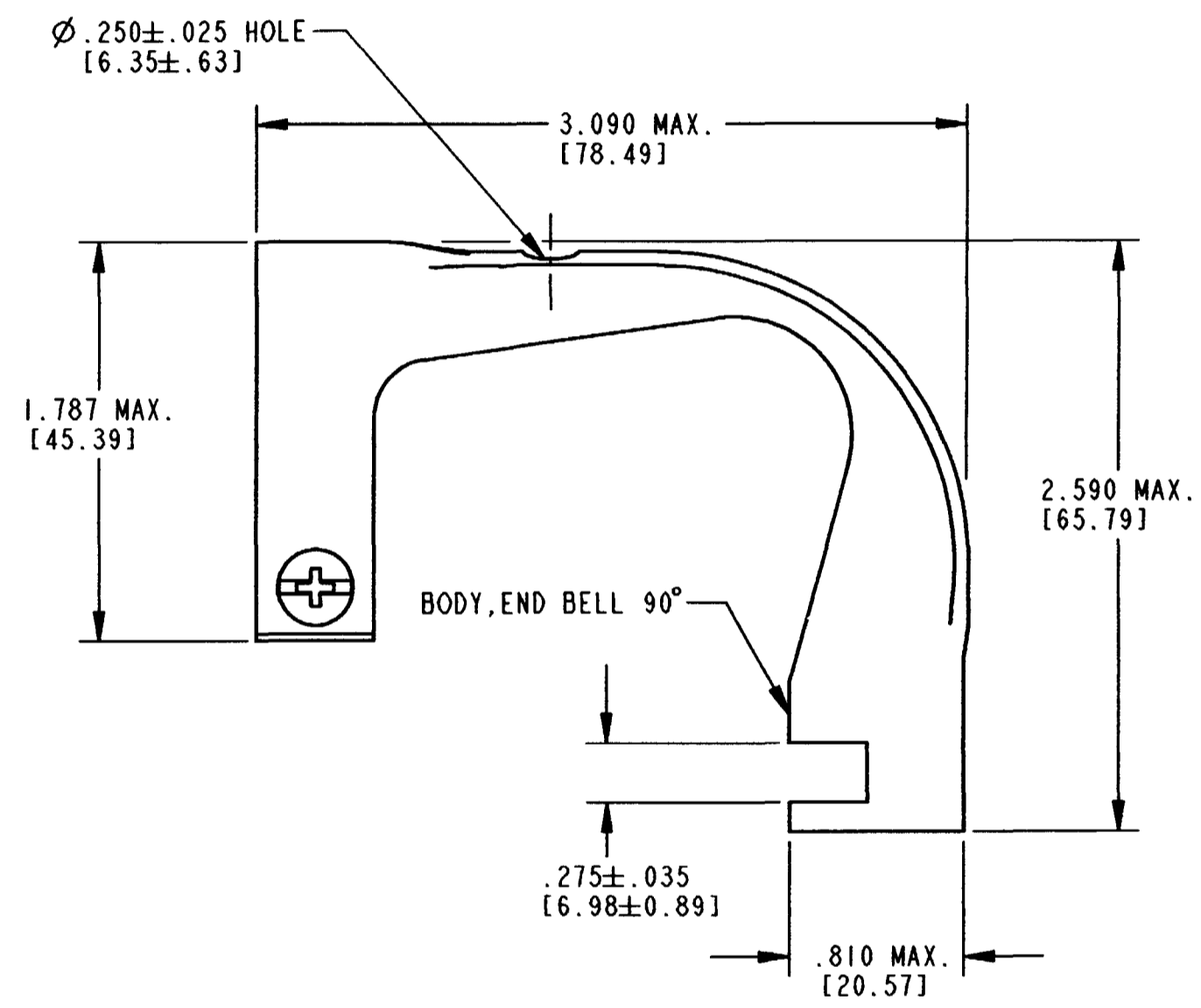
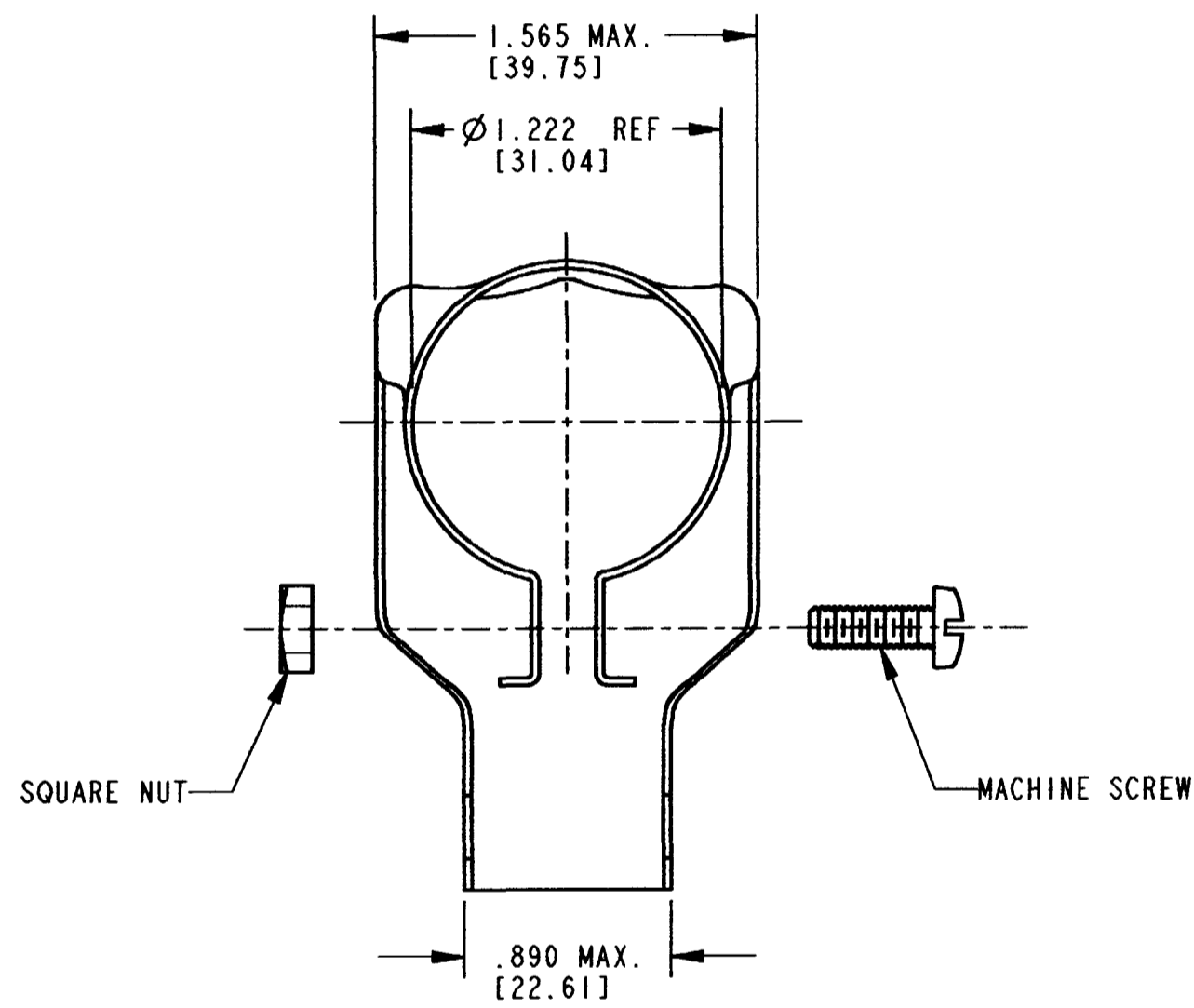

- 5. MACHINE SCREW TORQUE RANGE: 7-10 IN LBS [0.79-1.13 NM].
- 4. MATERIAL: STEEL.
- 3. FINISH: TIN OVER NICKEL PLATE.
- 2. PARTS SHIPPED UNASSEMBLED.

NOTES: 1. DIMENSIONS ARE IN INCHES [MILLIMETERS] UNLESS OTHERWISE SPECIFIED.

SIGNATURE & DATE		END BELL 90° HD SERIES	CP	MATL. CODE
DR	X. SANCHEZ 19MAY04		The Deutch Company DEUTSCH I.P.D. 3850 INDUSTRIAL AVE. HEMET, CALIF. 92545	
CHK	<i>[Signature]</i>		B WHDS-18-2 DWG SIZE CODE SHEET OF 11139	
PE	<i>[Signature]</i>			
APPD	<i>[Signature]</i>	ENVELOPE		
SCALE	NONE	WT		