

ASSEMBLY PART NUMBER CHART

PART NUMBERS				KEY OPTION	COLOR	COMPONENTS			
DELPHI	REV	MVL	REV			INSULATOR (HOUSING)	TPA (BLUE)	RING SEAL (GREEN)	CPA (RED) (OPTIONAL)
						ITEM 1	ITEM 2	ITEM 3	ITEM 4
13806231	01	F495100	A	A	BLACK	S106100	S506100		
13848932	01	F595100	A	B	LT GRAY	S206100	S606100		N/A
15532568	01	F695100	A	C	DK GRAY	S306100	S706100		
13973607	02	F460400	B	A	BLACK	S106100	S506100	C895100	
33511726	02	F560400	B	B	LT GRAY	S206100	S606100		F752210
33511727	02	F660400	B	C	DK GRAY	S306100	S706100		

APPLICABLE COMPONENTS CHART

ITEM NO.	DESCRIPTION	PLATING OR COLOR	SUPPLIER NUMBER		DELPHI NUMBER	GRIP CODE	WIRE SIZE	INSULATION DIAMETER RANGE	MATERIAL/SPEC NO
			NAME	NUMBER					
5	1.20 SYSTEM TERMINAL	TIN	MVL	54001864	13576990	18	18-16 AWG 0.75-1.25mm <sup>2</sup>	1.70mm-2.41mm	COPPER ALLOY / NA
	1.20 SYSTEM TERMINAL	TIN	MVL	54002006	13806233	20	22-20 AWG 0.35-0.50mm <sup>2</sup>	1.20mm-1.90mm	COPPER ALLOY / NA
	1.20 SYSTEM TERMINAL	TIN/SILVER	MVL	54001866	13587331	18	18-16 AWG 0.75-1.25mm <sup>2</sup>	1.70mm-2.41mm	COPPER ALLOY / NA
	1.20 SYSTEM TERMINAL	TIN/SILVER	MVL	54002007	15521522	20	22-20 AWG 0.35-0.50mm <sup>2</sup>	1.20mm-1.90mm	COPPER ALLOY / NA
	1.20 SYSTEM TERMINAL	SILVER	MVL	F731400	13805376	18	18-16 AWG 0.75-1.25mm <sup>2</sup>	1.70mm-2.41mm	COPPER ALLOY / NA
	1.20 SYSTEM TERMINAL	SILVER	MVL	F931400	13805375	20	22-20 AWG 0.35-0.50mm <sup>2</sup>	1.20mm-1.90mm	COPPER ALLOY / NA
	1.20 SYSTEM TERMINAL	GOLD	MVL	54001863	13579640	18	18-16 AWG 0.75-1.25mm <sup>2</sup>	1.70mm-2.41mm	COPPER ALLOY / NA
	1.20 SYSTEM TERMINAL	GOLD	MVL	54002005	13827658	20	22-20 AWG 0.35-0.50mm <sup>2</sup>	1.20mm-1.90mm	COPPER ALLOY / NA
	1.20 SYSTEM CABLE SEAL ROUND	RUST RED	MVL (QSR)	C528010 (A-0419)	13898958		18-16 AWG 1.00-1.25mm <sup>2</sup>	1.90mm-2.41mm	SILICONE
	1.20 SYSTEM CABLE SEAL ROUND	GREEN	MVL (QSR)	(A-0419C)	33402838		22-20 AWG 0.50-0.75mm <sup>2</sup>	1.40mm-1.90mm	SILICONE
1.20 SYSTEM CABLE SEAL ROUND	TAN	MVL (QSR)	C073510 (A-0419B)	33511987		0.35mm <sup>2</sup>	1.20mm-1.40mm	SILICONE	
7	1.20 SYSTEM SEAL PLUG	GREEN	MVL (QSR)	C628010 (A-0412)	13898957		OPTIONAL AS REQUIRED		SILICONE

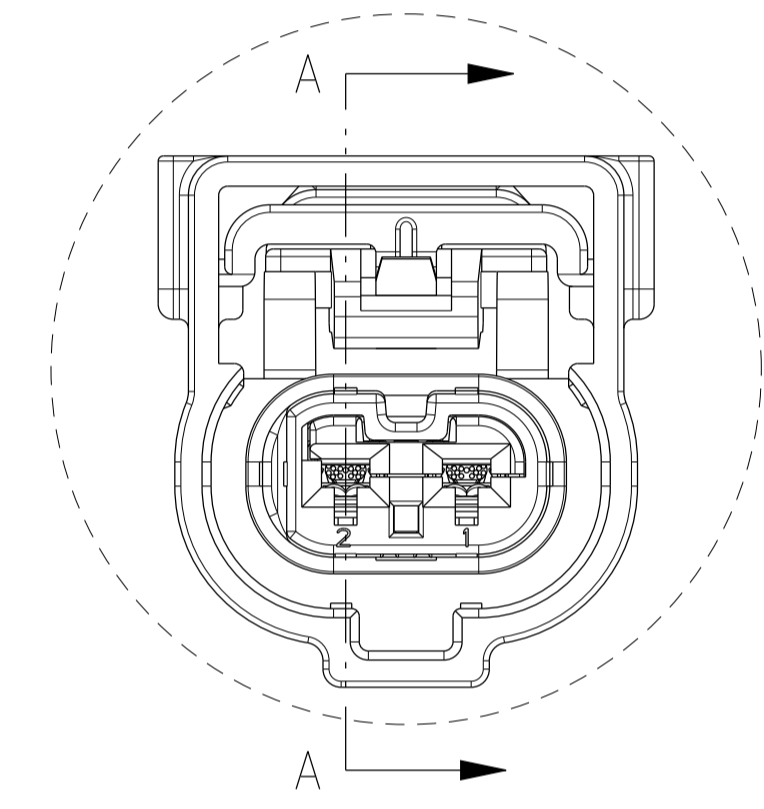
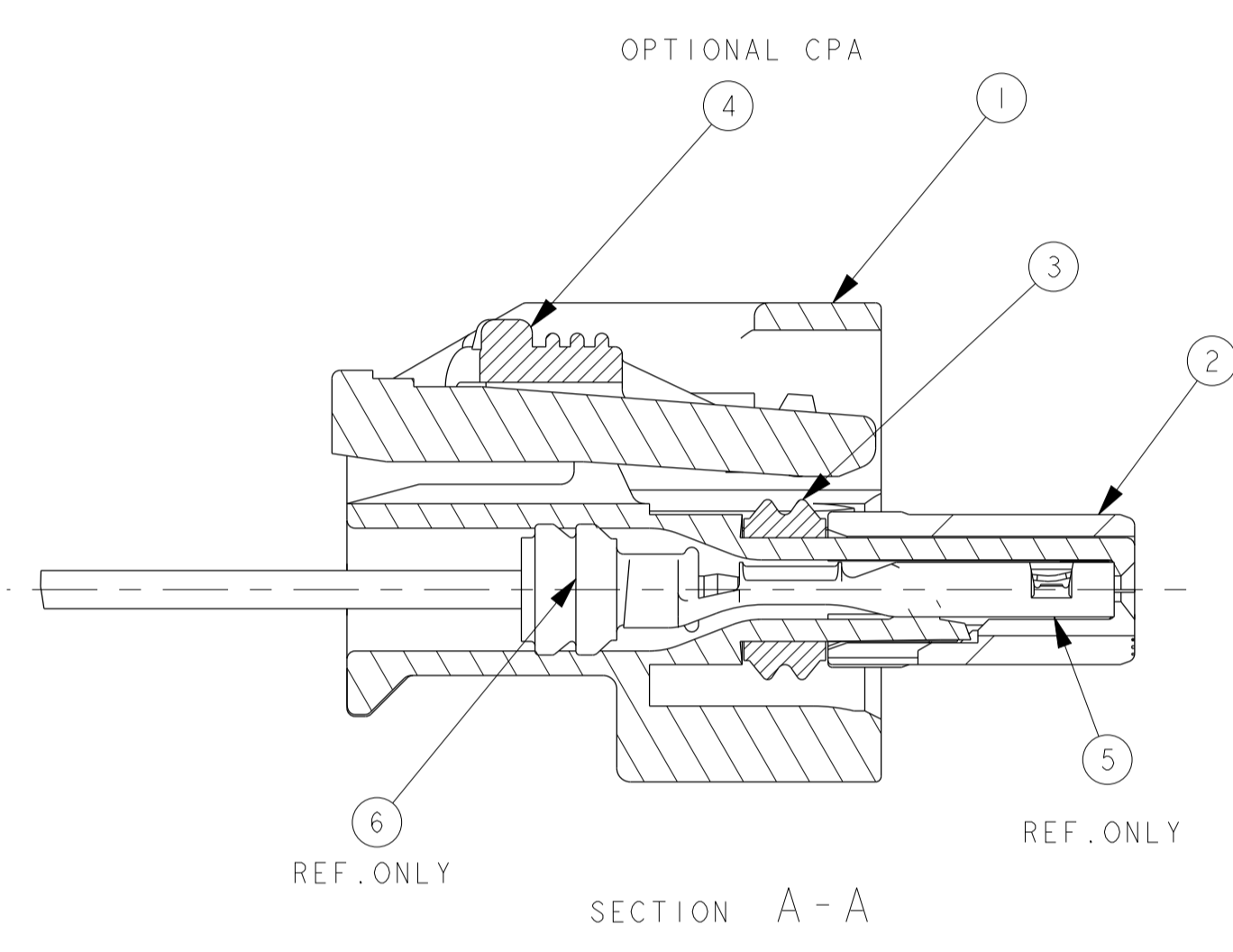
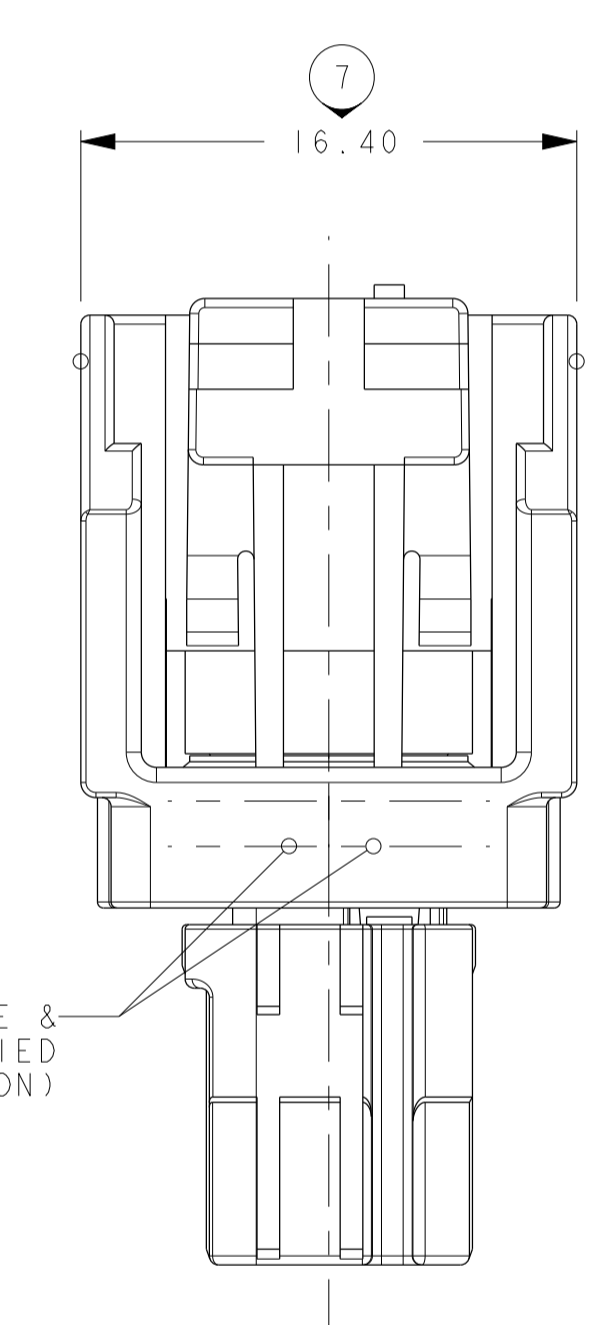
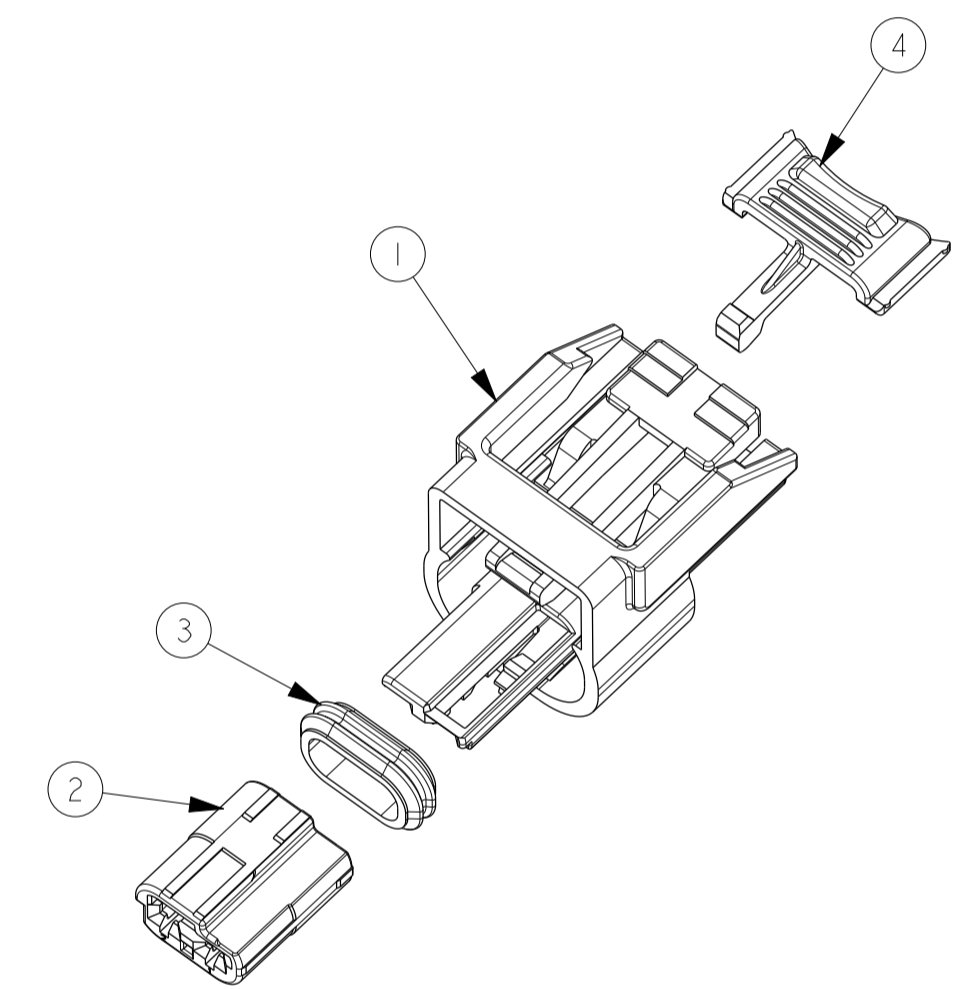
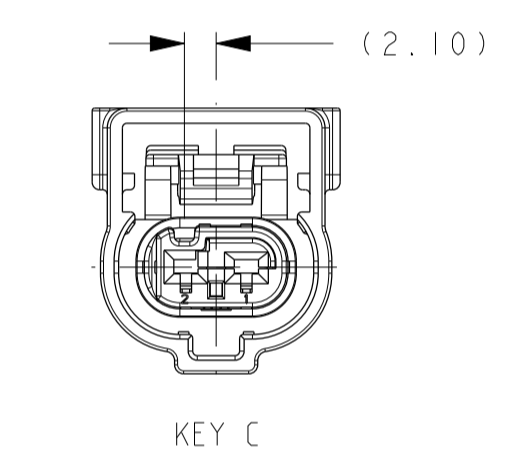
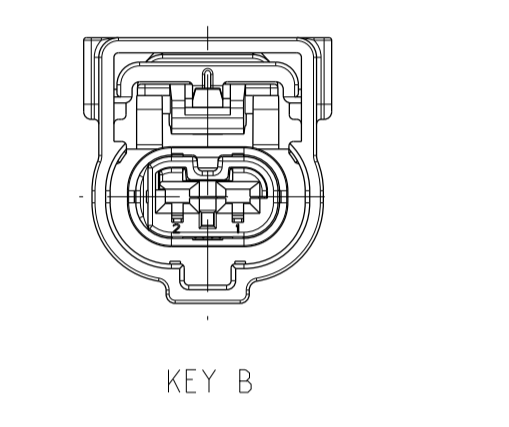
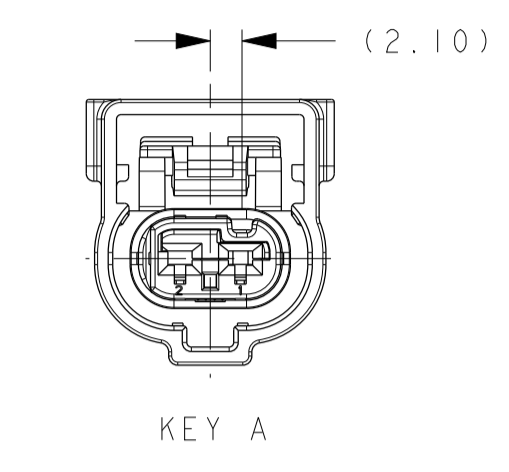
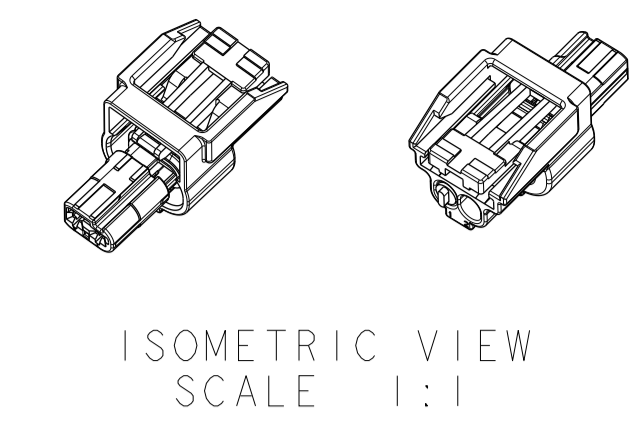

(ASSEMBLY DATE CODE & PART NUMBER APPLIED IN THIS LOCATION)

NOTES:

- VALIDATED TO SAE/USCAR-2 REV 5
  - VALIDATED TO THE FOLLOWING TEMP, VIBRATION, AND SEALING CLASSES:
    - GMW3191 SECTION 4.28 V4 T4 (155°C) WITH GOLD OR SILVER TERMINALS
    - SAE/USCAR-2 V3 T4 (150°C) WITH GOLD OR SILVER TERMINALS
    - SAE/USCAR-2 V3 T3 (125°C) / V2 T4 (150°C) WITH TIN/SILVER TERMINALS
    - SAE/USCAR-2 V2 T3 (125°C) WITH TIN TERMINALS
    - SAE/USCAR-2 SEALING S3 T4 (150°C) (ISO16750 9K EQUIVALENT)
  - CONNECTOR MAY BE USED WITH THE FOLLOWING TERMINALS:
    - DELPHI APEX 1.2 TERMINALS LISTED IN THE APPLICABLE COMPONENTS CHART ON THIS DRAWING WITH WIRE SIZES DEFINED IN NOTE 4.
    - SEE DELPHI DRAWING C18001-1-2-CUST FOR SPECIFIC TERMINAL DETAILS AND CRIMPING REQUIREMENTS
    - PLATING OF TERMINALS AND MATING DEVICE BLADES MUST BE COMPATIBLE
  - CONNECTOR SYSTEM VALIDATED TO USCAR-2 REQUIREMENTS WITH THE FOLLOWING RANGE OF WIRE SIZES AND TYPES IN CONJUNCTION WITH APPROPRIATE COMPONENTS FOUND IN THE "APPLICABLE COMPONENTS" CHART:
    - AWG - WIRE SIZES: 22AWG - 16AWG  
INSULATION DIAMETER: 1.50mm MIN - 2.41mm MAX  
WIRE TYPE: MIL123-A, MS-8288, MS-9502 OR EQUIVALENT (STRUCTURE AND PROPERTIES ACCORDING TO SAE J1128)
    - METRIC - WIRE SIZES: 0.35mm<sup>2</sup> - 1.25mm<sup>2</sup>  
INSULATION DIAMETER: 1.20mm MIN - 2.30mm MAX  
WIRE TYPE: FLR2X, FLR9X OR EQUIVALENT (STRUCTURE AND PROPERTIES ACCORDING TO ISO 6722)
- CONTACT DELPHI ENGINEERING REGARDING USE OF OTHER WIRE SIZES AND/OR TYPES
- WIRE AND INSULATION TYPE MUST BE APPROPRIATE FOR TEMPERATURE CLASS & APPLICATION ENVIRONMENT
- CONNECTOR IS MATE COMPATIBLE WITH DEVICES WHICH CONFORM WITH THE FOLLOWING USCAR INTERFACE SPECIFICATIONS:
    - 120-S-002-1-Z01 (WITH EWCAP-001 TYPE 120-T BLADES)
    - 120-S-002-1-Z02 (WITH EWCAP-001 TYPE 120-T BLADES)
  - ANNUAL QUALITY REQUIREMENTS:
    - IT IS PERMISSIBLE TO PERFORM CONTINUOUS CONFORMANCE PER DELPHI SPECIFICATION #AQA-001 INSTEAD OF ANNUAL LAYOUT AND ANNUAL PV REQUIREMENTS OF ISO TS16949 AND SAE/USCAR-2 REV 5. FOR TERMINAL TO CONNECTOR AND TPA TO CONNECTOR ONLY.
  - SOURCE ID, MOLD & CAVITY ID SIGNIFIES TOOL OWNERSHIP, FOR REFERENCE
  - (K) INDICATES IN-PROCESS INSPECTION FOR MANUFACTURING DIMENSIONS OR SPECIFICATIONS.

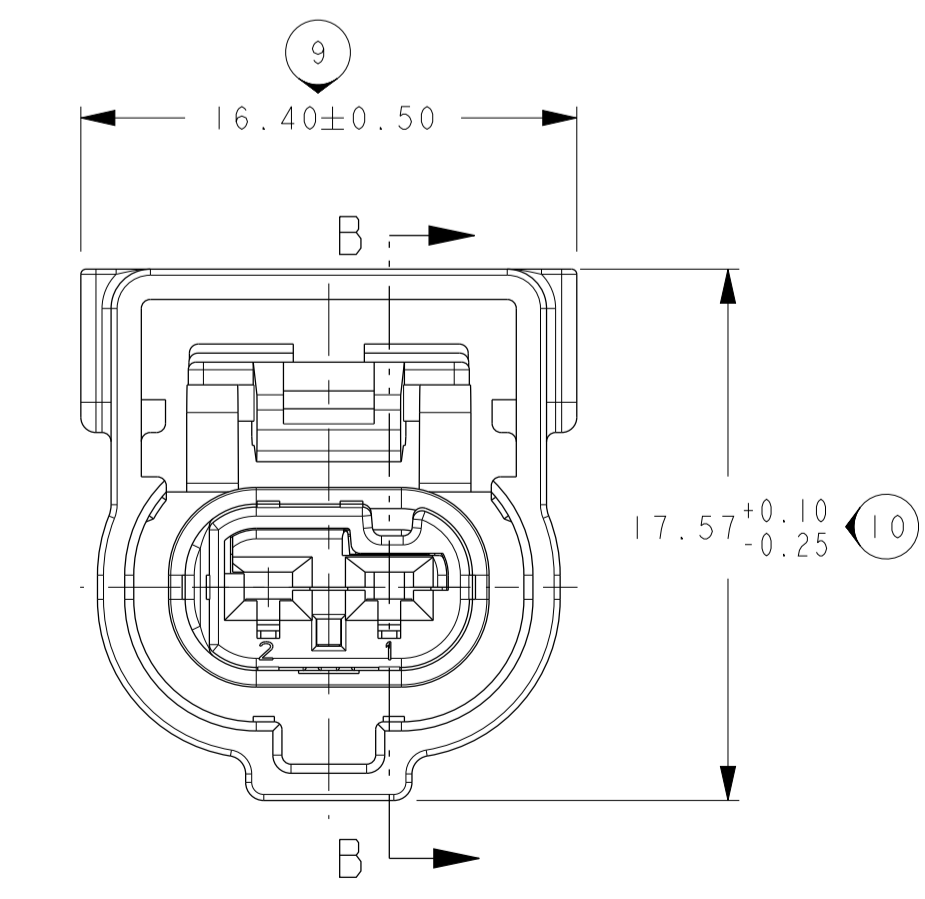
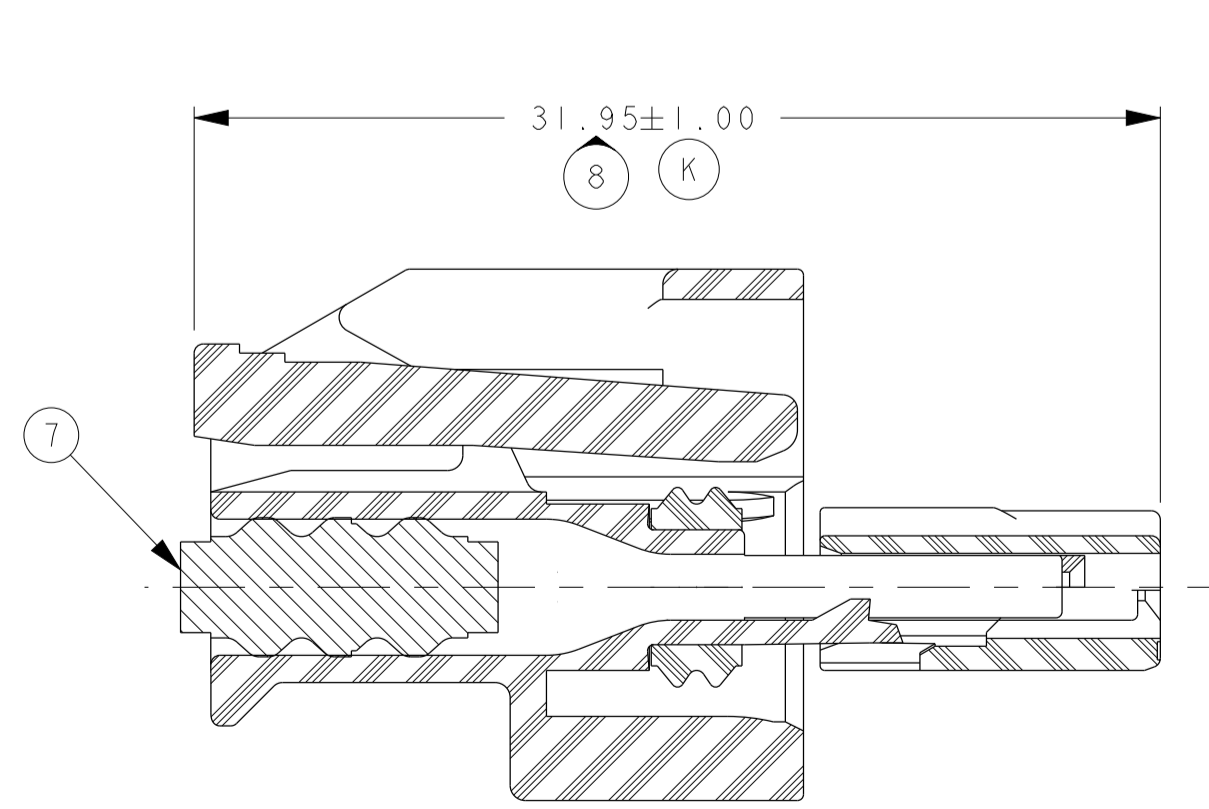

ECN-13-01299	APP	CHRT	ADDED GREEN CABLE SEAL 33402838, REMOVED BLUE CABLE SEAL 54200391/13576991
ECN-13-01227	-	-	ECO 423850 - UPDATE VIEWS FOR DESIGN IMPROVEMENT TO CPA F752210, DELPHI P/N'S ADDED FOR MVL P/N'S, REVISED NOTE 2 - UPDATE PERFORMANCE DATA FOR TIN/SILVER PLATING
ECN-12-01302	-	-	UPDATE CPA IN ASSY VIEWS
	PART BOM		F695100 COLOR WAS BROWN, F660400 COLOR WAS BROWN
ECN-12-01227	APP	CHRT	ADD PART NUMBER C073510, ADD 0.35MM & 22GA WIRE INFO
	NOTES		REVISE NOTE 4 WITH 0.35MM & 22GA INFO
ECN-12-00892	-	-	NEW RELEASE
ECN-NO.	ZONE		CHANGE DESCRIPTION
PROJECT SPEC.	PACKAGING SPEC.	APPLICATION SPEC.	COPYRIGHT DELPHI CORPORATION AND/OR ITS AFFILIATES. ALL RIGHTS RESERVED. REVISED
APEX 1.2			THIS DRAWING IS THE PROPERTY OF DELPHI CORPORATION AND CONTAINS DELPHI CONFIDENTIAL INFORMATION. THE REPRODUCTION, DISTRIBUTION AND UTILIZATION OF THIS DOCUMENT OR ITS RELATED CAD DATA, AS WELL AS COMMUNICATION OF ANY CONTENT TO OTHERS, WITHOUT EXPRESS AUTHORIZATION, IS PROHIBITED.
TOLERANCES	±0.1	±2'	SURFACE FINISH
CONTRIBUTOR	SEE NOTE 5	COLOR	SEE CHART
DO NOT MEASURE DRAWING	TOOL NO.	ECO Loc. C46	AN
DATE	NAME	TITLE	DRAWING NUMBER
2015/02/18	FRANK HOLLER	PROJECT	PCC0682863
2015/02/03	MATT MAJOR	PROJECT	STATE
2015/02/03	SUSAN BIAN	PROJECT	PART NUMBER
2015/02/03	JIM CAMPBELL	ESR NO.	CAT. NO.
FILE NAME	PCC0682863	DOCUMENT UNDER PDS CONTROL, NO MODIFICATION ALLOWED OUTSIDE	See Table