

THIS DRAWING IS UNPUBLISHED. RELEASED FOR PUBLICATION
 © COPYRIGHT - By - ALL RIGHTS RESERVED.

| | |
|-------------|---------------------|
| PROJECT | PRJ-16-000909157 |
| PART NO. | X-2308349-X |
| DESCRIPTION | CRIMP FLANGES SMALL |
| CUSTOMER | GENERAL MARKET |

| REVISIONS | | | | | |
|-----------|-----|---------------------------|-----------|-----|------|
| P | LTR | DESCRIPTION | DATE | DWN | APVD |
| | A2 | REVISED PER ECR-16-014891 | 22FEB2017 | KK | SE |

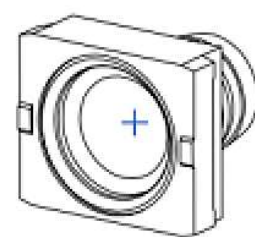
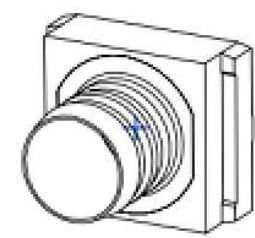
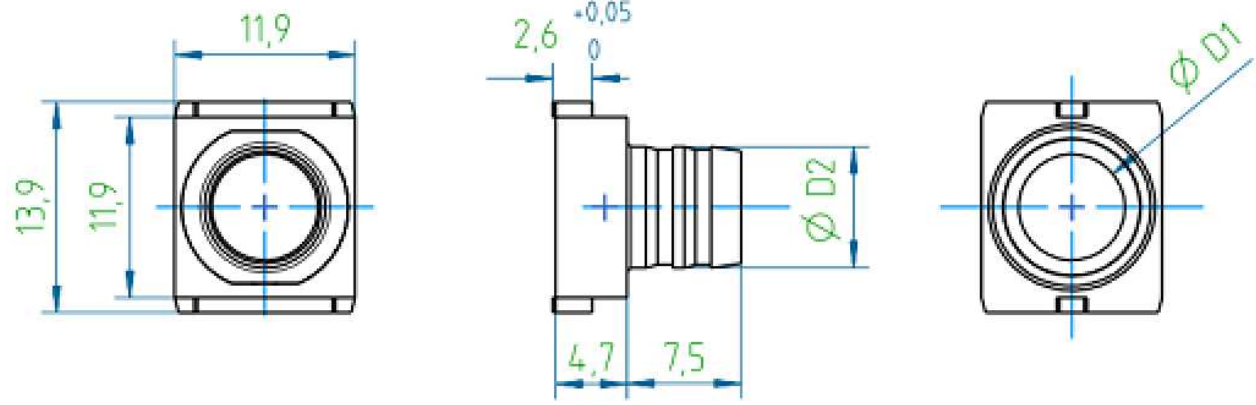

| | | | |
|-------------|-----------------------|-----|------|
| 2-2308349-4 | CRIMP FLANGE 14 SMALL | 3.0 | 4.0 |
| 2-2308349-3 | CRIMP FLANGE 13 SMALL | 3.5 | 4.5 |
| 2-2308349-2 | CRIMP FLANGE 12 SMALL | 4.0 | 5.0 |
| 2-2308349-1 | CRIMP FLANGE 11 SMALL | 4.5 | 5.5 |
| 2-2308349-0 | CRIMP FLANGE 10 SMALL | 5.0 | 6.0 |
| 1-2308349-9 | CRIMP FLANGE 9 SMALL | 5.5 | 6.5 |
| 1-2308349-8 | CRIMP FLANGE 8 SMALL | 5.7 | 6.7 |
| 1-2308349-7 | CRIMP FLANGE 7 SMALL | 6.0 | 7.0 |
| 1-2308349-6 | CRIMP FLANGE 6 SMALL | 6.5 | 7.5 |
| 1-2308349-5 | CRIMP FLANGE 5 SMALL | 7.0 | 8.0 |
| 1-2308349-4 | CRIMP FLANGE 4 SMALL | 7.6 | 8.5 |
| 1-2308349-3 | CRIMP FLANGE 3 SMALL | 8.0 | 9.0 |
| 1-2308349-2 | CRIMP FLANGE 2 SMALL | 8.5 | 9.5 |
| 1-2308349-1 | CRIMP FLANGE 1 SMALL | 9.0 | 10.0 |
| PART-NO. | DESCRIPTION | D1 | D2 |

- NOTES:
- FINISHING PROCESS: Cu2/Sn4 (FLANGE).
 - WEIGHT: 4 g.

| | | | | | | | | | | | | | | | | |
|------------------------------------------------------------------------------------------------------------------------------------------------------------------------------------------------------------------------------------------------------------------------|-----|-----------------------------------|-----------------------------|-------------------------|-----|-------|-----|-------|-----|-------|-----|--------|-----|-------------------|------------|--|
| THIS DRAWING IS A CONTROLLED DOCUMENT. | | DWN KIRAN K 29JUL2016 | STE TE Connectivity | | | | | | | | | | | | | |
| DIMENSIONS: mm | | CHK GUNASEKHAR G 29JUL2016 | | | | | | | | | | | | | | |
| TOLERANCES UNLESS OTHERWISE SPECIFIED: DIN ISO 2768 m. | | APVD GUNASEKHAR G 29JUL2016 | NAME CRIMP FLANGES SMALL | | | | | | | | | | | | | |
| <table border="1"> <tr> <td>0 PLC</td> <td>± -</td> </tr> <tr> <td>1 PLC</td> <td>± -</td> </tr> <tr> <td>2 PLC</td> <td>± -</td> </tr> <tr> <td>3 PLC</td> <td>± -</td> </tr> <tr> <td>4 PLC</td> <td>± -</td> </tr> <tr> <td>ANGLES</td> <td>± -</td> </tr> </table> | | 0 PLC | ± - | 1 PLC | ± - | 2 PLC | ± - | 3 PLC | ± - | 4 PLC | ± - | ANGLES | ± - | PRODUCT SPEC - | SIZE A3 | |
| 0 PLC | ± - | | | | | | | | | | | | | | | |
| 1 PLC | ± - | | | | | | | | | | | | | | | |
| 2 PLC | ± - | | | | | | | | | | | | | | | |
| 3 PLC | ± - | | | | | | | | | | | | | | | |
| 4 PLC | ± - | | | | | | | | | | | | | | | |
| ANGLES | ± - | | | | | | | | | | | | | | | |
| MATERIAL - | | FINISH - | CAGE CODE 00779 | DRAWING NO C-2308349 | | | | | | | | | | | | |
| | | WEIGHT | RESTRICTED TO - | | | | | | | | | | | | | |
| | | CUSTOMER DRAWING | | SCALE NTS | | | | | | | | | | | | |
| | | SHEET 1 OF 2 | | REV A2 | | | | | | | | | | | | |

THIS DRAWING IS UNPUBLISHED.

RELEASED FOR PUBLICATION

© COPYRIGHT - By -

ALL RIGHTS RESERVED.

REVISIONS

| P | LTR | DESCRIPTION | DATE | DWN | APVD |
|---|-----|-------------|------|-----|------|
| - | - | SEE SHEET 1 | - | - | - |

CRIMP BARREL, CRIMP INSERT AND CRIMP TOOL SELECTION PROCEDURE

SELECTION CHART AND CRIMP TOOLS

| Step | Description | Example |
|------|------------------------------------------------------------------------------------------------------------------------------------------------------------------------------------------------|------------------------------------------------------------------------------------------|
| 1. | Measure the outside cable diameter (3 times on different places at different angles) | OD = 6.5mm |
| 2. | Strip the cable and remove the cable braiding |  |
| 3. | Measure the diameter of the inner cable bundle including the foil | ID = 4.4mm |
| 4. | Select the crimp flange with a hole diameter next up to the cable bundle diameter | PN 2-2308349-1, ID=4.5mm, OD=5.5mm |
| 5. | Calculate the recommended barrel inner diameter with the following formula: <i>Recommended Inner crimp barrel diameter = OD of crimp flange + 2x(thickness of the cable jacket) + 0.2mm</i> | Thickness cable jacket = (6.5-4.4)/2=1.05mm Barrel ID= 5.5mm + 2x1.05 + 0.2mm = 7.8mm |
| 6. | Select the crimp barrel with the next size up | PN 1-2308350-7, ID=8.0mm, OD= 9.0mm |
| 7. | Order the correct crimp tool + crimp insert using the crimp barrel selection matrix | PN 1-2823557-1 & 1-2823558-3 |

| Picture | PN Crimp Barrel | Inner diameter | Outer diameter | PN Recommended crimp insert |
|--------------------------------------------------------------------------------------|-----------------|----------------|----------------|-----------------------------|
|  | 1-2308350-1 | 5.0 | 6.0 | 1-2823558-8 |
| | 1-2308350-2 | 5.5 | 6.5 | 1-2823558-9 |
| | 1-2308350-3 | 6.0 | 7.0 | 2-2823558-0 |
| | 1-2308350-4 | 6.5 | 7.5 | 2-2823558-1 |
| | 1-2308350-5 | 7.0 | 8.0 | 1-2823558-1 |
| | 1-2308350-6 | 7.5 | 8.5 | 1-2823558-2 |
| | 1-2308350-7 | 8.0 | 9.0 | 1-2823558-3 |
| | 1-2308350-8 | 8.5 | 9.5 | 1-2823558-4 |
| | 1-2308350-9 | 9.0 | 10.0 | 1-2823558-5 |
| | 2-2308350-0 | 9.5 | 10.5 | 1-2823558-6 |
| | 2-2308350-1 | 10.0 | 11.0 | 1-2823558-7 |
| | 2-2308350-2 | 10.5 | 11.5 | 2-2823558-9 |
| | 2-2308350-3 | 11.0 | 12.0 | 3-2823558-0 |
| | 2-2308350-4 | 11.5 | 12.5 | 3-2823558-1 |
| | 2-2308350-5 | 11.7 | 13.0 | 3-2823558-2 |
| | 2-2308350-6 | 12.0 | 13.0 | 3-2823558-3 |
| 2-2308350-7 | 12.5 | 13.5 | 3-2823558-4 | |
| 2-2308350-8 | 13.0 | 14.0 | 3-2823558-5 | |
| 2-2308350-9 | 13.7 | 15.0 | 3-2823558-6 | |
| 3-2308350-0 | 14.0 | 15.0 | 3-2823558-7 | |
| 3-2308350-1 | 14.5 | 15.5 | 3-2823558-8 | |
| 3-2308350-2 | 16.0 | 17.0 | 3-2823558-9 | |



1-2823559-1 stripping tool



1-2314418-1 Crimp flange insertion tool



Crimp tool 1-2823557-1
Crimp insert X-2823558-X

| | | | | | | | | | | | | | | | | |
|----------------------------------------------------------------------------------------------------------------------------------------------------------------------------------------------------------------------------------------------------------|---------|-----------------------------------|-------------------------------------------------------------------------------------------------------|--------------------|-----|-------|-----|-------|-----|-------|-----|--------|---------|-------------------|------------|--|
| THIS DRAWING IS A CONTROLLED DOCUMENT. | | DWN KIRAN K 29JUL2016 |  TE Connectivity | | | | | | | | | | | | | |
| DIMENSIONS: mm | | CHK GUNASEKHAR G 29JUL2016 | | | | | | | | | | | | | | |
| TOLERANCES UNLESS OTHERWISE SPECIFIED: | | APVD GUNASEKHAR G 29JUL2016 | NAME CRIMP FLANGES SMALL | | | | | | | | | | | | | |
| <table border="0"> <tr><td>0 PLC</td><td>± -</td></tr> <tr><td>1 PLC</td><td>± -</td></tr> <tr><td>2 PLC</td><td>± -</td></tr> <tr><td>3 PLC</td><td>± -</td></tr> <tr><td>4 PLC</td><td>± -</td></tr> <tr><td>ANGLES</td><td>± - ± -</td></tr> </table> | | 0 PLC | ± - | 1 PLC | ± - | 2 PLC | ± - | 3 PLC | ± - | 4 PLC | ± - | ANGLES | ± - ± - | PRODUCT SPEC - | SIZE A3 | |
| 0 PLC | ± - | | | | | | | | | | | | | | | |
| 1 PLC | ± - | | | | | | | | | | | | | | | |
| 2 PLC | ± - | | | | | | | | | | | | | | | |
| 3 PLC | ± - | | | | | | | | | | | | | | | |
| 4 PLC | ± - | | | | | | | | | | | | | | | |
| ANGLES | ± - ± - | | | | | | | | | | | | | | | |
| MATERIAL - | | FINISH - | APPLICATION SPEC - | CAGE CODE 00779 | | | | | | | | | | | | |
| | | WEIGHT | DRAWING NO C-2308349 | RESTRICTED TO - | | | | | | | | | | | | |
| CUSTOMER DRAWING | | | SCALE NTS | SHEET 2 OF 2 | | | | | | | | | | | | |
| | | | REV A2 | | | | | | | | | | | | | |