

LOC	DIST	REVISIONS					
-	-	P	LTR	DESCRIPTION	DATE	DWN	APVD
			A	REVISED PER ECR-14-007824	02JUNE2014	RS	EC
			B	ECO-15-015144: ADD UL.	30OCT2015	EC	EC

SAFETY ORGANIZATIONS

THIS FILTER HAS BEEN FORMALLY RECOGNIZED, CERTIFIED OR APPROVED BY THE LISTED AGENCY. THEREFORE, ALL TEST/REQUIREMENTS SPECIFIED IN THE LATEST REVISION OF THE FOLLOWING AGENCY STANDARDS HAVE BEEN MET: UL

RELIABILITY SPECIFICATIONS

STORAGE TEMPERATURE: -40°C TO +85°C
 HUMIDITY: 21 DAYS @ 40°C AND 95% RH

OPERATING SPECIFICATIONS

LINE CURRENT/VOLTAGE: 400 A, 690 VAC
 LINE FREQUENCY: 50-60 Hz
 NOMINAL LEAKAGE CURRENT: 10 mA
 MAXIMUM LEAKAGE CURRENT: 330mA @ 400V, 50HZ
 OPERATING AMBIENT TEMPERATURE RANGE @ RATED CURRENT, I : -10°C TO +50°C

IN AN AMBIENT, T, HIGHER THAN 50°C, THE MAXIMUM OPERATING CURRENT, I, IS AS FOLLOWS:

$$I_o = I_R \sqrt{\frac{100 - T_o}{50}}$$

TEST SPECIFICATIONS

INDUCTANCE, NOMINAL: 56.3 µH
 CAPACITANCE @ 1 kHz, 0.25 VAC MAX., 25°C ±1°C:
 LINE TO GROUND, NOMINAL: 2.62 µF
 LINE TO LINE, NOMINAL: 11.9 µF
 DISCHARGE RESISTOR L/G AND L/L I.R. 666kΩ / 666kΩ
 IR (NO DISCHARGE RESISTOR) 20°C, 50% RH AND 100VDC, MIN: 6000MΩ

RECOMMENDED RECEIVING INSPECTION HIPOT

LINE TO GROUND FOR 1 MINUTE: 2640 VDC
 LINE TO LINE FOR 1 MINUTE: 2520 VDC

FILTER APPROVAL:

THE BEST WAY TO SELECT AND QUALIFY A FILTER IS FOR YOUR ENGINEERING TO TEST THE UNIT IN YOUR EQUIPMENT.

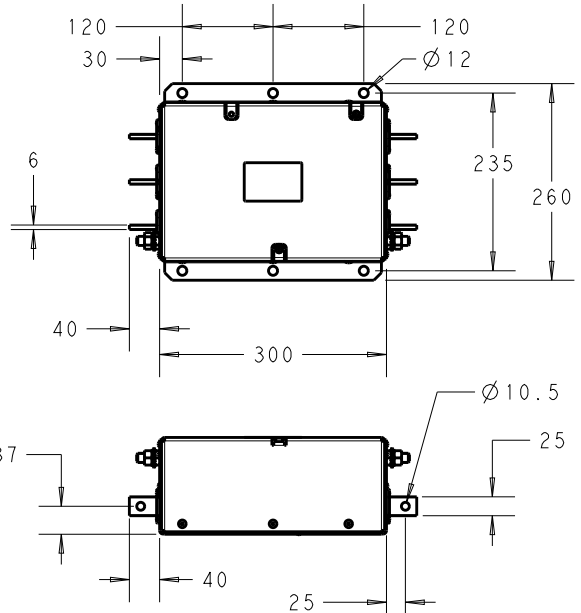
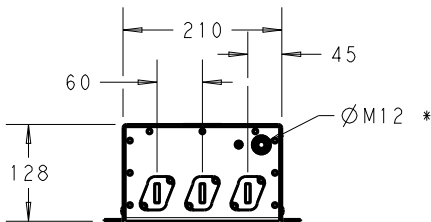
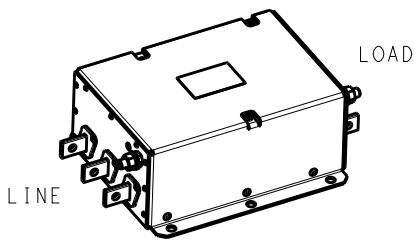

* DO NOT LOOSEN INNER GROUND NUTS. TORQUE OUTER GROUND NUTS TO: 25-30 NM [220-260 IN-LB]

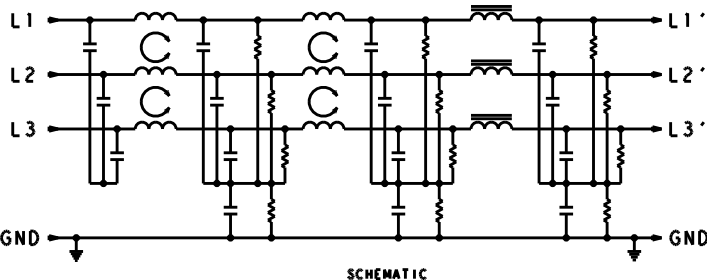

TYPICAL INSERTION LOSS
 COMMON MODE 50/50 Ω; DIFFERENTIAL MODE 100/100 Ω

MHz	0.01	0.05	0.15	0.5	1.0	3.0	5.0	10	30
CM	11	21	66	95	74	65	63	48	24
DM	31	43	74	68	62	51	47	40	30

20
 RELEASED FOR PUBLICATION
 ALL RIGHTS RESERVED.
 BY -
 COPYRIGHT 20

DIMENSIONS: mm	DWN RS 13DEC2013	MATERIAL	FINISH
TOLERANCES UNLESS OTHERWISE SPECIFIED:	CHK EC 13DEC2013	TE Connectivity	
0 PLC ±2 1 PLC ±1 2 PLC ±0.5 3 PLC ±0.2 4 PLC ±0.0001 ANGLES ±-	APVD EC 13DEC2013		
	PRODUCT SPEC	NAME	
	APPLICATION SPEC	400APH12P 3-PHASE DELTA FILTER	
WEIGHT	-	SIZE	RESTRICTED TO
Customer Drawing	-	CAGE CODE	-
		DRAWING NO	
		A 400779	
		C-8-1609148-8	
		SCALE	REV
		1:1	B
		SHEET	
		1 OF 1	