



### Main

Range of product	Harmony XB5
Product or component type	Wireless and batteryless transmitter
Device short name	XB5R
Bezel material	Plastic
Fixing collar material	Plastic
Mounting diameter	0.87 in (22 mm)
Transmission frequency	2405 MHz
Level or class	5M00G7W
Antenna type	Omnidirectional

### Complementary

Shape of signaling unit head	Round
Type of operator	Spring return push-button with transmitter
Operator profile	Flush red
Max power consumption in W	1 mW
Number of channels	1
Modulation technique	O-QPSK
Bandwidth	5 MHz
Antenna gain	0 dBi
Embedding depth	42 mm
CAD overall height	1.63 in (41.5 mm)
CAD overall width	1.18 in (30 mm)
CAD overall depth	1.69 in (43 mm)
Product weight	0.1 lb(US) (0.045 kg)
Operating travel	0.17 in (4.3 mm) total travel
Operating force	25 N C/O changing electrical state
Mechanical robustness	Free fall resistance (test level: 1000 mm) conforming to EN/IEC 60068-2-32
Standards	EN/IEC 60947-1 EN/IEC 60947-5-1 UL 508 CSA C22.2 No 14
Radio agreement	RSS SRRC ICASA ANATEL ARIB T66 FCC
Communication port protocol	Zigbee (green power) at 2.4 GHz conforming to IEEE 802.15.4
Maximum sensing distance	328.08 ft (100 m) in free field 82.02 ft (25 m) transmitter in a plastic box type XAL D and receiver in a metal enclosure 300 m transmitter in box type XAL D, receiver in metal enclosure and use relay-antenna
Acquisition time	2 ms
Response time	< 2 ms
Emission power	3 mW
Fixing mode	Fixing nut beneath head recommended torque: 2...2.4 N.m
Station name	XALD 1...5 cut-outs XALK 2...5 cut-outs
Electrical composition code	PW1

The information provided in this documentation contains general descriptions and/or technical characteristics of the products contained herein. This documentation is not intended as a substitute for and is not to be used for determining suitability or reliability of these products for specific user applications. It is the duty of any such user or integrator to perform the appropriate and complete risk analysis, evaluation and testing of the products with respect to the relevant specific application or use thereof. Neither Schneider Electric Industries SAS nor any of its affiliates or subsidiaries shall be responsible or liable for misuse of the information contained herein.

## Environment

ambient air temperature for storage	-40...158 °F (-40...70 °C)
ambient air temperature for operation	-13...131 °F (-25...55 °C)
relative humidity	95 % at 158 °F (70 °C) without condensation
IP degree of protection	IP65 on front face conforming to IEC 60529 IP30 on back face conforming to IEC 60529 IP65 on front face conforming to UL Type 12
IK degree of protection	IK03 conforming to IEC 50102
mechanical durability	1000000 cycles
shock resistance	25 gn (duration = 6 ms) 6000 shocks conforming to IEC 60068-2-27 30 gn (duration = 18 ms) half sine wave acceleration conforming to IEC 60068-2-27 50 gn (duration = 11 ms) half sine wave acceleration conforming to IEC 60068-2-27
vibration resistance	+/- 10 mm (f = 2...11 Hz) conforming to IEC 60068-2-6 5 gn (f = 11...500 Hz) conforming to IEC 60068-2-6
electromagnetic compatibility	Immunity for industrial environments Radiated emission Electrostatic discharge immunity test (test level: 8 kV - in free air (in insulating parts)) Electrostatic discharge immunity test (test level: 6 kV - on contact (on metal parts)) Susceptibility to electromagnetic fields (test level: 10 V/m - 80...2000 MHz) Susceptibility to electromagnetic fields (test level: 3 V/m - 80...2700 MHz, distance = 20 m)
product certifications	CCC CSA C-Tick GOST UL BT 2006/95/EC
directives	2004/108/EC - electromagnetic compatibility 1999/5/EC - R&TTE directive

## Offer Sustainability

Green Premium product	Green Premium product
Compliant - since 1040 - Schneider Electric declaration of conformity	Compliant - since 1040 - Schneider Electric declaration of conformity
Reference not containing SVHC above the threshold	Reference not containing SVHC above the threshold
Available	Available
Available	Available
WARNING: This product can expose you to chemicals including:	WARNING: This product can expose you to chemicals including:
Nickel compounds, which is known to the State of California to cause cancer, and	Nickel compounds, which is known to the State of California to cause cancer, and
Di-isodecyl phthalate (DIDP), which is known to the State of California to cause birth defects or other reproductive harm.	Di-isodecyl phthalate (DIDP), which is known to the State of California to cause birth defects or other reproductive harm.
For more information go to <a href="http://www.p65warnings.ca.gov">www.p65warnings.ca.gov</a>	For more information go to <a href="http://www.p65warnings.ca.gov">www.p65warnings.ca.gov</a>

## Contractual warranty

Warranty period	18 months
-----------------	-----------

## Wireless and Batteryless Pushbutton - Transmitter

### With Plastic Pushbutton without Cap

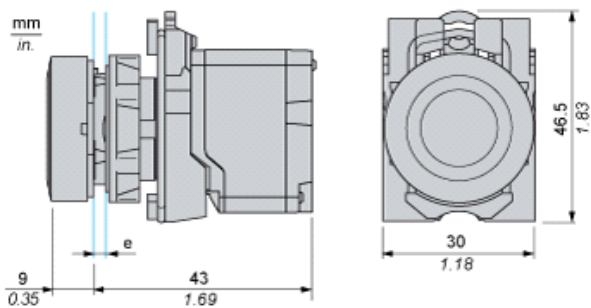

e: panel thickness 1 to 6 mm / 0.039 to 0.24 in.

### Transmitter Mounting

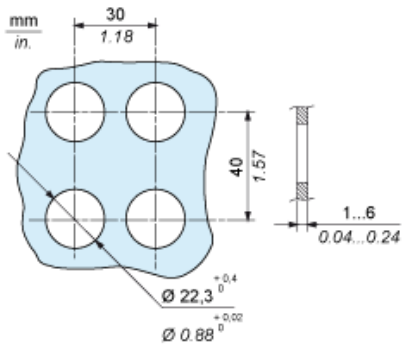

### Transmitter Clearance in Free Field Unobstructed

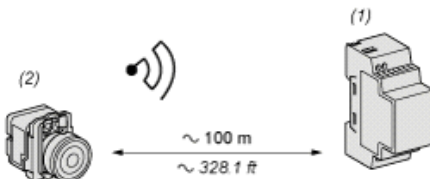

- (1): Receiver
- (2): Transmitter

### Transmitter Clearance in a Metal Enclosure

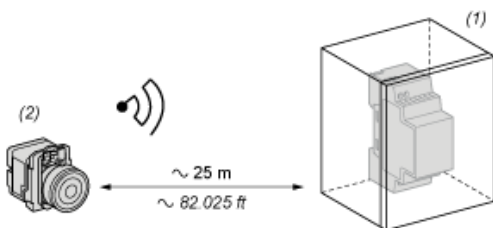

- (1): Metal enclosure
- (2): Transmitter

The range is reduced if the transmitter is placed in a metal enclosure (reduction factor: approx 10%)

Glass window	10...20 %
Plaster wall	30...45 %
Brick wall	60 %
Concrete wall	70...80 %
Metal structure	50...100 %