

THIS DOCUMENT IS THE PROPERTY OF KEYSTONE ELECTRONICS CORP. AND SHALL NOT BE REPRODUCED, DISTRIBUTED OR USED AS A BASIS FOR MANUFACTURE WITHOUT PRIOR WRITTEN PERMISSION FROM KEYSTONE ELECTRONICS CORP.

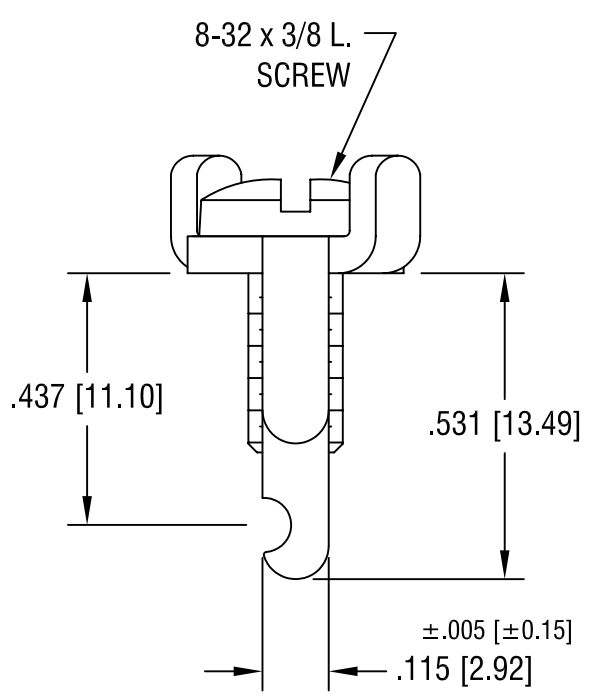
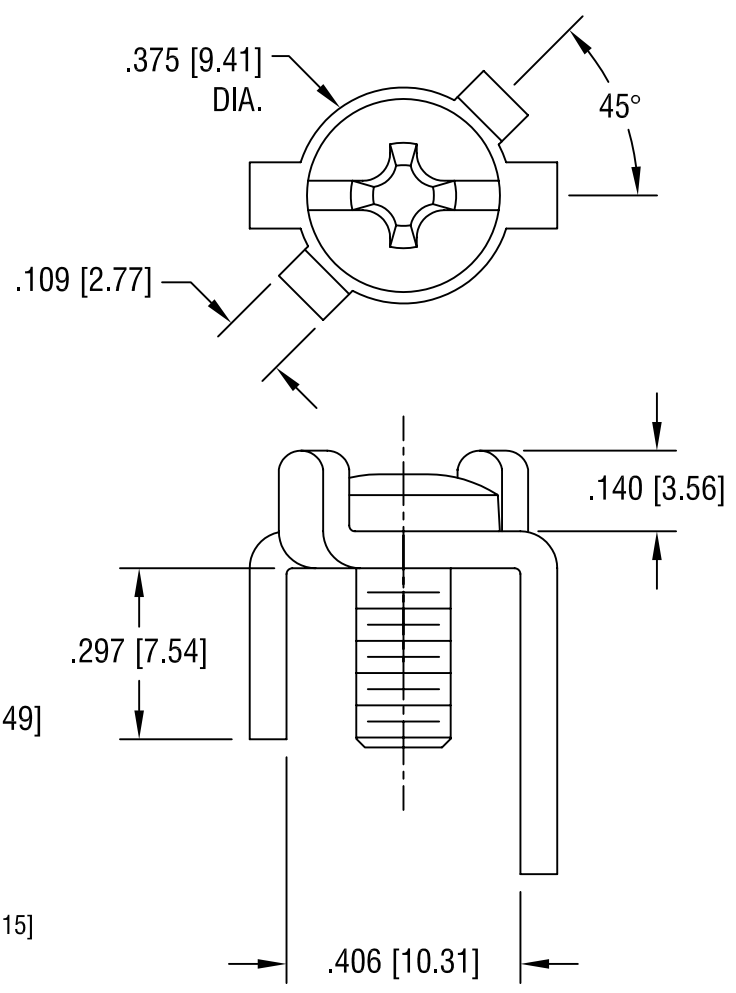
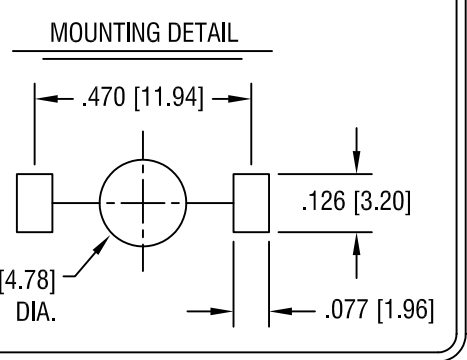

NOTES:

- 1. TERMINAL:  
MAT'L - .064 [1.63] TH'K BRASS, TIN PLATE
- SCREW:  
MAT'L - BRASS, NICKEL PLATE

<b>KEYSTONE ELECTRONICS CORP.</b>			
ASTORIA, N.Y. 11105-2017			
PART NAME		SCREW TERMINAL	
MATERIAL		AS NOTED	
FINISH	AS NOTED	DRN BY	BOONE
		APP'D	LN
		DATE	4.13.82
		SCALE	3X
TOLERANCES	INCH [MM]	CODE	DWG NO.
DECIMAL	±.010 [±0.25]	C	<b>1209</b>
ANGULAR	± 2°		
UNLESS OTHERWISE SPECIFIED			

5.12.05	CHANGE AS PER ECN 05-025	D
DATE	DESCRIPTION	REV.