

General Specifications

Motor Protection:

Auto Restart/Polarity Protection

Insulation Resistance:

10M Ω by DC500V Megger

Dielectric Withstand Voltage: AC 700V 1s

Allowable Ambient Temperature Range:

-10°C ~ +70°C (Operating)

-30°C ~ +70°C (Storage)

(non-condensing environment)

Expected Life

Failure Rate: 10%

40°C 70,000 Hours

Material

Casing : Plastic (Black) 94V-0

Impeller : Plastic (Black) 94V-0

Bearing : Ball Bearing

Lead Wire : UL10368, AWG 26/28

Inlet Fan : +Red, -Black

Tach Sig. : White

PWM Control : Brown

Outlet Fan: Orange

Gray

Yellow

Blue

Characteristic Curves

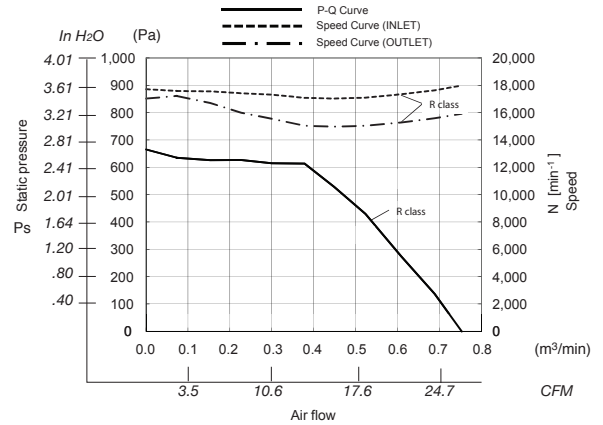

Outline

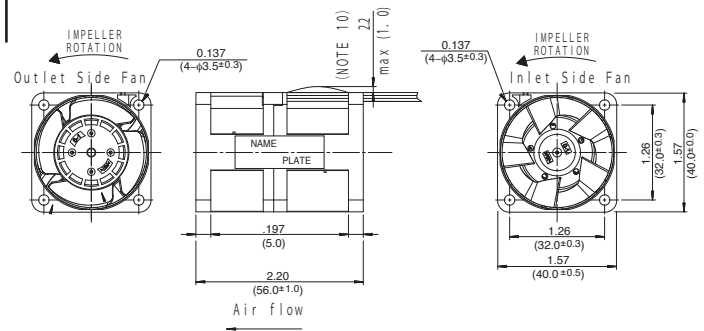

Panel Cut-Outs

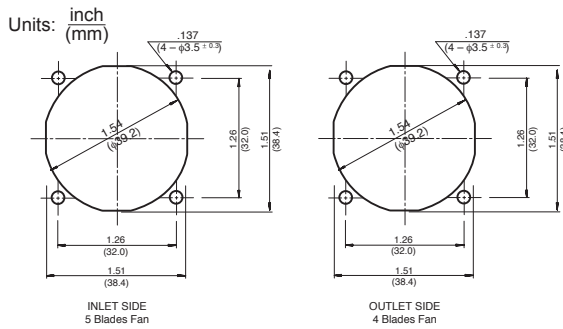

Reference PWM Duty Vs. Speed Curve

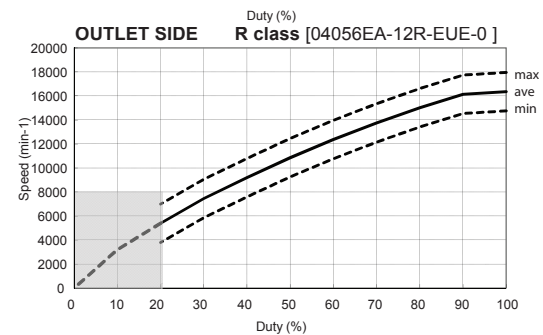
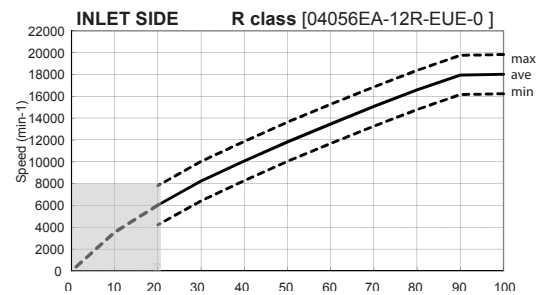

PWM Control Voltage

INLET/OUTLET

V_{st} = 0V ~ 0.4V Stop (On Duty 0%)

V_{st} = 4.0V ~ 5.0V Full Speed (On Duty 100%)

V_{st} = Open Full Speed

(At rating Voltage, V_{st}=5.0V, f=25.0 kHz, T_a=20°C)

Specifications

MODEL	Product No.	Rated Voltage	Operating Voltage	Current	Input Power	Speed Air (min ⁻¹) ¹		Max. Flow (m ³ /min) ¹		Max. Static Pressure (Pa) ¹		Noise (dB) ¹	Mass (g)
		(V)	(V)	(A) ¹	(W) ¹	Inlet	Outlet	CFM ¹	(m ³ /min) ¹	in H ₂ O	(Pa) ¹	(dB) ¹	(g)
04056EA-12X-EUE-0	R	12	10.8 ~ 13.2	0.85	10.20	18,000	16,000	26.1	0.74	2.65	660.0	66.5	90

Rotation: Clockwise

Airflow Outlet: Air Out Over Struts

*1: Average Values in Free Air