

THIS DRAWING IS UNPUBLISHED. RELEASED FOR PUBLICATION
 © COPYRIGHT - By - ALL RIGHTS RESERVED.

REVISIONS				
P	LTR	DESCRIPTION	DATE	APVD
AM2		REVISED PER ECO-16-014786	19OCT2016	RS MZ

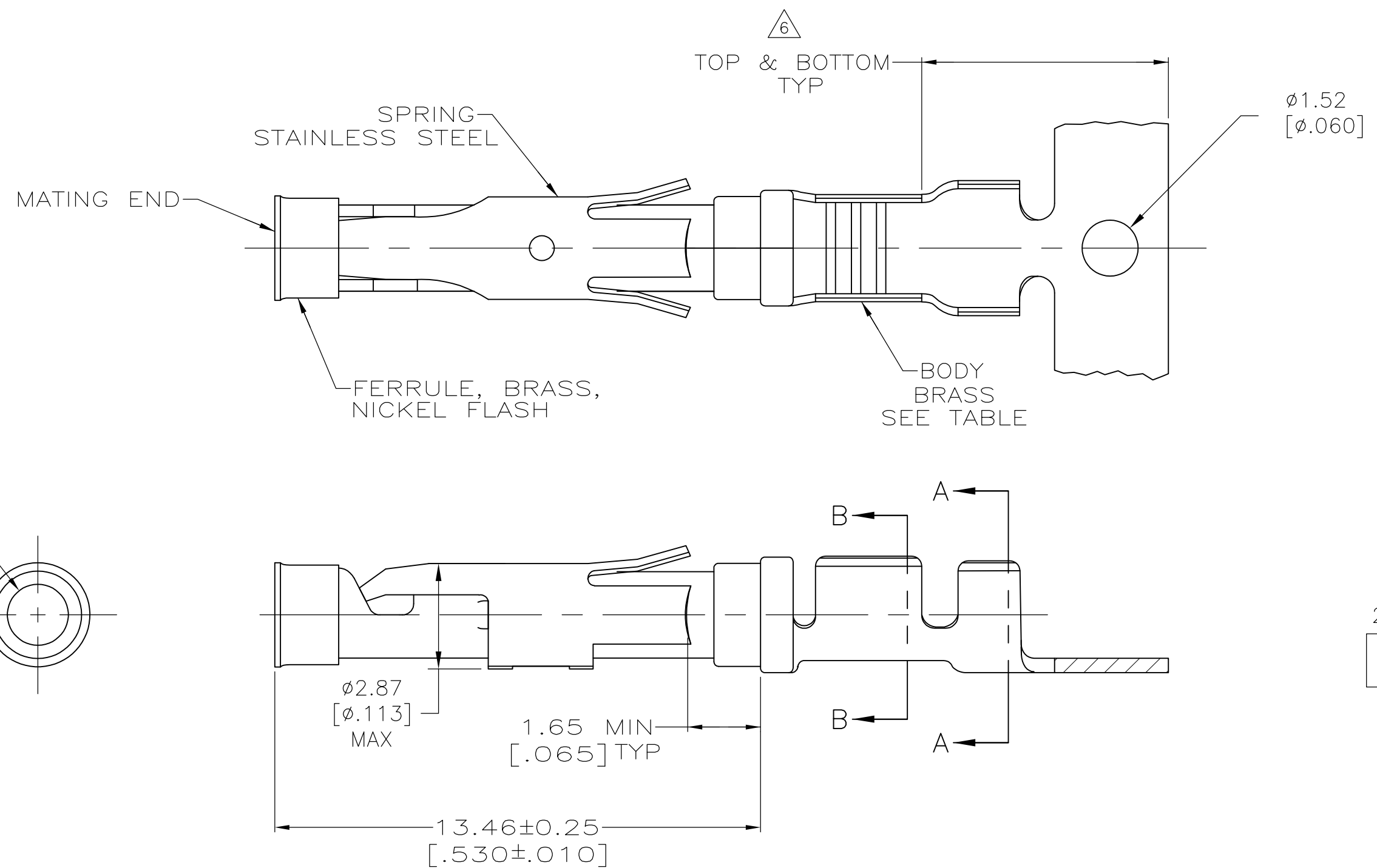

$\Delta 1.27\mu\text{m} [0.00050]$ MIN TIN PER MIL-T-10727 OVER
 $0.76\mu\text{m} [0.00030]$ MIN NICKEL PER QQ-N-290.

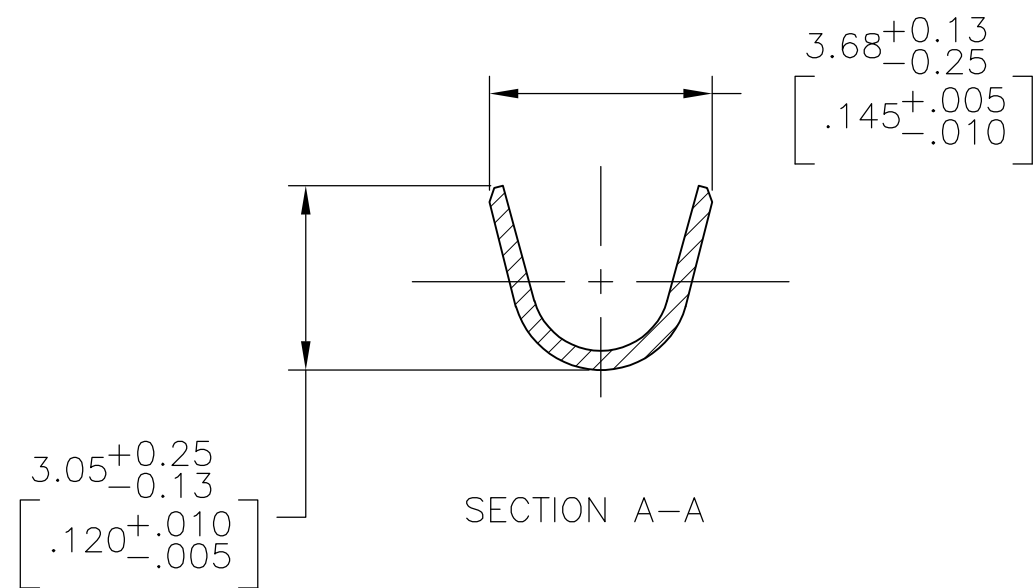
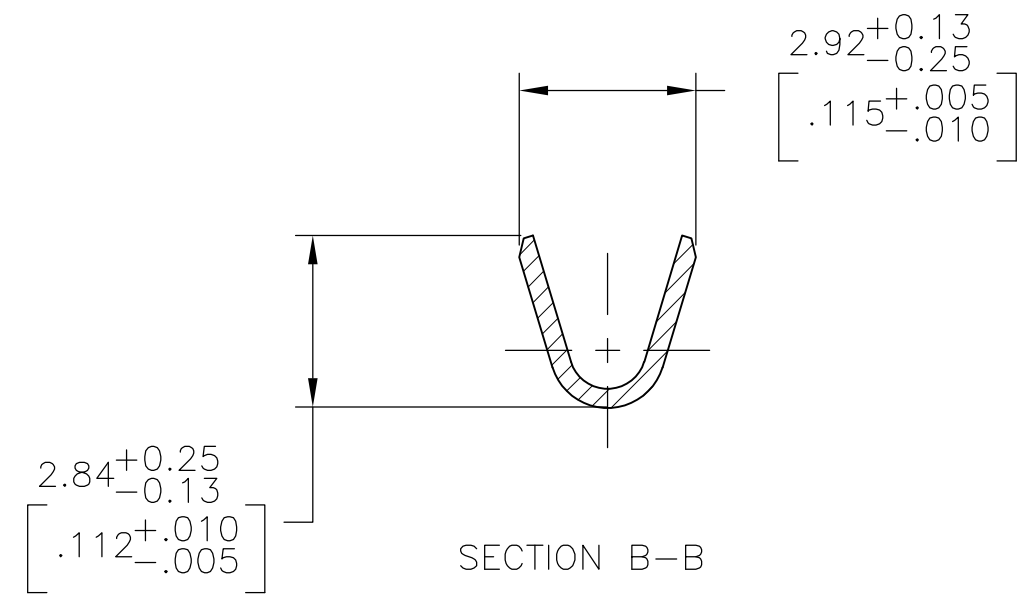
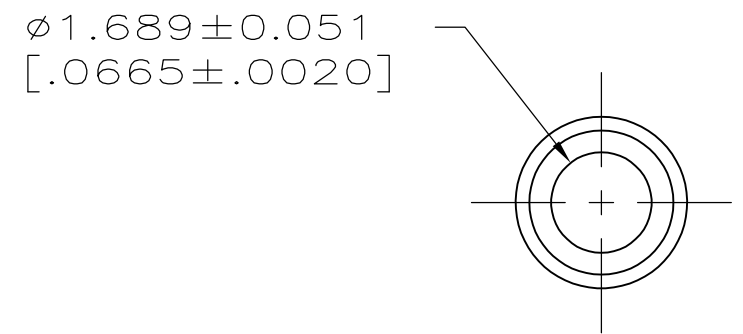

- $\Delta 1$ $0.76\mu\text{m} [0.00030]$ MIN GOLD PER MIL-G-45204 ON MATING END FOR A LENGTH OF 5.08 [.200] MIN WITH $1.27\mu\text{m} [0.00050]$ MIN MATTE TIN PLATE IN WIRE CRIMP AREA, BOTH OVER $0.76\mu\text{m} [0.00030]$ MIN NICKEL PER QQ-N-290.
- $\Delta 2$ $1.27\mu\text{m} [0.00050]$ MIN TIN-LEAD PER MIL-T-10727 OVER $0.76\mu\text{m} [0.00030]$ MIN NICKEL PER QQ-N-290.
- $\Delta 3$ $0.76\mu\text{m} [0.00030]$ MIN GOLD PER MIL-G-45204 ON MATING END FOR A LENGTH OF 5.08 [.200] MIN WITH A UNIFORM GRADIENT TO $0.25\mu\text{m} [0.00010]$ MIN GOLD PER MIL-G-45204 ON THE REMAINDER OVER $0.76\mu\text{m} [0.00030]$ MIN NICKEL PER QQ-N-290.
- $\Delta 4$ $0.38\mu\text{m} [0.00015]$ MIN GOLD PER MIL-G-45204 ON MATING END FOR A LENGTH OF 5.08 [.200] MIN WITH $1.27\mu\text{m} [0.00050]$ MIN MATTE TIN PLATE IN WIRE CRIMP AREA, BOTH OVER $0.76\mu\text{m} [0.00030]$ MIN NICKEL PER QQ-N-290.
- $\Delta 5$ $1.27\mu\text{m} [0.00050]$ MIN GOLD PER MIL-G-45204 ON MATING END FOR A LENGTH OF 5.08 [.200] MIN WITH GOLD FLASH ON REMAINDER OVER $1.90\mu\text{m} [0.00075]$ MIN NICKEL PER QQ-N-290.
- $\Delta 6$ GOLD PLATING NEED NOT APPEAR IN THIS AREA EXCEPT 1-66100-3 HAS GOLD PLATING ON INSULATION BARREL.
- $\Delta 7$ REVERSE REELED FOR MINI-APPLICATOR.
- 8 ALL PART NUMBERS ON THIS DRAWING HAVE APPLICATION TOOLING AVAILABLE TO CRIMP 18-16 WIRE AWG WITH AN INSULATION RANGE OF $\phi 2.03-2.54 [0.080-.100]$. ADDITIONALLY, LOOSE PIECE AND REVERSE REELED PART NUMBERS HAVE APPLICATION TOOLING AVAILABLE TO CRIMP 0.75mm^2 WIRE WITH AN INSULATION RANGE OF $\phi 1.35-1.65 [0.053-.065]$ OR 1.0mm^2 WIRE WITH AN INSULATION RANGE OF $\phi 1.45-1.80 [0.057-.071]$.
- $\Delta 9$ $0.38\mu\text{m} [0.00015]$ MIN GOLD PER MIL-G-45204 ON MATING END FOR A LENGTH OF 5.08 [.200] MIN, $1.27\mu\text{m} [0.00050]$ MIN TIN-LEAD PER MIL-T-10727 FOR A LENGTH OF 5.69 [.224] MIN ON OPPOSITE END, BOTH OVER $1.27\mu\text{m} [0.00050]$ MIN NICKEL PER QQ-N-290 ON ENTIRE CONTACT.

SUPERCEDED BY 66100-8

OBSOLETE	EUROPE	$\Delta 7$	$\Delta 10$	NONE	—2-66100-2—
OBSOLETE		$\Delta 7$	$\Delta 1$	NONE	—2-66100-1—
		STANDARD	$\Delta 10$	1-66101-9	2-66100-0
		$\Delta 7$	$\Delta 10$	1-66101-9	1-66100-9
		$\Delta 7$	$\Delta 9$	1-66101-4	—1-66100-7—
			$\Delta 5$	—	—1-66100-3—
		$\Delta 7$	$\Delta 1$	66101-4	66100-9
		$\Delta 7$	$\Delta 4$	66101-3	66100-8
		$\Delta 7$	$\Delta 2$	66101-2	66100-7
		$\Delta 7$	$\Delta 3$	66101-1	66100-6
		STANDARD	$\Delta 1$	66101-4	66100-4
		STANDARD	$\Delta 4$	66101-3	66100-3
		STANDARD	$\Delta 2$	66101-2	66100-2
		STANDARD	$\Delta 3$	66101-1	66100-1
	TE ASSEMBLY LOCATION	REELING	BODY FINISH	LOOSE PIECE REF	PART NO.

THIS DRAWING IS A CONTROLLED DOCUMENT.

DIMENSIONS: mm [INCHES]	TOLERANCES UNLESS OTHERWISE SPECIFIED: 0 PLC ± - 1 PLC ± - 2 PLC ± 0.13 [.005] 3 PLC ± - 4 PLC ± - ANGLES ± -	DWN V. FURLER 11JUL03 CHK G. STEINHAUER 11JUL03 APVD G. STEINHAUER 11JUL03		
MATERIAL SEE CALLOUTS	FINISH SEE CALLOUTS	PRODUCT SPEC APPLICATION SPEC	NAME: SOCKET ASSEMBLY, .062, TYPE III+ SIZE: A2 CAGE CODE: 00779 DRAWING NO: C=66100 RESTRICTED TO: - SCALE: 8:1 SHEET: 1 of 1 REV: AM2	