

## VQ500 Series Datasheet

### Catalytic Combustible Gas Sensor (4-Series)

The VQ500 Series is a complete range of miniature, fully certified, flameproof sensor heads containing a high quality, low power pellistor pair optimised for the detection of combustible gases or % volume gases in thermal conductivity mode. They have an outline identical to modern miniature electrochemical cells and are ideally suited for use in portable instruments.

Within the VQ500 Series there are specific sensors that are able to detect most combustible gases and vapours and ammonia at LEL levels. The thermal conductivity version will detect most gases at % volume concentrations which have thermal conductivities different from that of air.

The VQ500ZD/W variants have had a temperature test performed during its manufacture to confirm the temperature performance of the sensor meets the datasheet ensuring compliance to the various mining performance standards (Group 1) with regard to the temperature performance.

The VQ548ZD-S variant has extra burn-in for enhanced stability.

### FEATURES

- Optimised for combustible gases and vapours
- Thermal conductivity versions available
- Certified explosion proof component
- Integral pellistors
- Low power
- Standard miniature body size
- Poison resistant – silicones and hydrogen sulfide
- Shock resistant
- ATEX certified
- IECEx certified
- CSA certified
- UL recognised
- Temperature Rated between -40°C and +55°C



### OPERATING PRINCIPLES

The detector consists of a fine coil of platinum wire embedded in a ceramic bead incorporating a noble metal catalyst. The coil acts both as an electrical heater and as a resistance thermometer. The bead is mounted on a header with connecting leads and is surrounded by a metal can with the end open to the atmosphere.



If a flammable gas is present when the bead is heated to about 400 to 500 °C, the gas will oxidise and the resultant release of energy will heat the bead still further. This increase in temperature is detected as an increase in resistance of the coil.

The temperature of the coil is also affected by ambient temperature and by variations in thermal conductivity of the air caused by the possible presence of inert gases such as carbon dioxide. To compensate for temperature changes not caused by the oxidation of the flammable gas a second, inert bead is used. This compensator is made in the same way as a detector bead except that instead of incorporating a catalyst in the ceramic bead, the bead is treated so that oxidation cannot take place. The two beads are then used in a circuit that detects the difference in their resistances. Since the two beads are generally of a different colour, they have different emissivity and hence different slope resistances. Therefore, to obtain the best temperature performance, it is necessary to connect a fixed resistor in parallel with the compensator to correct for its higher slope resistance.

### TECHNICAL SPECIFICATION

#### Mechanical

Dimensions	see outline, page 3
Body material	Stainless Steel
Weight	22g

#### Environmental

Temperature range for operation and storage	-40 to +55 °C
Humidity range for operation and storage	0 to 80% (non-condensing)

#### Electrical

Supply Voltage	3.00 V to 4.25 V; (Depending upon type)
Supply Power	135 mW to 230 mW (Depending upon type)

Whilst SGX has taken care to ensure the accuracy of the information contained herein it accepts no responsibility for the consequences of any use thereof and also reserves the right to change the specification of goods without notice. SGX accepts no liability beyond the set out in its standard conditions of sale in respect of infringement of third party patents arising from the use of SGX products in accordance with information contained herein. In case of modification of the product, SGX disclaims all liability.

## PERFORMANCE

<b>Linearity:</b> Catalytic Thermal Conductivity	Linear up 60%LEL Refer to Pellistor Application Note 5
<b>Response Time (T<sub>90</sub>)</b>	T <sub>90</sub> < 20 seconds
<b>Long Term Zero Drift</b> - ZD-S Variants - All other Types	<5%LEL / month (based upon a 1 month period) <5%LEL / month (based upon a 12 month period)
<b>Long Term Sensitivity Drift</b> - ZD-S Variants - All other Types	<5%Full-Scale / month (based upon a 1 month period) <5% Full-Scale / month (based upon a 12 month period)
<b>Zero Offset with Temperature (ZD/W Variant Only)</b>	≤ 0.2% methane variation between -10°C to +40°C when compare to the 20°C reading
<b>Warranty Period</b>	12 months

## MAXIMUM GAS CONCENTRATIONS

(See Note d)

VQ546M, VQ546MR	100%v/v
VQ547TS, VQ548, VQ549	100%LEL

## NOTES

- The sensitivity is measured in the standard manufacturer's test jig with no filter or other material between the gas and the sinter.
- A temperature test is performed on all ZD/W sensors to confirm the temperature performance of the sensor is within specification.
- A burn-in for several weeks is performed followed by a week drift test.
- The calibration of the sensor should be checked if it has been exposed, whilst operating, to gas concentrations greater than the Lower Explosive Limit. Exceeding this limit may permanently damage the sensor.
- It is not recommended to direct the gas flow onto the sinter.
- The response to flammable vapours, especially heavy aromatic compounds, may be different to the theoretical figures (k factors) listed in Pellistor Application Note 3. These k factors are for guidance only and ideally the sensors should be calibrated to the actual vapour concentration required.
- Under no circumstances should the sensor pins be soldered directly to a PCB or wires. Excessive heat could cause irreparable damage to sensor elements. Information on the recommended sockets can be found on our website under the Frequently Asked Questions (FAQ) section.

## OPERATION

The output of a sensor is dependent on a complex combustion process established around the sensing beads. It is imperative that the layers of gas around the beads are not disturbed, otherwise the bead temperature and hence device output will change. The design of the VQ500 housing achieves this requirement, provided the user takes care not to allow gas flows directly onto the sinter.

It is recommended that the detector and compensator be run in a Wheatstone Bridge circuit so that a difference signal may be obtained. A suitable circuit is shown in this document. In use, the bridge supply voltage should be stable to within + 0.1 V, or the output in clean air may change in sympathy. Although it is generally recommended that pellistors should be run with a constant voltage supply to the bridge, it is possible to use a constant current supply provided that the voltage across the bridge in clean air remains within the recommended limits.

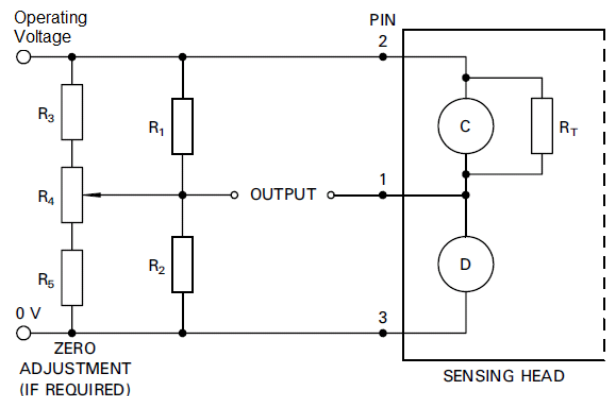

$$R_1 = R_2 = 500\Omega \text{ to } 10 \text{ k}\Omega$$

$$R_3 = R_5 \approx 10R_1$$

$$R_4 \approx 20R_1$$



## PRODUCT VARIANTS

Product	Operating Voltage (V d.c)	Sensor Current (mA)	Minimum Sensitivity (mV/%Vol) (See note a)	Offset (mV)	Poison Resistance	Outline (Page 3)	Description	Routine Temperature Tested (See note b)	Routine Burn-In and Drift Test (See note c)
VQ546M	4.25 ±0.1	50 – 60	-4.0 (1% Methane)	±15	Not Required	A	Low Power, Thermal Conductivity Sensor, methane. Negative (M) or positive (MR) output	No	No
VQ546MR			+4.0 (1% Methane)					No	No
VQ547TS	3.0 ±0.1	40 – 50	21 (1.5% Ammonia)	±30	Some	A	Low Power, LEL Ammonia Sensor	No	No
VQ548ZD	3.0 ±0.1	67 – 80	20 (1% Methane)	±20	Silicones & H <sub>2</sub> S	B	Low Power, LEL methane sensor, silicone poisoning, H <sub>2</sub> S and Shock Resistant	No	No
VQ548ZD/W								Yes	No
VQ548ZD-S								No	Yes
VQ549ZD	4.25 ±0.1	50 – 60	30 (1% Methane)	±20	Silicones & H <sub>2</sub> S	B	Low Power, LEL methane sensor, silicone poisoning, H <sub>2</sub> S and Shock Resistant	No	No
VQ549ZD/W								Yes	No

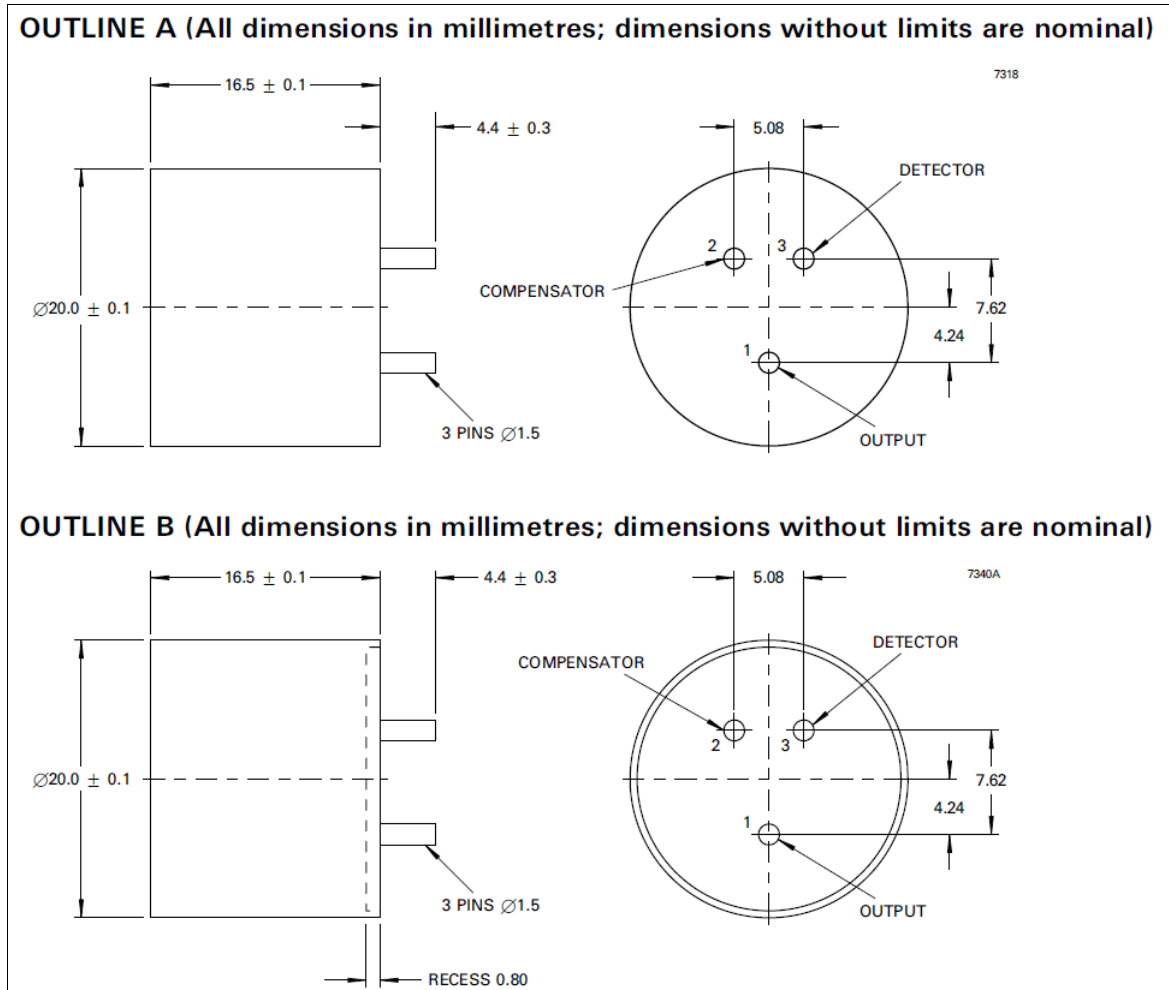
## OUTLINE DRAWING



## CERTIFICATION

	<b>EC Type-Examination Certificate Numbers:</b>	<b>ATEX:</b> Sira 01ATEX1073U <b>IECEX:</b> IECEX SIR 04.0014U	
	<b>Issued by:</b>	Sira Test & Certification Service Rake Lane Ecclestone Chester, CH4 9JN UK	
	<b>Have been assessed to the following harmonized standards:</b>	EN 60079-0:2012 & IEC 60079-0:2011 (Ed. 6) Electrical apparatus for explosive gas atmospheres – General requirements  IEC 60079-1:2014 (Ed. 7) Electrical apparatus for explosive gas atmospheres Flameproof enclosures “d”	
	<b>Product Marking:</b>	<b>ATEX:</b> II 2G Ex db IIC Gb I M2 Ex db I Mb  <b>IECEX:</b> Ex db IIC Gb Ex db I Mb	Ta -40°C to +55°C,  Pi: 2.5 W
	The Canadian Standards Association has issued a component certification for the VQ500 Series as an Explosion Proof Enclosure for use in Class I hazardous locations. It has satisfied the requirements of CSA standard C22.2 No. 30-M 1986. Certificate No. 2589677. The Canadian Standards Association has also assessed the VQ500 Series to UL 1203 (4 <sup>th</sup> Edition).		
	Underwriters Laboratories Inc. recognise the VQ500 Series as a component for use in intrinsically safe apparatus in Class 1, Division 1, Groups A, B, C and D hazardous locations. It has satisfied the requirements of UL 913, 7th edition. File E186043.		

### INSTRUCTIONS SPECIFIC TO HAZARDOUS AREA INSTALLATIONS

(Ref. EU ATEX Directive 2014/34/EU)

- The VQ500 Series Gas Sensing Heads are component approved only and may not be used as standalone items in a hazardous area without further protection.
- The VQ500 Series Sensing head shall be used in conjunction with apparatus providing an intrinsically safe supply having a maximum output (P<sub>o</sub>) not greater than 2.5 W.
- For the purpose of temperature classification of the apparatus in which the VQ500 Series Gas Sensing Head is used, the maximum temperature rise on any external surface does not exceed 64 °C.
- When the VQ500 Series component is utilized in equipment that is intended to be used in Group I applications, it shall be suitably protected to ensure that it will withstand an impact energy in excess of 7 J low risk of impact value specified in EN 60079-0 clause 26.4.
- The VQ500 Series Gas Sensing Heads have not been assessed as a safety device (EHSR 1.5).
- There are no user-serviceable parts in the component.
- The end-user/installer shall be aware that the certification of the VQ500 Series Gas Sensing Heads relies on the following materials used in its construction, which are suitable for most common applications:
  - Enclosure .....Stainless steel
  - Mesh .....Stainless steel
  - Bushing .....Epoxy resin
 In accordance with the Note in EN60079-0:2006 clause 6.1(a), the end-user/installer shall inform the manufacturer of any adverse conditions that the VQ500 Series Gas Sensing Heads may encounter. This is to ensure that the VQ500 Series Gas Sensing Heads are not subjected to conditions that may cause degradation of these materials.
- The VQ500 Series Gas Sensing Head shall only be used in an ambient temperature range of -40°C and +55°C.