

THIS DRAWING IS UNPUBLISHED. RELEASED FOR PUBLICATION MAY, 2006.
 © COPYRIGHT 2006 BY TYCO ELECTRONICS CORPORATION. ALL RIGHTS RESERVED.

LOC	DIST	REVISIONS					
E	B	P	LTR	DESCRIPTION	DATE	DWN	APVD
		E		ECR-10-025778	18FEB2011	RITA	MY

- NOTES:**
- 1 PACK IN ACCORDANCE WITH AMP SPEC 107-3275
 - 2 100 TRAY PACK IN ACCORDANCE WITH AMP SPEC 107-3275
 - 3 Au PLATING
 - 4 Ni PLATING
 - 5 THIS ITEM MUST BE WHITE
 - 6 HAND TOOL : 9-1478240-0
 - 7 DIE SET : 9-1478242-0
 - 8 ELECTRICAL CHARACTERISTICS
 FREQUENCY RANGE: DC - 11 GHz
 NOMINAL IMPEDANCE: 50 Ohm
 INSULATION RESISTANCE: 5000 MOhm
 WORKING VOLTAGE: 1000 Volts RMS at Sea Level
 DIELECTRIC WITHSTAND VOLTAGE: 2500 Volts RMS Max
 CONTACT RESISTANCE:
 CENTRE CONTACT: 1.00 mOhm Max
 OUTER CONTACT: 1.00 mOhm Max
 VSWR @ 4GHz: 1.30:1 Max
 INSERTION LOSS dB @ x 4 GHz: 0.30 Max
 - 9 MECHANICAL CHARACTERISTICS
 COUPLING NUT RETENTION FORCE: 445N Min
 CABLE RETENTION FORCE: 170N Min
 DURABILITY: 500 Cycles Min
 - 10 ENVIRONMENTAL CHARACTERISTICS
 OPERATING TEMPERATURE: -65 to +165 DegC
 - 11 FOR TECHNICAL DATA REFER TO YOUR LOCAL TYCO ELECTRONICS SALES OFFICE
 - 12 ALL DIMENSIONS ARE NOMINAL FOR REFERENCE ONLY UNLESS OTHERWISE STATED

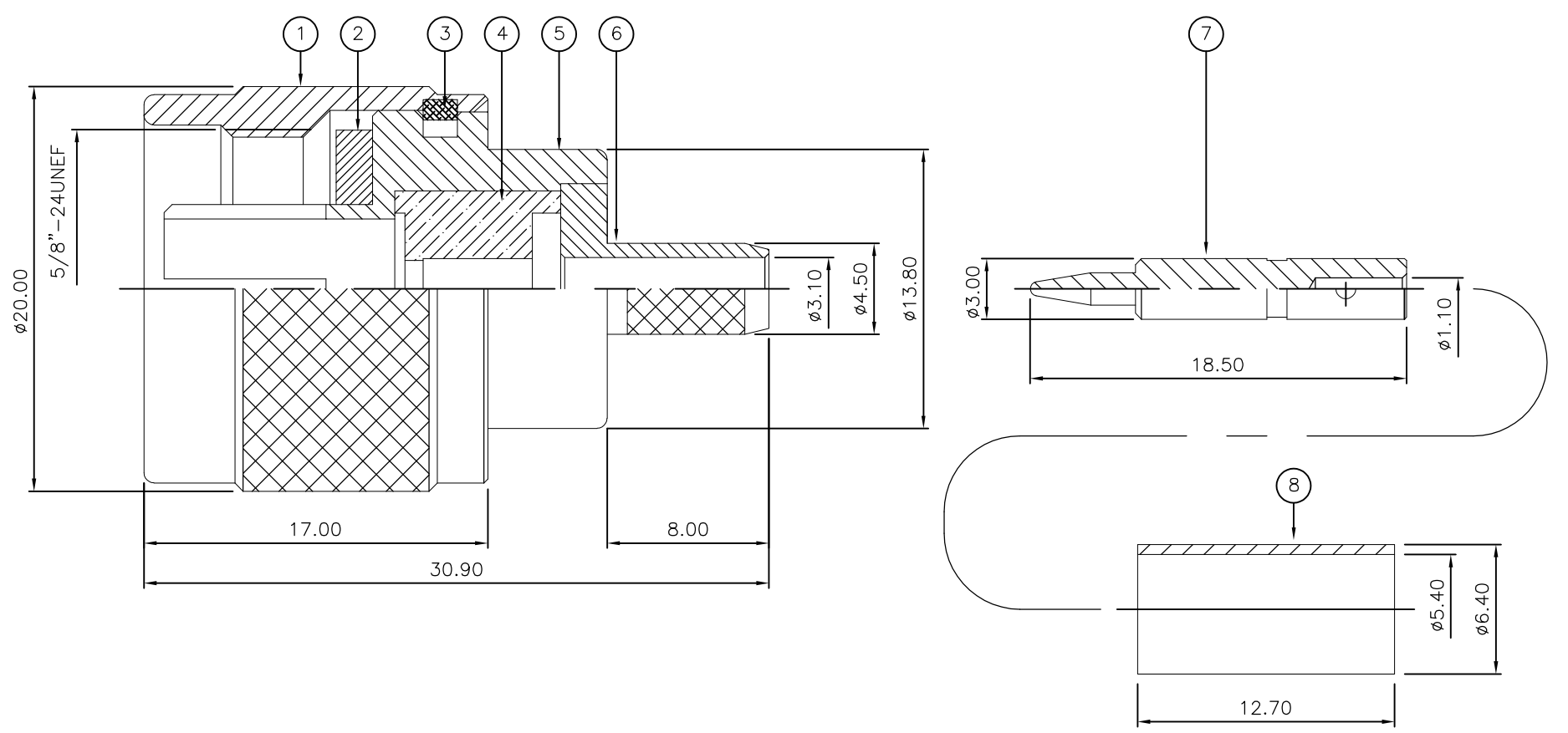

QTY	UNIT	MATERIAL	DESCRIPTION	ITEM
1	1	BRASS	FERRULE	8
1	1	BRASS	CONTACT	7
1	1	BRASS	CHASSIS	6
1	1	BRASS	BODY	5
1	1	PTFE	INSULATION	4
1	1	BRASS	CIRCLIP	3
1	1	SILICONE RUBBER	GASKET	2
1	1	BRASS	COUPLING NUT	1
6--0	1--0	MATERIAL	DESCRIPTION	ITEM

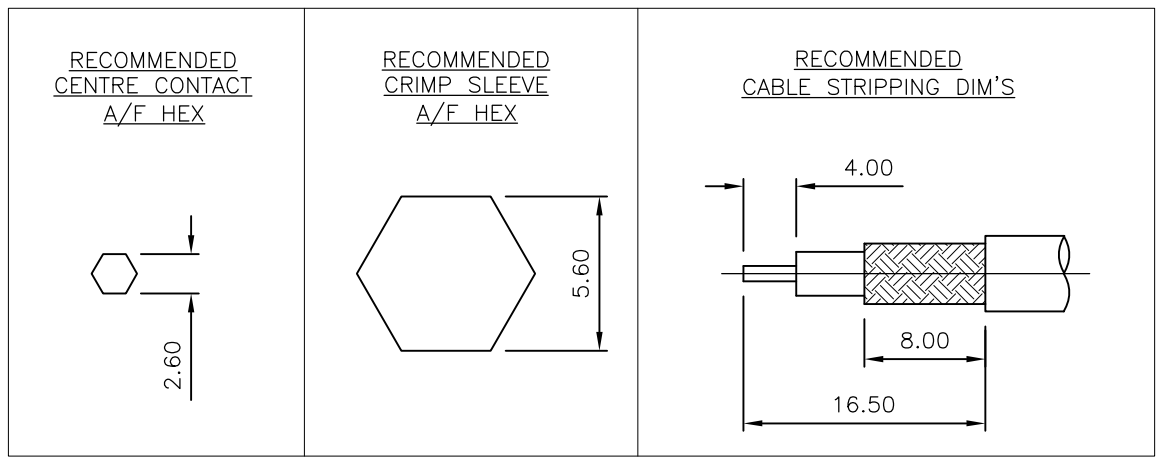

THIS DRAWING IS A CONTROLLED DOCUMENT.

DWN	RITA ZUO	18 Feb 2011
CHK	ANSON MA	18 Feb 2011
APVD	MARTIN YE	18 Feb 2011
PRODUCT SPEC		
APPLICATION SPEC		
WEIGHT		

NAME: Tyco Electronics Corporation, Shanghai P.R.China 200233

TYPE 'N' STRAIGHT PLUG CRIMP 50 OHM RG58C/U, 141A/U, URM43, 76, KX 15

SIZE	CAGE CODE	DRAWING NO	RESTRICTED TO
A3	00779	C-1337631	-

CUSTOMER DRAWING SCALE: NTS SHEET: 1 OF 1 REV: E