

# GIGABIT ETHERNET 850NM MULTIMODE SFP TRANSCEIVERS WITH DIGITAL DIAGNOSTICS

TRPUG1ESXx000E2G



## Product Description

The TRPUG1ESX-E2G fiber optic transceiver with integrated digital diagnostics monitoring functionality provides a quick and reliable interface for 1000BASE-SX Gigabit Ethernet applications. The diagnostic functions, alarm and warning features as described in the Multi-Source Agreement (MSA) document, SFF-8472 (Rev.9.5), are provided via an I<sup>2</sup>C serial interface.

The module satisfies Class 1 Laser Safety requirements in accordance with the U.S.FDA/CDRH and international IEC-60825 standards.

The transceiver connects to a standard 20-pad SFP connectors for hot plug capability. This allows the system designer to make configuration changes or maintenance by simply plugging in different types of transceivers without removing the power supply from the host system.

The transceiver has a bail-type latch, which offers an easy and convenient way to release the modules. The latch is compliant with the SFP MSA.

The transmitter and receiver DATA interfaces are AC-coupled internally. LV-TTL Transmitter Disable control input and Loss of Signal output interfaces are also provided.

The transceivers operate from a single +3.3V power supply over operating case temperature ranges of -5°C to +70°C (Commercial), -5°C to +85°C (Extended) or -40°C to +85°C (Industrial) . The housing is made of metal for EMI immunity.



## Features

- Compliant with IEEE 802.3ah Gigabit Ethernet 1000BASE-SX PMD Specifications
- Compliant with SFP MSA
- Digital Diagnostics through Serial Interface
- Internal Calibration for Digital Diagnostics
- 850nm Oxide VCSEL laser transmitter
- Up to 550m with 50/125µm MMF
- Up to 300m with 62.5/125µm MMF
- Eye Safe (Class 1 Laser Safety)
- Duplex LC Optical Interface
- Loss of Signal Output & TX Disable Input
- Wide Operating Case Temperature Option
- Hot-pluggable
- Single +3.3V Power Supply
- RoHS Compliant

## Absolute Maximum Ratings

Parameter		Symbol	Minimum	Maximum	Units
Storage Temperature Range		$T_{ST}$	- 40	+ 85	°C
Operating Case Temperature <sup>1</sup>	Commercial	$T_{OP}$	- 5	+ 70	°C
	Industrial		- 40	+ 85	°C
	Extended		- 5	+ 85	
Supply Voltage		$V_{CC}$	0	+ 3.47	V
Input Voltage		$V_{in}$	0	$V_{CC}$	V

<sup>1</sup> Measured on top side of SFP module at the front center vent hole of the cage.

**Transmitter Performance Characteristics** (Over Operating Case Temperature.  $V_{CC} = 3.13$  to  $3.47V$ )

Parameter	Symbol	Minimum	Typical	Maximum	Units
Operating Data Rate	$B$	-	1250	-	Mb/s
Optical Output Power <sup>1,2</sup>	$P_O$	-9.5	-	-3.0	dBm
Center Wavelength	$\lambda_C$	830	-	860	nm
Extinction Ratio	$ER$	9	-	-	dB
Spectral Width (FWHM)	$\Delta\lambda_{RMS}$	-	-	0.85	nm
Maximum with TX/Laser OFF	-	-	-	-30	dBm
Relative Intensity Noise	$RIN$	-	-	-117	dB/Hz
Deterministic Jitter	$DJ$	-	-	80	ps
Total Jitter	$T_J$	-	-	227	ps
Coupled Power Ratio	$CPR$	9	-	-	dB
Optical Output Eye	Compliant with applicable IEEE 802.3 specs				
<sup>1</sup> Average Optical Output Power is measured with 8B10B at 1250Mb/s					
<sup>2</sup> Measured average power coupled into either 50 $\mu$ m or 62.5 $\mu$ m multimode fiber.					

**Receiver Performance Characteristics** (Over Operating Case Temperature.  $V_{CC} = 3.13$  to  $3.47V$ )

Parameter	Symbol	Minimum	Typical	Maximum	Units
Operating Data Rate	$B$	-	1250	-	Mb/s
Minimum Sensitivity( $10^{-12}$ BER) <sup>1</sup>	$P_{min}$	-	-	-17.0	dBm
Maximum Input Optical Power ( $10^{-12}$ BER) <sup>1</sup>	$P_{max}$	0	-	-	dBm
LOS Thresholds	Increasing Light Input	$P_{los+}$	-	-17.0	dBm
	Decreasing Light Input	$P_{los-}$	-30.0	-	
LOS Hysteresis	-	0.5	-	-	dB
Wavelength of Operation	$\lambda$	770	-	860	nm
Optical return Loss	$ORL$	12	-	-	dB
Deterministic Jitter	$D_J$	-	-	170	ps
Total Jitter	$T_J$	-	-	266	ps
Electrical 3dB Upper Cutoff Frequency	-	-	-	1500	MHz
<sup>1</sup> Measured with 2 <sup>7</sup> -1 PRBS at 1250Mb/s at 850nm.					

**Laser Safety:** All transceivers are Class 1 Laser products per FDA/CDRH and IEC-60825 standards. They must be operated under specified operating conditions.

**Oplink Communications, LLC.**

This product complies with  
21 CFR 1040.10 and 1040.11  
**Meets Class 1 Laser Safety Requirements**

**Transmitter Electrical Characteristics** (Over Operating Case Temperature.  $V_{CC} = 3.13$  to  $3.47V$ )

Parameter	Symbol	Minimum	Typical	Maximum	Units	
Input differential impedance	$R_{in}$	80	100	120	ohm	
Single ended data input swing	$V_{in,pp}$	0.25	-	1.2	V	
TX Fault	Fault	$V_{OH}$	2.0	-	$V_{CC}$	V
	Normal	$V_{OL}$	$V_{ee}$	-	$V_{ee}+0.5$	V
TX Disable	Disable <sup>1</sup>	$V_{IH}$	2.0	-	$V_{CC}$	V
	Enable	$V_{IL}$	$V_{ee}$	-	$V_{ee}+0.8$	V

<sup>1</sup>Or open circuit.

**Receiver Electrical Characteristics** (Over Operating Case Temperature.  $V_{CC} = 3.13$  to  $3.47V$ )

Parameter	Symbol	Minimum	Typical	Maximum	Units	
Single ended data output swing <sup>1,2,3</sup>	$V_{out,pp}$	0.185	-	0.6	V	
LOS output voltage	Fault	$V_{OH}$	2.0	-	$V_{CC}$	V
	Normal	$V_{OL}$	$V_{ee}$	-	$V_{ee}+0.5$	V
MOD_DEF(0:2)	High	$V_H$	2.0	-	$V_{CC}$	V
	Low	$V_L$	$V_{ee}$	-	$V_{ee}+0.5$	V
Data output Rise/Fall Time(20% to 80%)	$t_r, t_f$	-	-	0.35	ns	

<sup>1</sup>Into 100 Ohm differential termination.  
<sup>2</sup>According to SFP-MSA (SFF committee INF-8074i)  
<sup>3</sup>Old requirement were 175/1000 mv. Changed to align with 8431 (to be plugged into EDC equipped 10G ports).

**Electrical Power Supply Characteristics** (Over Operating Case Temperature.  $V_{CC} = 3.13$  to  $3.47V$ )

Parameter	Symbol	Minimum	Typical	Maximum	Units
Supply Voltage	$V_{CC}$	3.13	3.30	3.47	V
Supply Current	$I_{CC}$	-	-	300	mA
Inrush Current <sup>1</sup>	$I_{in-rush}$	-	-	30	mA

<sup>1</sup> Hot plugging of the SFP transceiver module will result in an inrush current of no more than 30mA greater than the steady state value.

**Module Definition**

MOD_DEF(0) pin 6	MOD_DEF(1) pin 5	MOD_DEF(2) pin 4	Interpretation by Host
TTL LOW	SCL	SDA	Serial module definition protocol

### Electrical Pad Layout

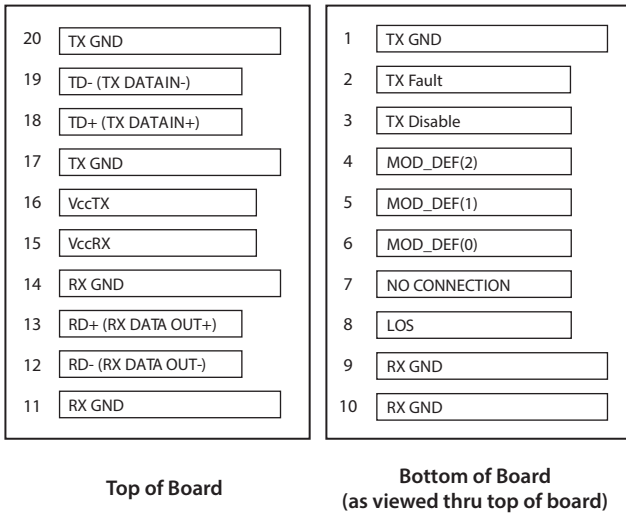

### Host Board Connector Pad Layout

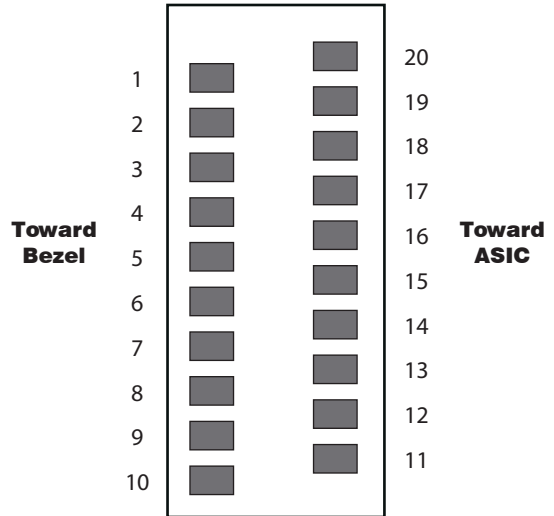

### Example of SFP host board schematic

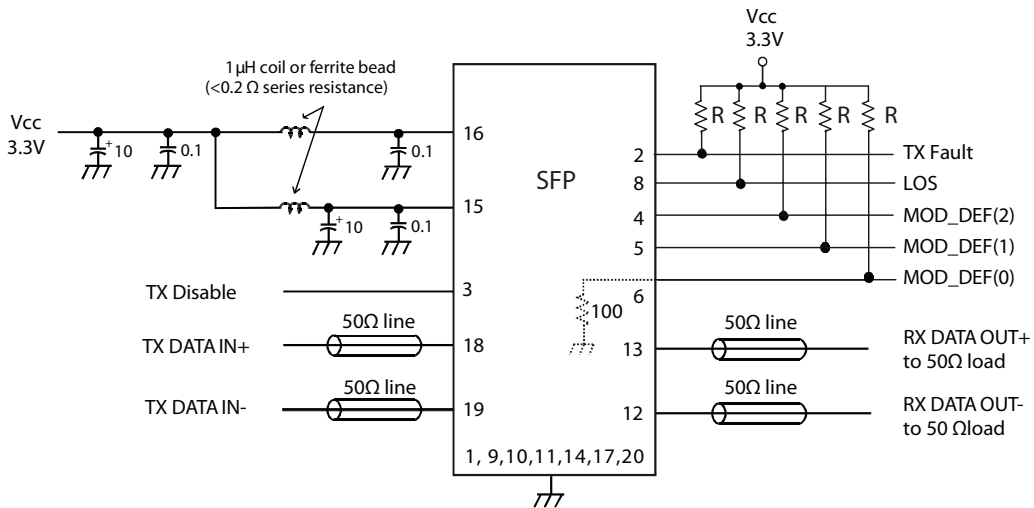

R: 4.7 to 10kΩ  
CAP Values in µF

### Application Notes

**Electrical interface:** All signal interfaces are compliant with the SFP MSA specification. The high speed DATA interface is differential AC-coupled internally with 0.1µF and can be directly connected to a 3.3V SERDES IC. All low speed control and sense output signals are open collector TTL compatible and should be pulled up with a 4.7-10kΩ resistor on the host board.

**Loss of Signal (LOS):** The Loss of Signal circuit monitors the level of the incoming optical signal and generates logic HIGH when an insufficient photocurrent is produced.

**TX\_Fault:** The output indicates LOW when the transmitter is operating normally and HIGH with a laser fault including laser end-of-life. TX Fault is an open collector/drain output

and should be pulled up with a 4.7 - 10kΩ resistor on the host board. TX Fault is non-latching (automatically deasserts when fault goes away).

**TX\_Disable:** When the TX Disable pin is at logic HIGH, the transmitter optical output is disabled.

**Serial Identification and Monitoring:** The module definition of SFP is indicated by the three module definition pins, MOD\_DEF(0), MOD\_DEF(1) and MOD\_DEF(2).

Upon power up, MOD\_DEF(1:2) appear as NC (no connection), and MOD\_DEF(0) is TTL LOW. When the host system detects this condition, it activates the serial protocol (standard two-wire I<sup>2</sup>C serial interface) and generates the serial clock signal

(SCL). The positive edge clocks data into the EEPROM segments of the SFP that are not write protected, and the negative edge clocks data from the SFP.

The serial data signal (SDA) is for serial data transfer. The host uses SDA in conjunction with SCL to mark the start and end of serial protocol activation. The supported monitoring functions are temperature, voltage, bias current, transmitter power, average receiver signal, all alarms and warnings, and software

monitoring of TX Fault/LOS. The device is internally calibrated.

The data transfer protocol and the details of the mandatory and vendor specific data structures are defined in SFP MSA, and SFF-8472, Rev. 9.5.

**Power supply and grounding:** The power supply line should be well-filtered. All 0.1µF power supply bypass capacitors should be as close to the transceiver module as possible.

### Mechanical Package

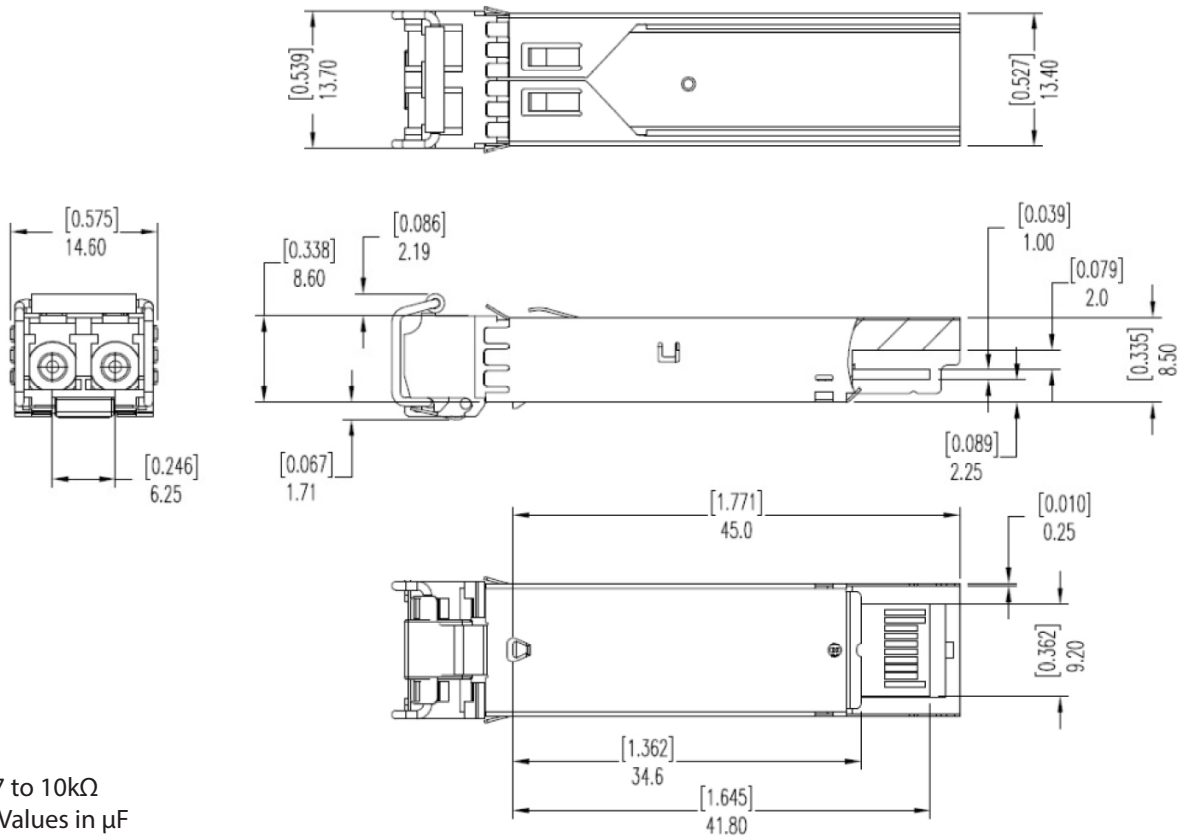

### Ordering Information

Oplink Part Number	Temperature	Nominal Wavelength	Distance	Latch Color
TRPUG1ESXE000E2G	- 5°C to +85°C	850nm	550m	Beige
TRPUG1ESXI000E2G	- 40°C to +85°C	850nm	550m	Beige
TRPUG1ESXC000E2G	- 5°C to +70°C	850nm	550m	Beige

<sup>1</sup>The indicated transmission distance is for guidelines only, not guaranteed, The exact distance is dependent on the fiber loss, connector and splice loss, and allocated system penalty. Longer distances can be supported if the optical link power budget is satisfied.

# Mouser Electronics

Authorized Distributor

Click to View Pricing, Inventory, Delivery & Lifecycle Information:

Molex:

[TRPUG1ESXC000E2G](#)