

THIS DOCUMENT IS THE PROPERTY OF  
KEYSTONE ELECTRONICS CORP. AND  
SHALL NOT BE REPRODUCED, DISTRIBUTED  
OR USED AS A BASIS FOR MANUFACTURE  
WITHOUT PRIOR WRITTEN PERMISSION  
FROM KEYSTONE ELECTRONICS CORP.

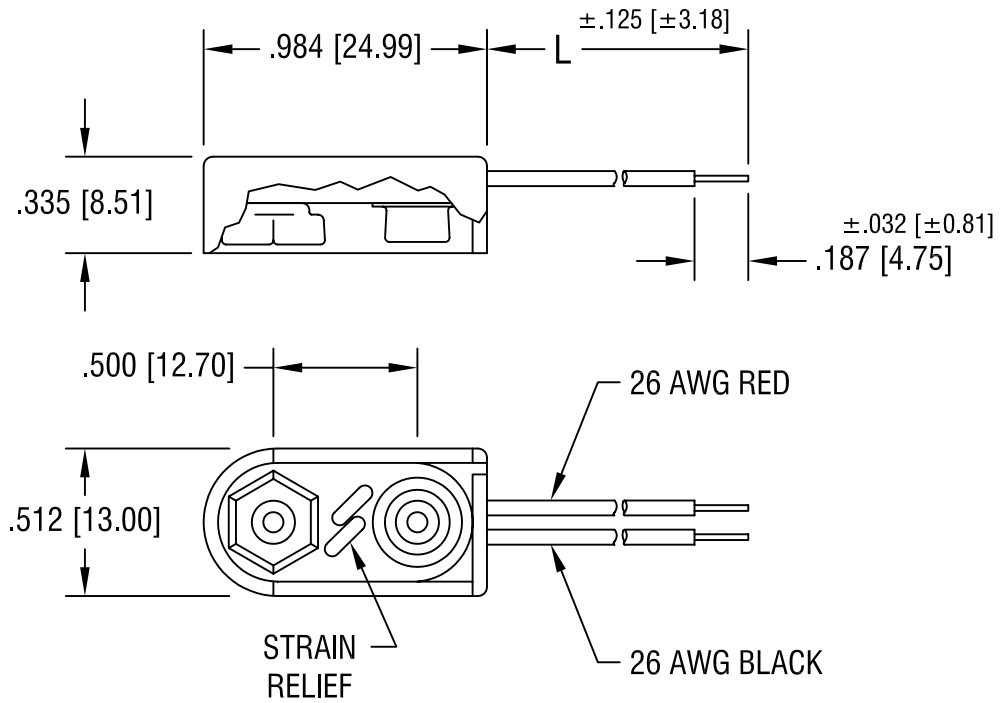

NOTES:

1. MAT'L -

WIRE: 26 AWG, 1007 UL/CSA APPROVED  
.052 [1.32] O.D. PVC INSULATION.  
RED WIRE CONNECTED TO FEMALE CONTACT;  
BLACK WIRE TO MALE CONTACT.

PART NO.	'L' DIM.
84-4	4.000 [101.60]
84-6	6.000 [152.40]
84-8	8.000 [203.20]

2. BASE:

MAT'L - ABS  
CONTACT:  
MAT'L - BRASS  
FINISH - NICKEL PLATE  
EYELET:  
MAT'L - BRASS

<b>KEYSTONE ELECTRONICS CORP.</b>			
ASTORIA, N.Y. 11105-2017			
PART NAME SHIELDED 9 VOLT 'I' TYPE BATTERY STRAP			
MATERIAL AS NOTED			
FINISH AS NOTED		DRN BY BOONE	DATE 5.2.96
		APP'D LN	SCALE 1.5X
TOLERANCES	INCH [MM]	CODE	DWG NO.
DECIMAL	±.010 [±0.25]	C/M	<b>84-</b>
ANGULAR	± 1°		
UNLESS OTHERWISE SPECIFIED			

DATE	DESCRIPTION	REV.
11.10.03	CHANGE AS PER ECN 03-082	B
4.1.98	CHANGE AS PER ECR 98-020	A