

THIS DRAWING IS UNPUBLISHED. RELEASED FOR PUBLICATION
 © COPYRIGHT - By - ALL RIGHTS RESERVED.

LOC	DIST	REVISIONS					
		P	LTR	DESCRIPTION	DATE	DWN	APVD
-	-			C1 OBSOLESCENCE OF P/N 2-160972-1	22JULY2013	SMT	RP

NOTES:

- 1 RANGE: Ø80 MAX.
- 2 MIN. TENSILE STRENGTH 130N.

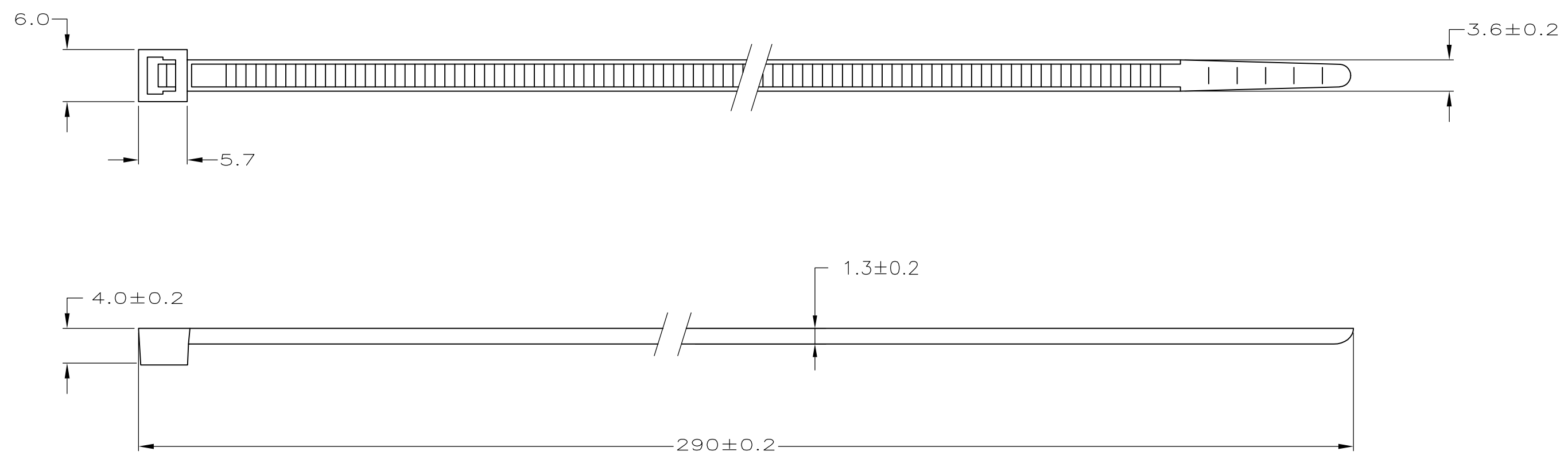

500	BLACK	POLYAMIDE 6.6	3-160972-2
500	NATURAL	POLYAMIDE 6.6	3-160972-1
100	BLACK	POLYAMIDE 6.6	2-160972-2
100	NATURAL	POLYAMIDE 6.6	2-160972-1
QTY	FINISH	MATERIAL	PARTNUMBER

THIS DRAWING IS A CONTROLLED DOCUMENT.		DWN J.V.D.HEIJDEN. 27-02-92	STE TE Connectivity													
DIMENSIONS: mm		CHK R.VOS.			NAME CABLE TY.											
TOLERANCES UNLESS OTHERWISE SPECIFIED:		APVD L.V.SOEST.	PRODUCT SPEC													
<table border="0"> <tr><td>0 PLC</td><td>± -</td></tr> <tr><td>1 PLC</td><td>± 0.4</td></tr> <tr><td>2 PLC</td><td>± -</td></tr> <tr><td>3 PLC</td><td>± -</td></tr> <tr><td>4 PLC</td><td>± -</td></tr> <tr><td>ANGLES</td><td>± -</td></tr> </table>		0 PLC	± -	1 PLC	± 0.4	2 PLC	± -	3 PLC	± -	4 PLC	± -	ANGLES	± -	APPLICATION SPEC		RESTRICTED TO
0 PLC	± -															
1 PLC	± 0.4															
2 PLC	± -															
3 PLC	± -															
4 PLC	± -															
ANGLES	± -															
MATERIAL SEE TABLE	FINISH SEE TABLE	WEIGHT -	SIZE A3	CAGE CODE 00779												
CUSTOMER DRAWING			DRAWING NO C-160972	RESTRICTED TO -												
SCALE NTS			SHEET 1 OF 1	REV C1												