

REVISIONS				
P.	LTN.	DESCRIPTION	DATE	APVD.
B		REV PER ECO 17-015175	11OCT2017	CT MOC

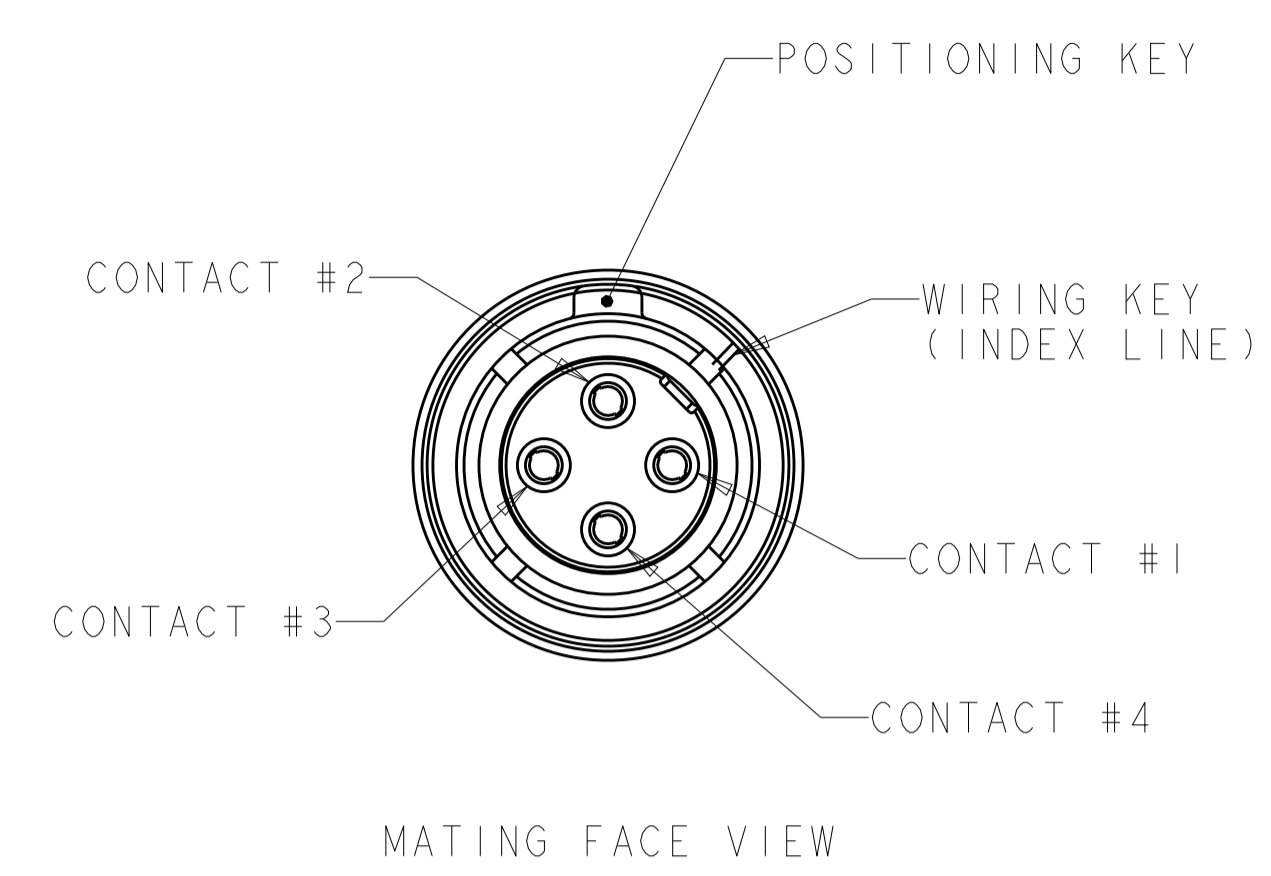

CONTACT CAVITY NUMBERING
 STANDARD CAVITY NUMBER ASSIGNMENT

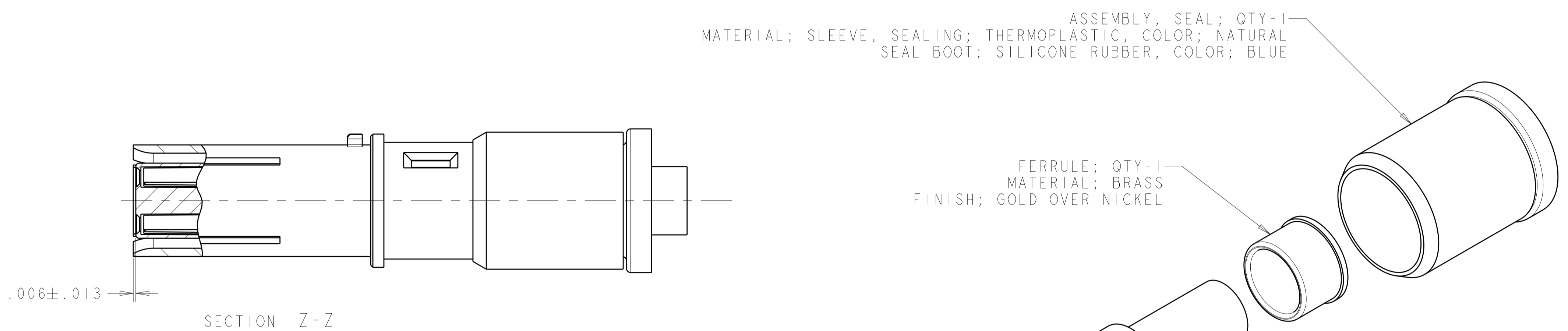
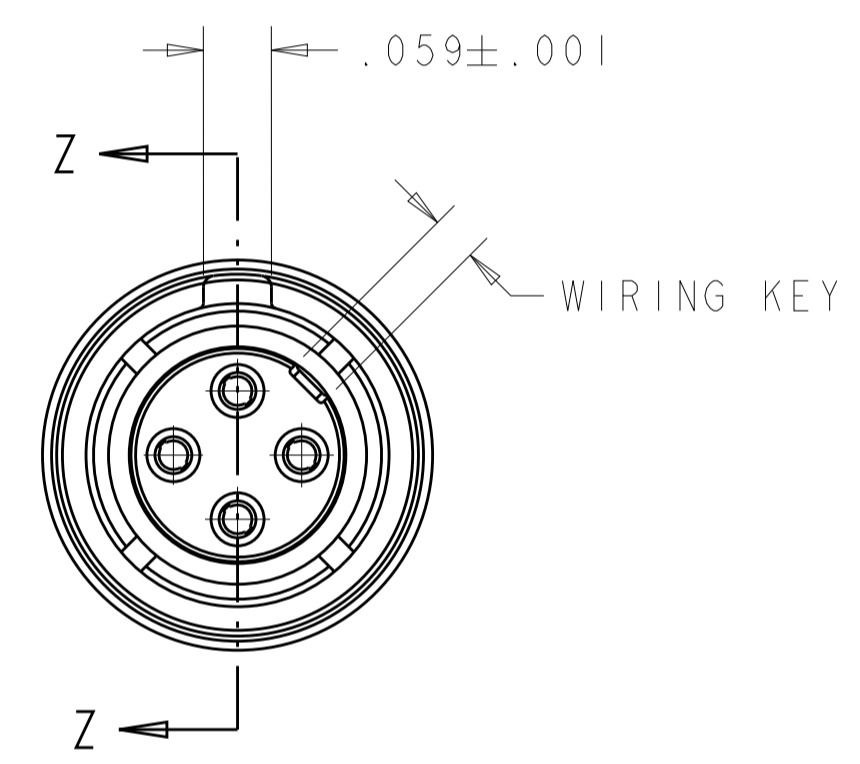
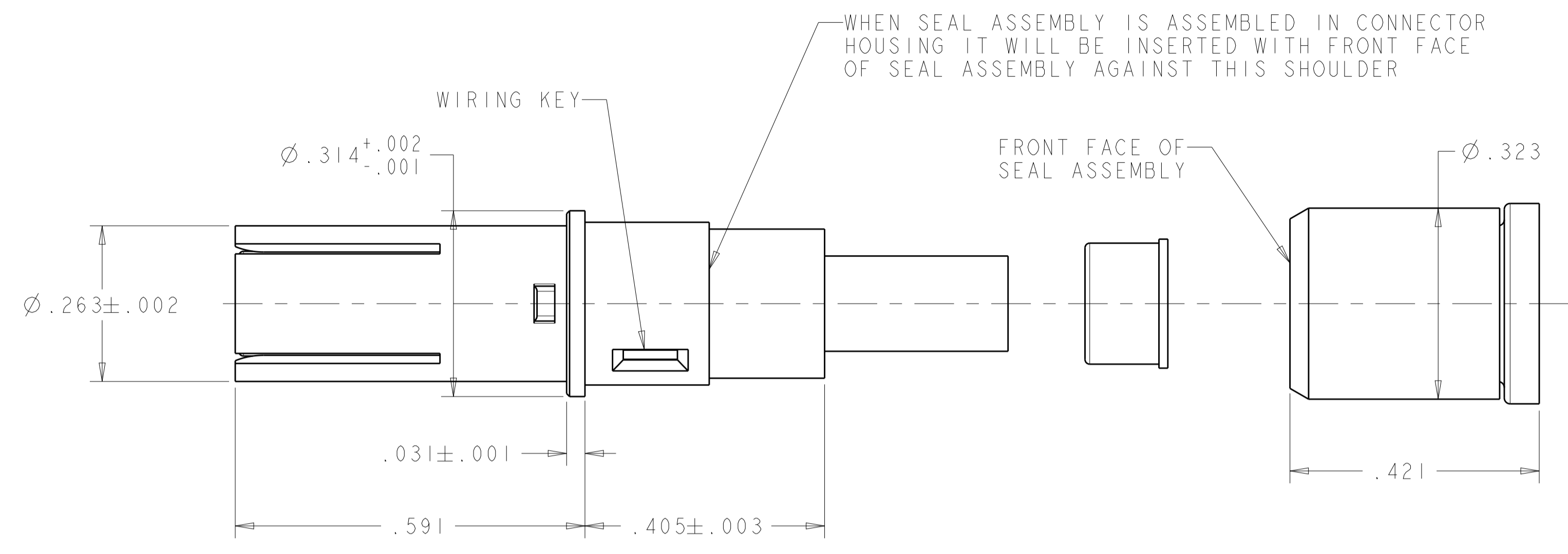

1. COMPONENTS ARE PACKAGED IN KIT FORM. CABLE MUST BE PURCHASED SEPARATELY.
2. ASSEMBLY PER APPLICATION SPECIFICATION 114-13123.
3. USE INSERTION-EXTRACTION TOOL 1738894-1.

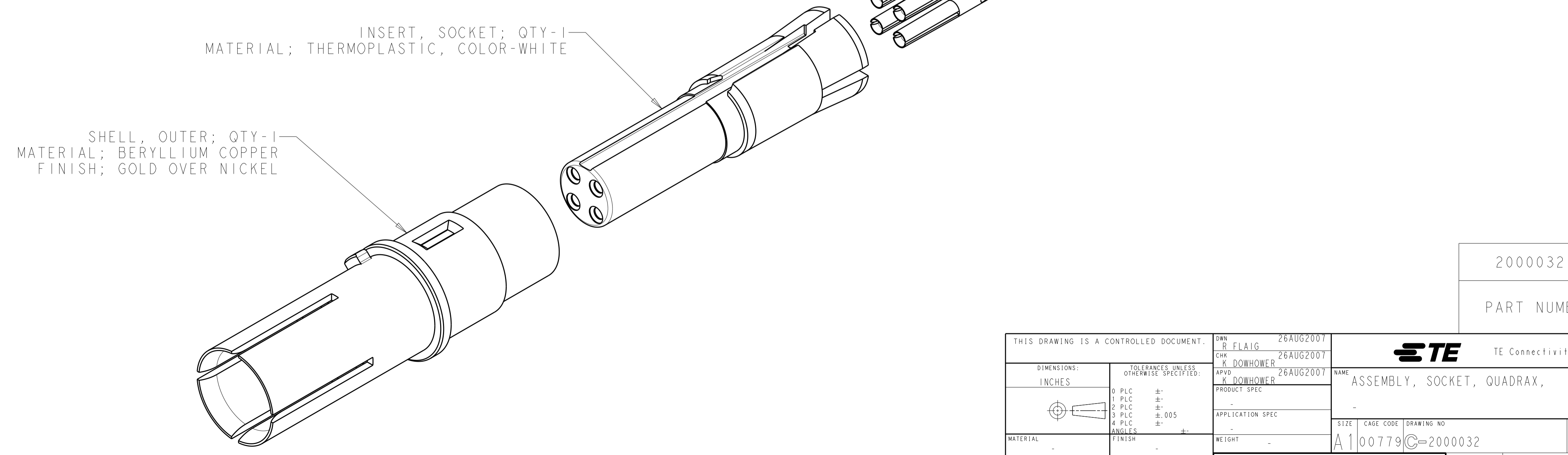

2000032-1
 PART NUMBER

THIS DRAWING IS A CONTROLLED DOCUMENT.		OWN R. FLAG 26AUG2007	TE Connectivity	
DIMENSIONS: INCHES		CHK K. DOWHOWER 26AUG2007	NAME ASSEMBLY, SOCKET, QUADRIX,	
TOLERANCES UNLESS OTHERWISE SPECIFIED:		APVD K. DOWHOWER 26AUG2007	PRODUCT SPEC	
0 PLC ±		APPLICATION SPEC	SIZE CAGE CODE DRAWING NO	
1 PLC ±		RESTRICTED TO	A100779C=2000032	
2 PLC ±		WEIGHT	SCALE 6:1 SHEET 1 OF 1 REV B	
3 PLC ±.005		CUSTOMER DRAWING		
4 PLC ±				
ANGLES ±				
FINISH				