

C-1-1105851-8

PASSMASS	ABMASS

PROJECT NO. -

USED ON HTS

# HTS - HAND TOOL FOR HN.D, HE/HA AND HVT CONTACTS 0,14 - 4,0 mm<sup>2</sup>

THIS DRAWING IS A CONTROLLED DOCUMENT FOR THE MANUFACTURING AND THE CONTROLLING ENGINEERING ORGANIZATION AND SHOULD BE CONTACTED FOR THE LATEST REVISION.

DIESES ZEICHNUNGSDOKUMENT WIRD DURCH AMP INCORPORATED KONTROLLIERT. AENDERUNGEN, DIE DEM TECHNISCHEN FORTSCHRITTSSTANDEN SIND VORBEHALTEN. DEN JEWELN LETZTLIETZTEN AENDERUNGSSTAND ERFAHREN SIE AUF ANFRAGE.

THIS INFORMATION IS CONFIDENTIAL AND IS DISCLOSED TO YOU BY YOU TO OTHER THAN AMP PERSONNEL WITHOUT WRITTEN AUTHORIZATION FROM AMP INCORPORATED, © - 2002 AMP

Querschnittgröße Wire Size mm <sup>2</sup>	Kontakttyp und TE P/N Contact type and TE P/N		
	HN.D	HE/HA	HVT
0,13 - 0,40			6-1105300-1 6-1105300-2 6-1105301-1 6-1105301-2
0,14		6-1105100-1 6-1105101-1	
0,14 - 0,37	1-1105050-1 1-1105050-2 1-1105051-1 1-1105051-2		
0,5	2-1105050-1 2-1105050-2 2-1105051-1 2-1105051-2	1-1105100-1 1-1105100-2 1-1105101-1 1-1105101-2	1-1105300-1 1-1105300-2 1-1105301-1 1-1105301-2
0,75 - 1,0	3-1105050-1 3-1105050-2 3-1105051-1 3-1105051-2	2-1105100-1 2-1105100-2 2-1105101-1 2-1105101-2	2-1105300-1 2-1105300-2 2-1105301-1 2-1105301-2
1,5	4-1105050-1 4-1105050-2 4-1105051-1 4-1105051-2	3-1105100-1 3-1105100-2 3-1105101-1 3-1105101-2	3-1105300-1 3-1105300-2 3-1105301-1 3-1105301-2
2,5	5-1105050-1 5-1105050-2 5-1105051-1 5-1105051-2	4-1105100-1 4-1105100-2 4-1105101-1 4-1105101-2	4-1105300-1 4-1105300-2 4-1105301-1 4-1105301-2
4,0		5-1105100-1 5-1105100-2 5-1105101-1 5-1105101-2	5-1105300-1 5-1105300-2 5-1105301-1 5-1105301-2

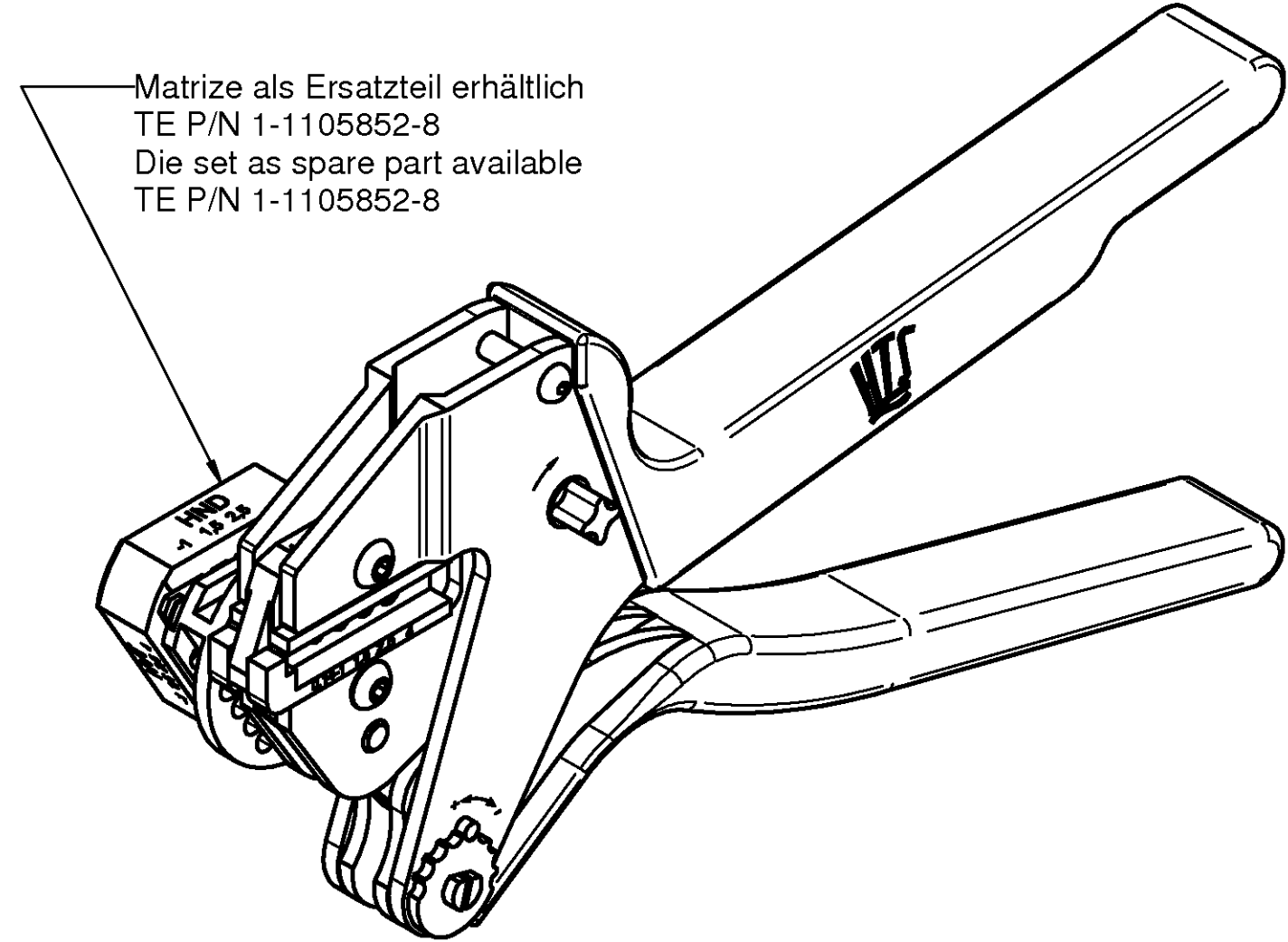

Handzange mit Matrize zusammengebaut und mit Bedienungsanleitung 411-18501 im Karton verpackt  
Hand Tool assembled with die set and packed in a cardboard with instruction sheet 411-18501

FREI-MASSTOLERANZEN NACH DIN 7168 (WERTE IN mm)							
1) ABWEICHEND VON DIN 7168 2) LÄNGE DES KÜRZEREN SOHNKELS							
NENNMASS- BEREICH 1)	ÜBER	0,5	3	6	30	120	400
BIS	3	6	30	120	400	1000	
LÄNGEN- ABMASSE	MITTEL	±0,1	±0,1	±0,2	±0,3	±0,5	±0,8
MASSE							
RADIEN U. FASEN		±0,2	±0,5	±1	±2	±4	±4
WINKELABMASSE 1) 2)		±1'	±1'	±30'	±20'	±10'	±5'

TEIL IM BEREICH X... MIT PN-STRICH-NR. (-1 WIE GEZ.), REVISION-STAND UND LIEFERANTENS YMBOL GEKENNZEICHNET							
PART TO BE MARKED WITH PN-DASH NO. (-1 AS SHOWN), REV. STATUS AND VENDORS MARK IN AREA X...							
OBERFLÄCHENVERGLEICHSTABELLE		BOHRG- OHNE ANGABE					
DIN3141	Rz	6,3	1,6	0,4	0,1	12,5	
R <sub>a</sub> in µm		✓	✓	✓	✓	✓	
DIN ISO 1302		✓	✓	✓	✓	✓	
ALLE UNBEMASSTE KANTEN 0,2x45° ENTGRÄTET REMOVE BURRS, BREAK SHARP EDGES 0,2x45°		HOLE NOT SPEC					

LOC	AI	DIST	P	LTR	REVISION RECORD	DATE	DWN	APVD

FINISH	-
DIMENSIONS:	mm
TOLERANCES UNLESS OTHERWISE SPECIFIED:	n. ISO 2768 n. ISO 2768 n. DIN 16901
ANGLES:	
SURFACE TEXTURE:	

DWN	23.09.2008 P. Demmer
CHK	23.09.2008 Ch. Witt
APVD	23.09.2008 Ch. Witt
NAME	HTS - HAND TOOL FOR HN.D, HE/HA AND HVT CONTACTS HTS - Handzange für HN.D, HE/HA und HVT Kontakte
SCALE	1:1
SIZE	A3
DRAWING NO	C-1-1105851-8

MATERIAL	-	Gewicht / Weight in Kg	0,935
HEAT TREAT	-		
Tyco Electronics 64625 Bensheim (Germany)			
SHEET	1	OF	1
REV	A		

8

7

6

5

4

3

2

1