

PART NUMBER DEVELOPMENT

EXAMPLE: TG70 - XX

BASIC PART NO _____

STRAP LENGTH 3 _____

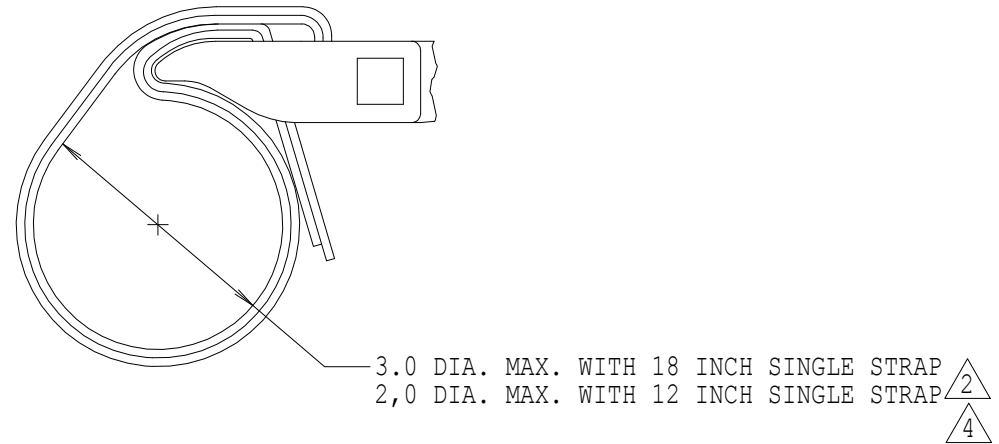
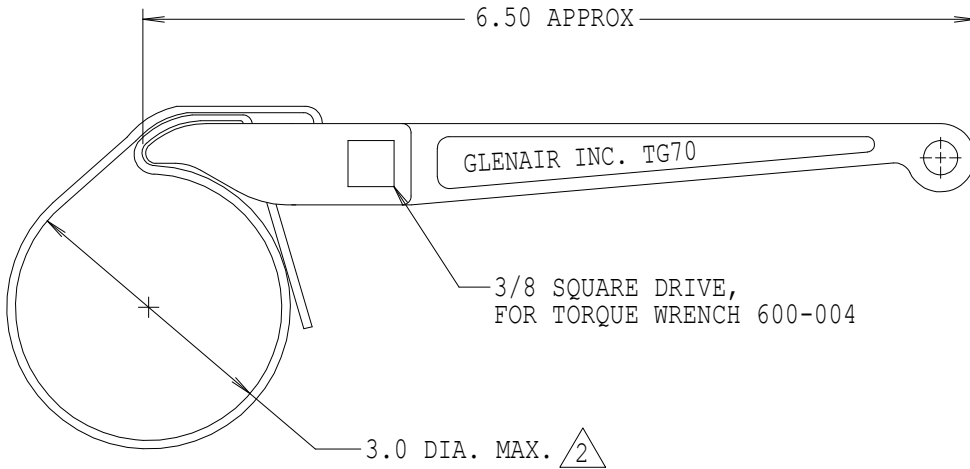

LENGTH AVAILABLE: -12, -18, -24, -36 ONLY
(STANDARD LENGTH IS 12 INCHES,
OMIT DASH NO FOR STANDARD)

REVISIONS			
SYM.	DESCRIPTION	DATE	APPROVED
A	REVISED PER DCN 11597	02/16/95	T.L.
B	REVISED PER DCN 11719	03/24/95	T.L.
C	REVISED PER DCN 12038	10/05/95	T.L.
D	REVISED PER DCN 12310	03/01/96	T.L.
E	REVISED PER DCN 13176	05/07/97	T.L.
F	REVISED PER DCN 16088	04/18/00	T.L.
G	REVISED PER DCN 36913	10/11/10	T.L.
H	REVISED PER DCN 37028	10/22/10	T.L.
J	REVISED PER DCN 43809	09/27/12	T.L.



NOTES:

- ASSEMBLY IDENTIFIED WITH MANUFACTURER'S NAME AND P/N, SPACE PERMITTING.
- SEE G70515 FOR REPLACEMENT STRAP.
- STRAP AVAILABLE IN FOUR (4) LENGTHS ONLY 12 INCHES, 18 INCHES, 24 INCHES AND 36 INCHES, 1/2 INCH WIDE.
- DOUBLE WRAP AS SHOWN FOR HEAVY DUTY RANGE.
- MATERIAL/FINISH:
WRENCH HANDLE - AL ALLOY/NICKEL PLATE
WEDGE - CRES/PASSIVATE.
STRAP - IMPREGNATED FABRIC.

THIS COPYRIGHTED DOCUMENT IS THE PROPERTY OF GLENAIR, INC. AND IS FURNISHED ON THE CONDITION THAT IT IS NOT TO BE DISCLOSED, REPRODUCED IN WHOLE OR IN PART, OR USED TO SOLICIT QUOTATIONS FROM COMPETITIVE SOURCES, OR USED FOR MANUFACTURE BY ANYONE OTHER THAN GLENAIR, INC. WITHOUT WRITTEN PERMISSION FROM GLENAIR, INC. THE INFORMATION HEREIN HAS BEEN DEVELOPED AT GLENAIR'S EXPENSE AND MAY BE USED FOR ENGINEERING EVALUATION AND INCORPORATION INTO TECHNICAL SPECIFICATIONS AND OTHER DOCUMENTS WHICH SPECIFY PROCUREMENT OF PRODUCTS FROM GLENAIR, INC.			
UNLESS OTHERWISE SPECIFIED	DRAWN	T. LE	02/16/95
	CHECK	P.O.	02/16/95
	ENGR	P. OAKES	02/16/95
DIMENSIONS ARE IN INCHES	 APPROVED		
TOLERANCES:			
FRACTIONS ± 1/16			
DECIMALS .XX ± .03 .XXX ± .015			
ANGLES ± 2°	 APPROVED		
DO NOT SCALE THIS DRAWING			
B/F95-8943 P/C 600	RELEASE DATE	02/16/95	06324
	ORIGINAL RELEASE DATE	10/31/74	B
		SCALE	N/A
		WEIGHT	N/A
		SHEET	1 OF 1
		REV.	J

GLENAIR, INC. CAD 1995 ©
1211 AIR WAY ° GLENDALE, CALIF. 91201

WRENCH, STRAP, 1/2 INCH

CODE IDENT. NO. **06324** SIZE **B** **TG70** REV. **J**