

SPVQ6 Water-proof Type

Compact type with body size of 13.3×5.3×7mm



Detector

Slide

Push

Rotary

Power

Dual-in-line Package Type

General-purpose Type

Water-proof Type

Fast Switching Type

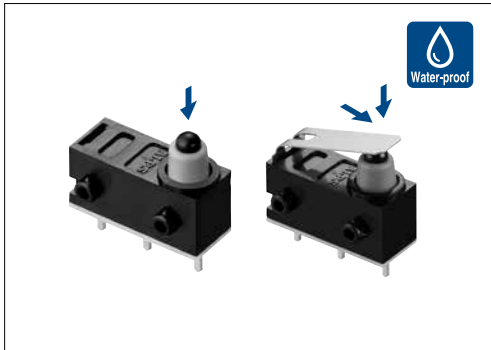

Typical Specifications

Items	Specifications		
	Standard type	With internal resistor type	
Rating (max.)/(min.) (Resistive load)	0.1A 12V DC / 50μA 5V DC		
Contact resistance (Initial / After operating life)	500mΩ max./1Ω max.		
電氣的出力	—	Respond individually	
Operating force	Push type	Actuator type	
	1±0.5N	3N max.	
Operating life	Without load	300,000cycles	
	With load	300,000cycles (0.1A 12V DC)	—

Product Line

Poles	Positions	Change over timing	Operating part shape	Terminal type	Main body form	Minimum order Unit (pcs.)		Product No.	Drawing No.
						Japan	Export		
1	2	Non shorting	Push	For PC board	Boss - right side	1,500	6,000	SPVQ640102	1
					Boss - left side			SPVQ640202	2
					Boss - right side			SPVQ630104	3
					Boss - left side			SPVQ630203	4
	Press fit		Without boss / Left bending	SPVQ6R *	5				

Note

This unit cannot be used in water (IP67 rating, except for terminal).

Packing Specifications

Tray

Number of packages (pcs.)		Export package measurements (mm)
1 case /Japan	1 case /export packing	
1,500	6,000	540×360×270

Dimensions

Unit:mm

No.	Style
1	

Dimensions

Unit:mm

No.	Style
2	
3	
4	

- Detector
- Slide
- Push
- Rotary
- Power
- Dual-in-line Package Type
- General-purpose Type
- Water-proof Type
- Fast Switching Type

SPVQ6 Water-proof Type

Detector

Slide

Push

Rotary

Power

Dual-in-line
Package Type

General-
purpose Type

Water-proof
Type

Fast Switching
Type

Dimensions

Unit:mm

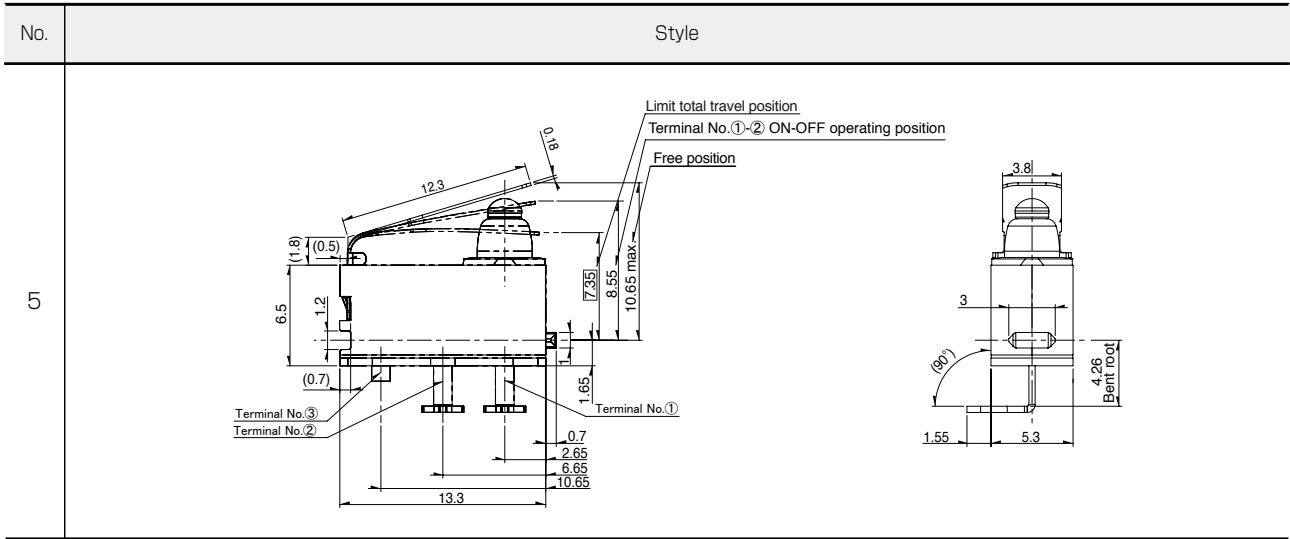

Recommended Unit Terminal Shape for Press-Fit Terminals (Normally Open)

Unit:mm



SPVQ6R*

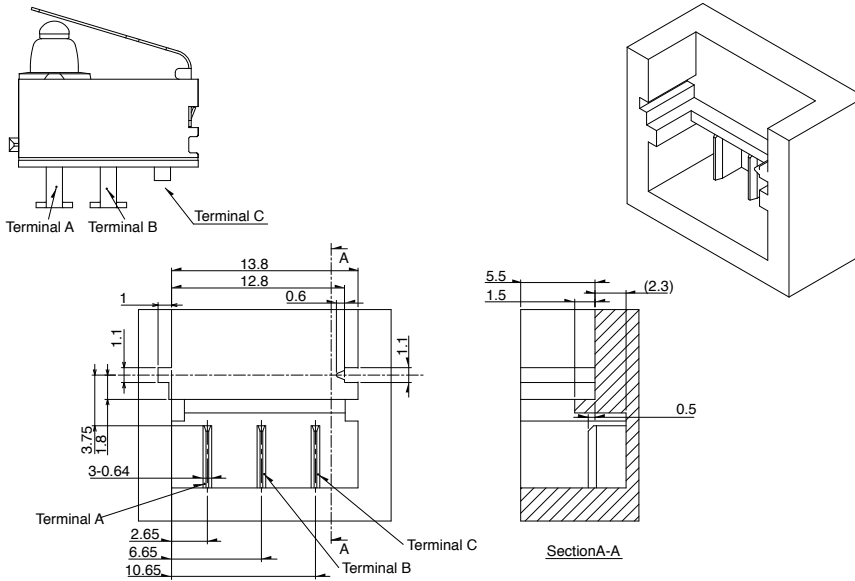



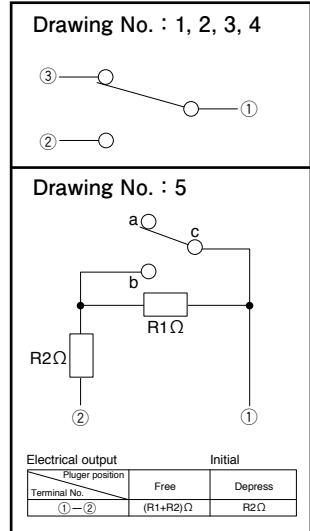



Circuit Diagram

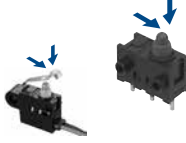

Detector Switches

List of Varieties

Series		Water-proof Type			
		SPVQ1	SPVQ3	SPVQ6	SPVQ7
Photo					
Operation type		One-way Two-way	Two-way	One-way Two-way	Two-way
Dimensions (mm)	W	13.3	13	13.3	14.7
	D	5.8		5.3	5.4
	H	8	8.35	7	6.7
Operating temperature range		-40°C to +85°C			
Automotive use		●	●	●	●
Life cycle (availability)					
Poles / Positions		1/2	1/1 1/2	1/2	1/1 1/2
Rating (max.) (Resistive load)		0.1A 12V DC			
Rating (min.) (Resistive load)		50μA 3V DC	50μA 5V DC		
Durability	Operating life without load	300,000cycles 1Ω max.			
	Operating life with load Rating (max.) (Resistive load)	300,000cycles 1Ω max.			
Electrical performance	Initial contact resistance	500mΩ max.			
	Insulation resistance	100MΩ min. 500V DC			
	Voltage proof	500V AC for 1minute			
Mechanical performance	Terminal strength	3N for 1minute	3N for 1minute (with terminal) Wire strength 30N for 1minute (with wire)	3N for 1minute	
	Actuator strength	20N			
Environmental performance	Cold	-40°C 500h			
	Dry heat	85°C 500h			
	Damp heat	60°C, 90 to 95% RH 500h			
Operation force		2N max. 5.9N max.	1±0.5N 3N max.		1±0.5N
Page		43	45	50	53

Detector Switches Soldering Conditions	66
Detector Switches Cautions	67

Note

- Indicates applicability to all products in the series.

Example of Reflow Soldering Condition

1. Heating method: Double heating method with infrared heater.
2. Temperature measurement: Thermocouple $\phi 0.1$ to 0.2 CA (K) or CC (T) at soldering portion (copper foil surface).
A heat resisting tape should be used for fixed measurement.
3. Temperature profile



Series (Reflow type)	A (°C) 3s max.	B (°C)	C (s)	D (°C)	E (°C)	F (s)
SPPB	250	230	40	180	150	120
SPVE	260		40			
SPVL						
SPVM						
SPVN						
SPVR						
SPVS						
SPVT						
SSCM						
SSCQ						
SPVQC	250					

Notes

1. The condition mentioned above is the temperature on the mounting surface of a PC board. There are cases where the PC board's temperature greatly differs from that of the switch, surface depending on the PC board's material, size, thickness, etc.
The above-stated conditions shall also apply to switch surface temperatures.
2. Soldering conditions differ depending on reflow soldering machines.
Prior verification of soldering condition is highly recommended.

Reference for Hand Soldering

Series	Soldering temperature	Soldering time
SPVS, SPVN, SPVT, SPVM, SPVR, SPVE, SSCQ, SSCM, SPVL, SSCT, SPVQC	350±5°C	3s max.
SPVQ1, SPVQ3, SPVQ6, SPVQ7, SPVQ8, SPVQ9, SSCN, SPVQA	300±10°C	3 + 1 / 0s
SPPB (Reflow)	300±5°C	5s max.
SSCF, SPPB (For Lead, Dip)	350±10°C	3 + 1 / 0s

Reference for Dip Soldering (For PC board terminal types)

Series	Items		Dip soldering	
	Preheating temperature	Preheating time	Soldering temperature	Duration of immersion
SSCT, SPVQ1, SPVQ3, SPVQ6, SPVQ7, SPVQ8, SPVQ9, SPVQA	100±10°C	60s max.	260±5°C	5±1s
SPPW8, SPPB	100°C max.	60s max.	255±5°C	5±1s
SSCF	—		260±5°C	5±1s