

THIS COPY IS PROVIDED ON A RESTRICTED BASIS AND IS NOT TO BE USED IN ANY WAY DETRIMENTAL TO THE INTERESTS OF PANDUIT CORP.

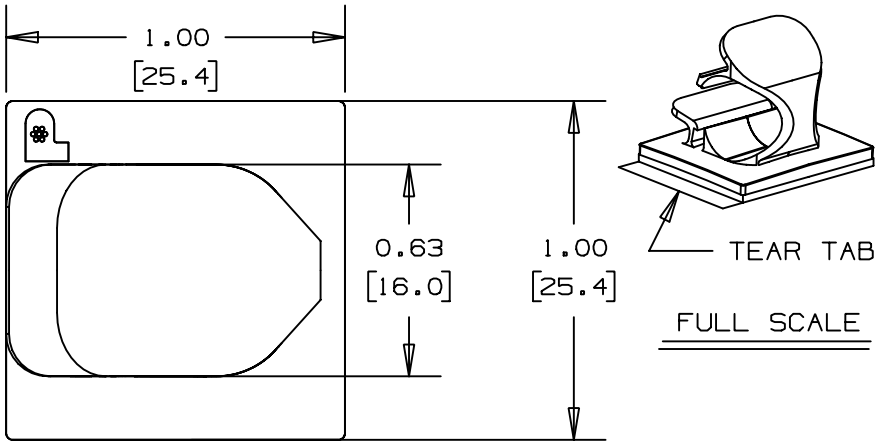

PANDUIT PART NUMBER*	MAXIMUM CABLE DIA. in. (mm)	WEIGHT lbs. (g)/100pcs
LWC38-A	0.37 (9.5)	0.64 (292)

**NOTES:**

- \*1) SEE CURRENT PRICE SHEET FOR PART NUMBER SUFFIX DESIGNATION, FOR PACKAGE SIZE.
- 2) MOUNT IS DESIGNED TO SUPPORT 0.50 lbs [227g] MAX WEIGHT ON A CLEAN DRY SMOOTH SURFACE.

- TO APPLY LATCHING WIRE CLIP:
1. REMOVE PROTECTIVE LINER
  2. PLACE IN DESIRED LOCATION
  3. APPLY PRESSURE TO TOP OF LATCHING WIRE CLIP

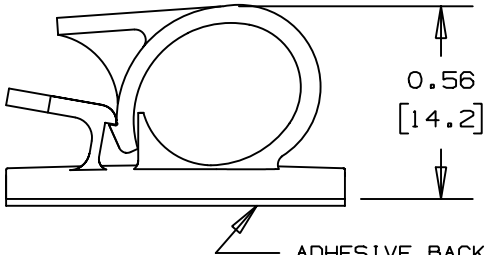

ADHESIVE BACKING: PRESSURE SENSITIVE FOAM 0.04 [1.0] THICK WITH PROTECTIVE LINER TO EXTEND BEYOND EDGE FORMING A TEAR TAB.

NO WARRANTY, EXPRESSED OR IMPLIED, IS MADE BY PANDUIT WITH RESPECT TO ADHESIVE BOND PERFORMANCE, AMONG OTHER THINGS, THE CONDITIONS UNDER WHICH THESE MOUNTS MAY BE APPLIED, AND/OR THE SURFACE TO WHICH THEY MAY BE APPLIED, ARE BEYOND PANDUIT'S CONTROL.

DIMENSIONS IN BRACKETS ARE METRIC [ mm ]

CAD FILENAME/LAYERS G00160BA\_PB\_LWC38A\_01

**PANDUIT** CORP. TINLEY PARK, ILLINOIS

LWC38-A, LATCHING WIRE CLIP

UNLESS OTHERWISE SPECIFIED, DIMENSIONAL TOLERANCES ARE:  
 (.X) ±0.05 (1.3) (.XX) ±0.010 (0.25)  
 (.XX) ±0.02 (0.5) ANGLES ± 5°

UNLESS OTHERWISE SPECIFIED, ALL DIMENSIONS ARE GIVEN IN INCHES, THIRD ANGLE PROJECTION.

DRAWN BY JRL  
 DATE 11-11-93  
 CHK'D

MAT'L: NYLON 6/6

SCALE 2X

DRAWING NO.

G00160BA

DWG SIZE A

REV	DATE	BY	CHK	DESCRIPTION	ECN	R	CUST	SUP
I	1-7-98	CGSM		CHANGED NOTE 3 ON APPLICATION INSTR.	G00160BA	I		
R	11-11-93	JRL		INITIAL RELEASE	G00160BA	R		