

## Posistor® For Circuit Protection

### 1. Part Numbering (Part Number)

PT   GL   04   AS   100   K   2N51   B0  
 Product ID   Series   Dimensions   Temperature Characteristics   Resistance   Resistance Tolerance   Individual Specifications   Packaging

### 2. Ratings

Bulk Part Number	Max. voltage	*1 Resistance Value at +25°C	*2 Max. Current	*3 Hold current			*4 Trip current			Dimensions (mm)		
				+60°C	+25°C	-10°C	D	H	dia			
PTGL04AS100K2N51B0	30V rms.	10ohm±10%	1.5A	122mA	154mA	205mA	240mA	4.5	9.5	0.5		
PTGL04AS100K2N51A0		10ohm ±10%	2.0A	167mA	212mA	282mA	330mA	4.5	9.5	0.6		
PTGL05AS3R9K2B51B0		3.9ohm±10%	3.5A	269mA	340mA	452mA	530mA	5.5	10.5	0.6		
PTGL05AS3R9K2B51A0		2.7ohm±10%	4.5A	336mA	425mA	565mA	663mA	7.3	12.3	0.6		
PTGL07AS2R7K2B51B0		1.8ohm±10%	5.0A	420mA	532mA	708mA	829mA	7.3	12.3	0.6		
PTGL07AS2R7K2B51A0		1.2ohm±10%	6.0A	556mA	704mA	936mA	1097mA	9.3	14.3	0.6		
PTGL07AS1R8K2B51B0		0.8ohm±10%	7.0A	685mA	867mA	1153mA	1352mA	11.5	16.5	0.6		
PTGL07AS1R8K2B51A0												
PTGL09AS1R2K2B51B0												
PTGL09AS1R2K2B51A0												
PTGL12AS0R8K2B51B0												
PTGL12AS0R8K2B51A0												

- \*1 The resist. value is measured at a point of max. 2mm from the end of lead crimp.
- \*2 Shows the maximum current value which may be repeatedly introduced into Posistor when the circuit runs abnormally.
- \*3 Shows the maximum current value which may be continuously introduced into Posistor when the circuit runs normally at each ambient temperature.
- \*4 Shows the minimum current value which flows the circuit when Posistor protects it from over load at each ambient temperature.

### 3. Dimensions (mm)

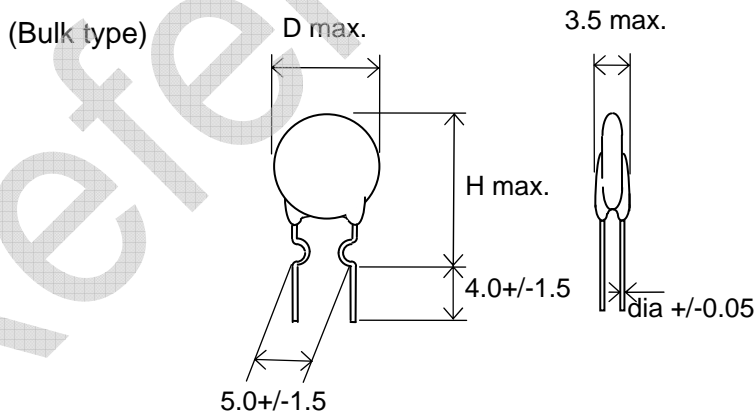

(Taping type : Shown in Taping specification.)

#### Note)

Some part of resin covering lead wire of Posistor may come off by some outside shock on the root of lead wire, but Posistor can be used normally for electrical and reliability characteristics.



AS-026'

## Taping Specification

### 1. Dimensions of Taping



Item	Code	Dimensions	Note
Pitch of Component	P	12.7	Tolerance is determined by $\Delta S$
Pitch of Sprocket Hole	P0	$12.7 \pm 0.3$	
Lead Spacing	F	$5.0^{+0.8}_{-0.3}$	
Length from Hole Center to Component	P2	$6.35 \pm 1.3$	Deviation in the feeding direction
Length from Hole Center to Lead	P1	$3.85 \pm 0.8$	
Body Diameter	D	Refer to "2.Dimensions"	
Body Thickness	T	Refer to "2.Dimensions"	
Deviation along Tape. Left or Right	$\Delta S$	$0 \pm 1.5$	Including the inclination caused by lead bending.
Carrier Tape Width	W	$18.0 \pm 0.5$	
Position of Sprocket Hole	W1	$9.0^{+0.5}_{-0.75}$	Deviation of tape width.
Lead Distance between Reference and Bottom Planes	H0	$16.0 \pm 1.0$	
	H2	6.0 max.	
Overflow of Lead	l	-0.5 ~ +1.0	
Diameter of Sprocket Hole	D0	$4.0 \pm 0.2$	
Lead Diameter	d	Refer to "2.Dimensions"	
Total Tape Thickness	t1	$0.6 \pm 0.3$	t2 = 2.0 max.
Deviation across Tape	$\Delta h1, \Delta h2$	1.5 max	
Portion to cut in Case of Defect	L	$11.0^{+0}_{-2.0}$	
Hold Down Tape Width	W0	11.0 min.	
Hold Down Tape Position	W2	4.0 max.	
Coating Extension on Lead	e	Up to the center of crimp	

2. Splicing way of tape

2.1 Cohesive power of tape is over 2.94N at test condition as below figure.



Fig.1

2.2 Splicing of tape

a. When base tape is spliced :



- Base tape shall be spliced by cellophane tape
- Total tape thickness shall be less than 1.05mm

b. When adhesive tape is spliced :



- Adhesive tape shall be spliced with overlapping.
- Total tape thickness shall be less than 1.05mm

c. When both tape are spliced at a time :



Splicing tape  
(Base and adhesive tapes  
are inserted in a splicing  
tape.)

(in mm)

### 2.3 Packing specification (Ammo Pack).

The tape with Posistor is folded each 25 pitches and packed in zigzag into a packing case, when body of Posistor is piled on other body under it. Standard quantity in a case are 1500pcs..

#### The size of packing case



#### Packing way



When Posistor 's body is situated on your side, adhesive tape is situated the upside.

## Notice for use

 **Caution**

1. This product is designed for application which is used under ordinary environment.(room temperature, normal humidity, normal pressure) Do not expose this to the following environments, because all these factor can deteriorate the characteristic of this and can cause failure or burn out.
  - (1) Corrosive gas or deoxidizing gas (Cl<sub>2</sub>, H<sub>2</sub>S, NH<sub>3</sub>, SO<sub>x</sub>, NO<sub>x</sub> etc.)
  - (2) Volatile, flammable gas
  - (3) Dusty place
  - (4) Place in a vacuum, reducing or putting pressure
  - (5) Place in splashed water, or high humidity and dewing place
  - (6) Salt water, oil, chemical liquid and solvent
  - (7) Vibratile place
  - (8) Other place equivalent to the above
  
2. Limitation of Applications  
Please contact us before using our products for the under-mentioned applications requiring especially high reliability in order to prevent defects which might directly cause damage to other party's life body or property(listed below).
  - (1)Aircraft equipment (2)Aerospace equipment (3)Undersea equipment (4)Power plant control equipment
  - (5)Medical equipment (6)Transportation equipment(automobiles, trains, ships, etc.)
  - (7)Traffic signal equipment (8)Disaster prevention / Crime prevention equipment
  - (9)Data-processing equipment (10)Applications of similar complexity or with reliability requirements comparable to the applications listed in the above.
  
3. Be sure to provide an appropriate fail-safe function on your product to prevent a second damage that may be caused by the abnormal function or the failure of our product.

**Notice**

1. Do not apply abnormal voltage/current exceeding the specified maximum value. Because they may deteriorate or destroy PTC element.
2. Use this product within the specified temperature. A higher temperature may deteriorate the characteristic or material.
3. When this product is operated, temperature of some area may be over 100°C to 160°C. Please make sure that surrounding parts and inserting material can withstand the temperature. If the surrounding part and material is kept under such condition, they may be deteriorated or may produce harmful gas(Cl<sub>2</sub>, H<sub>2</sub>S, NH<sub>3</sub>, SO<sub>x</sub>, NO<sub>x</sub> etc.). And, such harmful gas may deteriorate the element.
4. The resin coating of this product is not for insulating purpose. Keep an adequate insulating distance to surrounding components.
5. This product does not have waterproof construction. A splashed water may cause failure mode such as deterioration of characteristic or current leak.  
So, Do NOT apply cleaning to immerse it into water or any solvent.
6. If you coat this product by resin, please evaluate the quality of this product before you use it.  
The stress of force which is caused by coating materials or heat cycles may cause failure mode such as deterioration of characteristic or current leak in worst case.
7. This product is using the solder of 221+/-5 °C of melting points, in order to connect ceramics with a lead wire. Do not heat up a terminal area of this product over 180 °C.
8. The ceramic element of this product is fragile, and care must be taken not to load a excessive pressforce or not to give a shock at handling. Such forces may cause cracking or chipping.

9. Do not apply an excessive force to the lead. Otherwise, it may cause break off the junction between lead and element, or may crack element. Therefore, hold of element side lead wire is recommended when lead wire is bent or cut.
10. When the lead of this product is soldered, pay attention as follows to avoid the decline of element characteristic or break down the element.
  - (1) Use Rosin type flux or non-activated flux(the content of chlorine shall be less than 0.2%)
  - (2) Do not dip the body into flux. (Flux shall be coated to lead wire only for soldering.)
  - (3) The pre-heat up should be conducted without melting the soldering of this product.
11. Do not apply tensile force or separating force to lead wire at soldering.
12. Do not touch the resin case by soldering iron. The soldering point shall be min. 5 mm away from the root of lead wire. Please solder the following conditions.
  - Iron Tip Temperature : 360 degree C max.
  - Soldering Time : 4 seconds max. / 1 terminal
  - Number of Soldering : 1
13. To keep solderability of product from declining, following storage condition is recommended.
  - (1) Storage condition Temperature : -10 to +40°C  
Humidity : less than 75%RH(not dewing condition)
  - (2) Term : Please use this product within 6 months after shipment by first-in and first-out stocking system.
  - (3) Handling after unpacking of the minimum package : Reseal it promptly or store it seal open inside a sealed container with a drying agent.
  - (4) Place : Do not store this product in corrosive gas(SO<sub>x</sub>,Cl etc) or under sun-light.