

AVERY DENNISON MARKETING SPECIFICATION

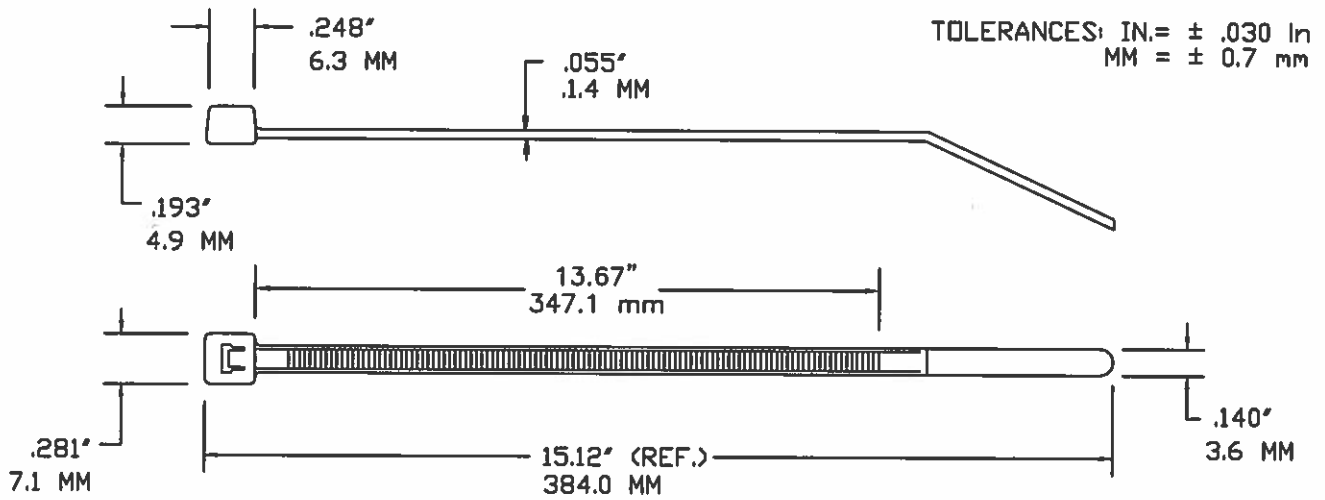

NOT TO SCALE

TENSILE STRENGTH:	40 LBS. / 18.1 KG. MINIMUM PER MIL-S-23190
MATERIAL:	NYLON 6/6 PER ASTM D4066
WEIGHT:	.06154 OZ. / 1.81 GRAMS
BUNDLE DIAMETER:	1/16" - 4
APPLICATION TOOL:	TOOL, HAND ADJUSTABLE, FOR PLASTIC TIE DOWN STRAP. AVERY DENNISON PART NUMBER 12001.
TOOL TENSION SETTING:	3-5
PACKAGED IN:	1000 PACKS IN SEALED BAGS (100 PACKS AVAILABLE)



FASTENER DIVISION
FITCHBURG, MA 01420 U.S.A.
TEL. 1-800-225-5913
MA. 978-353-8157

DESCRIPTION:

15" CABLE TIE, SLIM-LINE - NATURAL

APPROVAL:

Linda Boyle 5-3-2016

STOCK NO.

10335-0

REV

K