

DATA SHEET N° DS/177	PLOTTER SYSTEM PROTECTIVE SLIDE FOR EXTERNAL PANEL TAG	REL: 0 DATE: 11/01/99
---------------------------------------	---	--

DRAWING

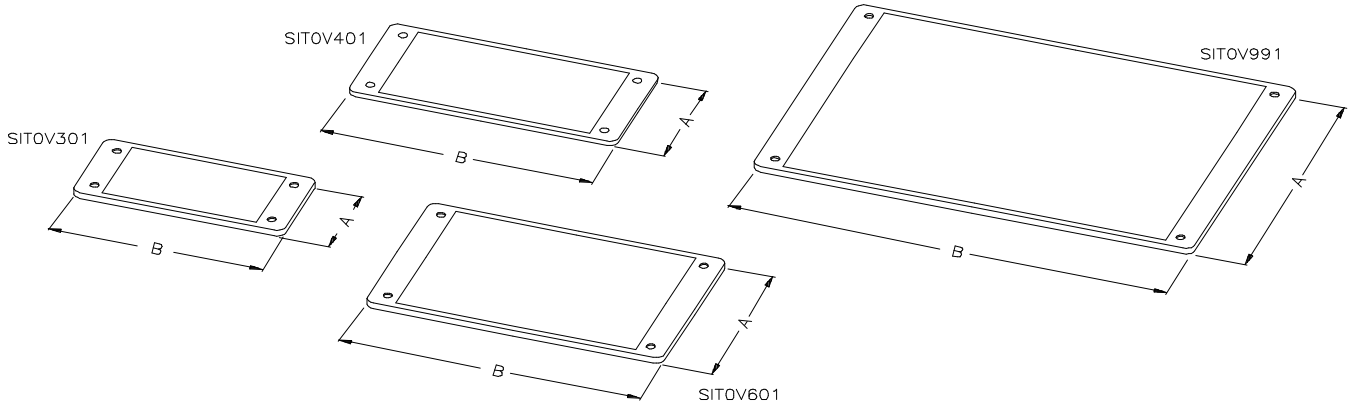

REFERENCE ITEMS

SIT0V301 - SIT0V301MC - SIT0V401 - SIT0V401MC - SIT0V601 - SIT0V601MC - SIT0V991 - SIT0V991MC

CHARACTERISTICS OF THE MATERIAL

TYPE OF MATERIAL	POLYCARBONATE, HALOGEN FREE
FIRE RESISTANCE	CLASS VO ACCORDING TO UL - 94
COLOUR	TRANSPARENT
TEMPERATURE RANGE	-50 ÷ +120 °C
TOXIC MATERIAL ABSENCE OF	PCB, PCT, PBB, PBDO, VC (MAX. 1 PPM)
RESISTANCE TO WATER	☺
RESISTANCE TO OILS	☺
RESISTANCE TO DUST	☺
RESISTANCE TO ACIDS	☺

ITEMS	DIMENSIONS (A x B) mm.	MAX DIAMETER RIVET	Q.TY PER PACK (PCS)
SIT0V301	34 x 74	3 mm	10
SIT0V301MC	34 x 74	3 mm	240
SIT0V401	44 x 93,8	3 mm	10
SIT0V401MC	44 x 93,8	3 mm	120
SIT0V601	63,8 x 103,7	3 mm	10
SIT0V601MC	63,8 x 103,7	3 mm	120
SIT0V991	103,7x153,5	3 mm	10
SIT0V991MC	103,7x153,5	3 mm	44

NOTES:

Document Number	CHECK.,APPROV.	DATE:	SUBJECT MATTER OF REVISION	PAG:
78-8127-9008-3			NEW EMISSION	1 of 1

LEGENDA:

- ☺ = Guaranteed characteristic
- ☹ = To prove case by case