

## Handy Resistor Simulates RTD Temperature Outputs, Such as PT-100 and PT-1000

### FEATURES AND BENEFITS

- **Temperature coefficient of resistance (TCR):**  
–55°C to +125°C, 25°C ref.
  - RTD simulator (C): ±2 ppm/°C typical (see Table 1)
  - RTD simulator (K): ±1 ppm/°C typical (see Table 1)
- Resistance tolerance: to ±0.005% (50 ppm)
- Available temperature range (<-200°C to >+800°C), order your RTD Simulator by desired simulated temperature or resistance value.
- Load life stability: ±0.005% after 2,000 hrs at rated power at 70°C
- Power rating: to 0.6 W at +70°C
- Resistance range: 10 Ω to 5 kΩ (for higher or lower values, please contact us)
- VFR resistors are not restricted to standard values; specific “as required” values can be supplied at no extra cost or delivery (e.g., 1K01234 vs. 1k)
- **Electrostatic discharge (ESD): at least to 25 kV**
- Non-inductive, non-capacitive design
- Rise time: 1 ns effectively no ringing
- Current noise: 0.010 μV<sub>RMS</sub>/V of applied voltage (<-40 dB)
- Thermal EMF: 0.05 μV/°C
- Voltage coefficient: <0.1 ppm/V
- **Each RTD Simulator based on the Bulk Metal® Foil technology comes with a built-in climate control (CC) feature.**

### INTRODUCTION

#### Calibrate all your RTD inputs

The new foil RTD Simulators can simulate RTDs in all types of instruments, such as transmitters, controllers, and data acquisition, process control, and lab equipment, etc. Each resistance unit comes with certification and printed temperature on the resistor itself. Connect an RTD and instantly read the temperature indicated on the resistor.

#### Better than a decade box—faster, easier, and much less expensive

This new RTD Simulator is a complete compact simulator for checkout and calibration of all RTD instruments in the field, shop, or control room.

The long-term stability conditions of the RTD Simulator are regulated with respect to temperature and humidity.

#### Note

\* This datasheet provides information about parts that are RoHS-compliant and/or parts that are non-RoHS-compliant. For example, parts with lead (Pb) alloy-plated terminations are not RoHS compliant. Please see the information/tables in this datasheet for details.

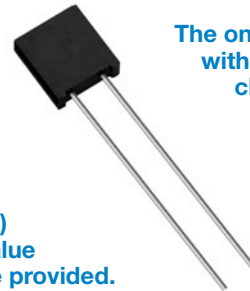

The only resistor  
with internal  
climate isolation.

$R = f(T)$   
Any value  
can be provided.



Pb-free  
Available  
**RoHS\***  
COMPLIANT

Available from our Express Hub  
[www.resistors4u.com](http://www.resistors4u.com)

### CLIMATE CONTROL (CC)

Two predictable and opposing physical phenomena within the composite structure of the resistive alloy and its substrate are keys to the low absolute TCR capability of a Bulk Metal Foil resistor:

- Resistivity of the resistive alloy changes directly with temperature in free air (resistance of the foil increases when temperature increases.)
- The Coefficient of Thermal Expansion (CTE) of the alloy and the substrate to which the foil alloy is cemented are different, resulting in a compressive stress on the resistive alloy when temperature increases (resistance of the foil decreases due to compression caused by the temperature increases).

The TCR of the foil resistor is achieved by matching two opposing effects—the inherent increase in resistance due to temperature increase vs. the compression—related decrease in resistance due to that same temperature increase. The two effects occur simultaneously, resulting in an unusually low, predictable, repeatable, and controllable TCR.

Due to VPG’s Bulk Metal Foil resistor design, this TCR characteristic is accomplished automatically, without selection, and regardless of the resistance value or the date of manufacture—even if years apart!

**Table 1 – Resistance vs. TCR**  
(-55°C to +125°C, +25°C Ref.)

RTD SIMULATOR	RESISTANCE VALUE (Ω)	NOMINAL TCR AND MAX. SPREAD (ppm/°C)
RTD-K	80 to <5k	±1 ±2.5
RTD-C	80 to <5k	±2 ±2.5
RTD-K	50 to <80	±1 ±3.5
RTD-C		±2 ±3.5
RTD-K	10 to <50	±1 ±4.5
RTD-C		±2 ±4.5

(1) C refers to C Foil Alloy; K refers to the K Foil Alloy.

**Figure 1 – Trimming to Values**  
(conceptual illustration)

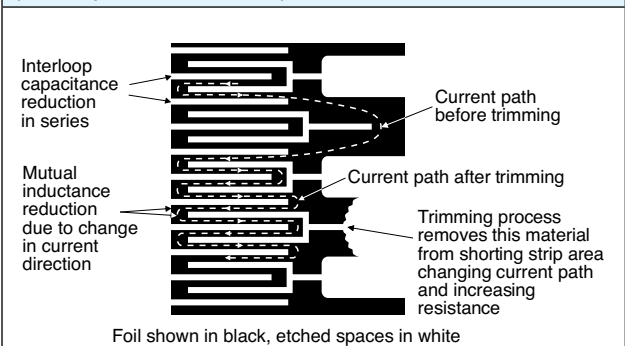

**Note**

To acquire a precision resistance value, the Bulk Metal Foil chip is trimmed by selectively removing built-in “shorting bars.” To increase the resistance in known increments, marked areas are cut, producing progressively smaller increases in resistance. This method reduces the effect of “hot spots” and improves the long-term stability of VFR resistors.

**Figure 2 – Standard Imprinting and Dimensions**

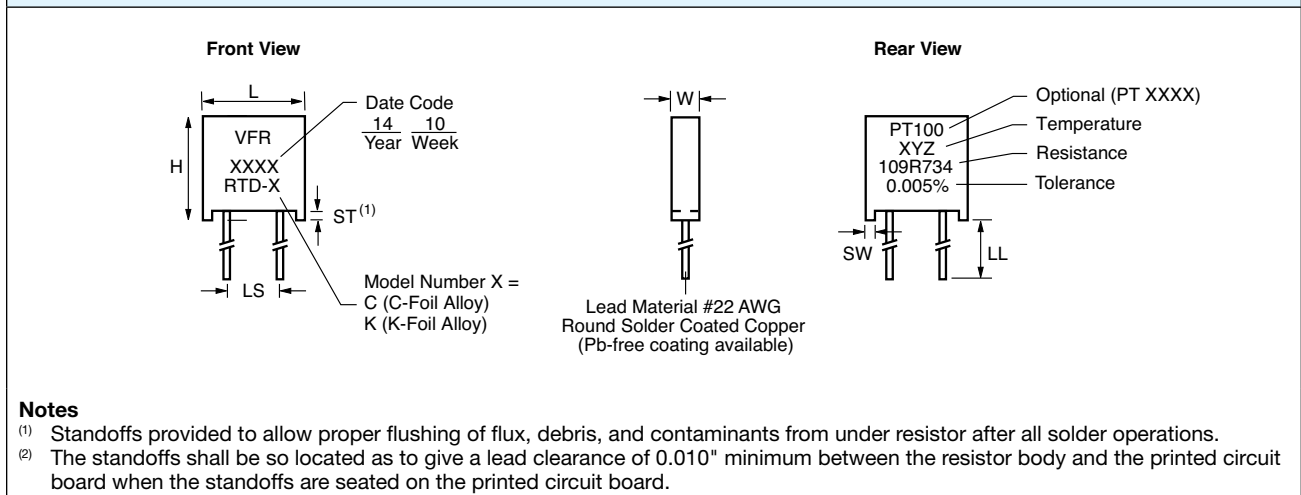

**Table 2 – Model Selection**

MODEL NUMBER	MAXIMUM WORKING VOLTAGE	AVERAGE WEIGHT IN GRAMS	DIMENSIONS		TIGHTEST TOLERANCE VS. LOWEST RESISTANCE VALUE
			INCHES	mm	
RTD-C (RTD-J) <sup>(1)</sup>	300	0.6	W: 0.105 ±0.010	2.67 ±0.25	0.005% / 50 Ω 0.01% / 25 Ω 0.02% / 12 Ω 0.05% / 10 Ω
RTD-K (RTD-L) <sup>(1)</sup>			L: 0.300 ±0.010	7.62 ±0.25	
	H: 0.326 ±0.010	8.28 ±0.25			
	ST: 0.010 min.	0.254 min.			
	SW: 0.040 ±0.005	1.02 ±0.13			
	LL: 1.000 ±0.125	25.4 ±3.18			
	LS: 0.150 ±0.005	3.81 ±0.13			

(1) 0.200" (5.08 mm) lead spacing available—specify RTD-J for RTD-C and RTD-L for RTD-K.

**Table 3—Environmental Performance Comparison**

GROUP/PARAMETER		MIL-PRF-55182 CHAR J	RTD SIMULATOR	
			MAXIMUM $\Delta R$	TYPICAL $\Delta R$
<b>Test Group I</b> Thermal shock, 5 x (-65°C to +150°C) Short time overload, 6.25 x rated power, 5 seconds		$\pm 0.2\%$ $\pm 0.2\%$	$\pm 0.01\%$ (100 ppm) $\pm 0.01\%$ (100 ppm)	$\pm 0.002\%$ (20 ppm) $\pm 0.003\%$ (30 ppm)
<b>Test Group II</b> Low temperature storage (24 h at -65°C) Low temperature operation (45 min, rated power at -65°C) Terminal strength		$\pm 0.15\%$ $\pm 0.15\%$ $\pm 0.2\%$	$\pm 0.01\%$ (100 ppm) $\pm 0.01\%$ (100 ppm) $\pm 0.01\%$ (100 ppm)	$\pm 0.002\%$ (20 ppm) $\pm 0.002\%$ (20 ppm) $\pm 0.002\%$ (20 ppm)
<b>Test Group III</b> Dielectric Withstanding Voltage (DWV) Resistance to solder heat Moisture resistance		$\pm 0.15\%$ $\pm 0.1\%$ $\pm 0.4\%$	$\pm 0.01\%$ (100 ppm) $\pm 0.01\%$ (100 ppm) $\pm 0.05\%$ (500 ppm)	$\pm 0.002\%$ (20 ppm) $\pm 0.005\%$ (50 ppm) $\pm 0.01\%$ (100 ppm)
<b>Test Group IV</b> Shock Vibration		$\pm 0.2\%$ $\pm 0.2\%$	$\pm 0.01\%$ (100 ppm) $\pm 0.01\%$ (100 ppm)	$\pm 0.002\%$ (20 ppm) $\pm 0.002\%$ (20 ppm)
<b>Test Group V</b> Life test at 0.3 W/+125°C	2000 h 10 000 h	$\pm 0.5\%$ $\pm 2.0\%$	$\pm 0.015\%$ (150 ppm) $\pm 0.05\%$ (500 ppm)	$\pm 0.01\%$ (100 ppm) $\pm 0.03\%$ (300 ppm)
<b>Test Group Va</b> Life test at 0.6 W (2 x rated power)/+70°C, 2000 h		$\pm 0.5\%$	$\pm 0.015\%$ (150 ppm)	$\pm 0.01\%$ (100 ppm)
<b>Test Group VI</b> High temperature exposure (2000 h at +175°C)		$\pm 2.0\%$	$\pm 0.1\%$ (1000 ppm)	$\pm 0.05\%$ (500 ppm)
<b>Test Group VII</b> Voltage coefficient		5 ppm/V	<0.1 ppm/V	<0.1 ppm/V

**Figure 3—Part Number Information <sup>(1)</sup>**

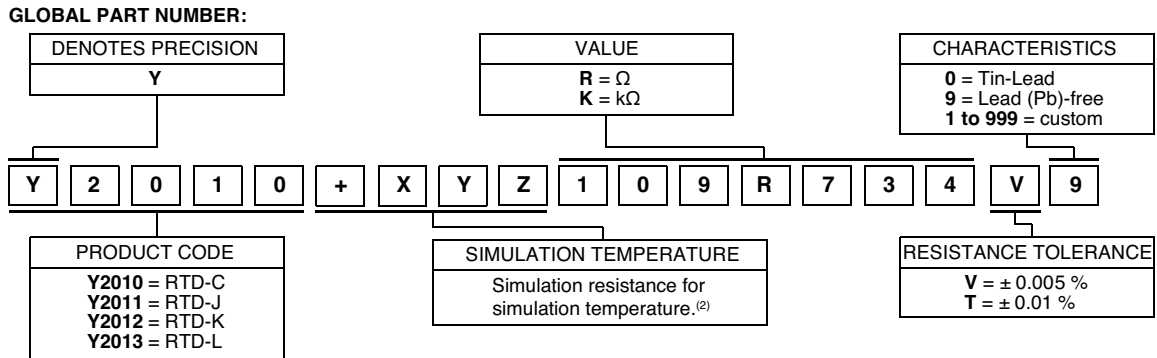

TYPE: RTD-C  
 TEMPERATURE:  $\pm XYZ^{\circ}\text{C}$   
 VALUE: 109.734  $\Omega$   
 ABSOLUTE TOLERANCE:  $\pm 0.005\%$   
 TERMINATION: lead (Pb)-free  
 PACKAGING: bulk pack (standard)

**PART NUMBER: RTD-C T  $\pm XYZ^{\circ}\text{C}$  109.734 V**

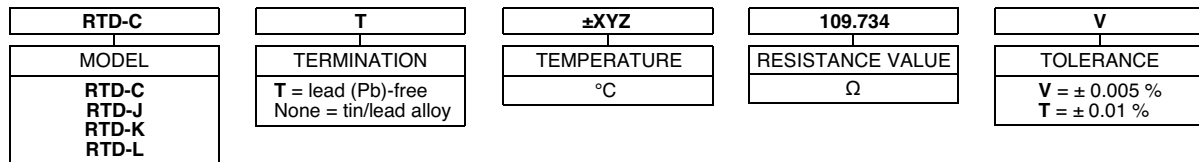

**Note**

- (1) Resistors will be supplied per value specified on the order. Temperature listed is for reference only; customer's Resistance vs Temperature correlation not verified by VFR.
- (2) Please specify type of RTD and simulation temperature.

**ORDER TODAY VIA LOCALLY-MADE EXPRESS HUB ([www.resistors4u.com](http://www.resistors4u.com))**

While global marketing and distribution make most resistors available throughout most of the world, Express Hubs give customers the choice of central-factory sourcing or local manufacturing—ideal for urgently needed high-precision resistors in prototype quantities at any resistance value or tolerance. Any value from 10  $\Omega$  and tolerances of 0.005% in small quantities are available in five working days or less. Take a closer look at each of our Express Hubs, where craftsmanship is always on display.



## Disclaimer

ALL PRODUCTS, PRODUCT SPECIFICATIONS AND DATA ARE SUBJECT TO CHANGE WITHOUT NOTICE.

Vishay Precision Group, Inc., its affiliates, agents, and employees, and all persons acting on its or their behalf (collectively, "VPG"), disclaim any and all liability for any errors, inaccuracies or incompleteness contained herein or in any other disclosure relating to any product.

The product specifications do not expand or otherwise modify VPG's terms and conditions of purchase, including but not limited to, the warranty expressed therein.

VPG makes no warranty, representation or guarantee other than as set forth in the terms and conditions of purchase. **To the maximum extent permitted by applicable law, VPG disclaims (i) any and all liability arising out of the application or use of any product, (ii) any and all liability, including without limitation special, consequential or incidental damages, and (iii) any and all implied warranties, including warranties of fitness for particular purpose, non-infringement and merchantability.**

Information provided in datasheets and/or specifications may vary from actual results in different applications and performance may vary over time. Statements regarding the suitability of products for certain types of applications are based on VPG's knowledge of typical requirements that are often placed on VPG products. It is the customer's responsibility to validate that a particular product with the properties described in the product specification is suitable for use in a particular application. You should ensure you have the current version of the relevant information by contacting VPG prior to performing installation or use of the product, such as on our website at [vpgsensors.com](http://vpgsensors.com).

No license, express, implied, or otherwise, to any intellectual property rights is granted by this document, or by any conduct of VPG.

The products shown herein are not designed for use in life-saving or life-sustaining applications unless otherwise expressly indicated. Customers using or selling VPG products not expressly indicated for use in such applications do so entirely at their own risk and agree to fully indemnify VPG for any damages arising or resulting from such use or sale. Please contact authorized VPG personnel to obtain written terms and conditions regarding products designed for such applications.

Product names and markings noted herein may be trademarks of their respective owners.

Copyright Vishay Precision Group, Inc., 2014. All rights reserved.