

REVISIONS					
REV	ECO	DESCRIPTION	DATE	BY	APPR
A1	-	TECHNICAL DATA SHEET RELEASE	12-MAY-14	KMM	RFC

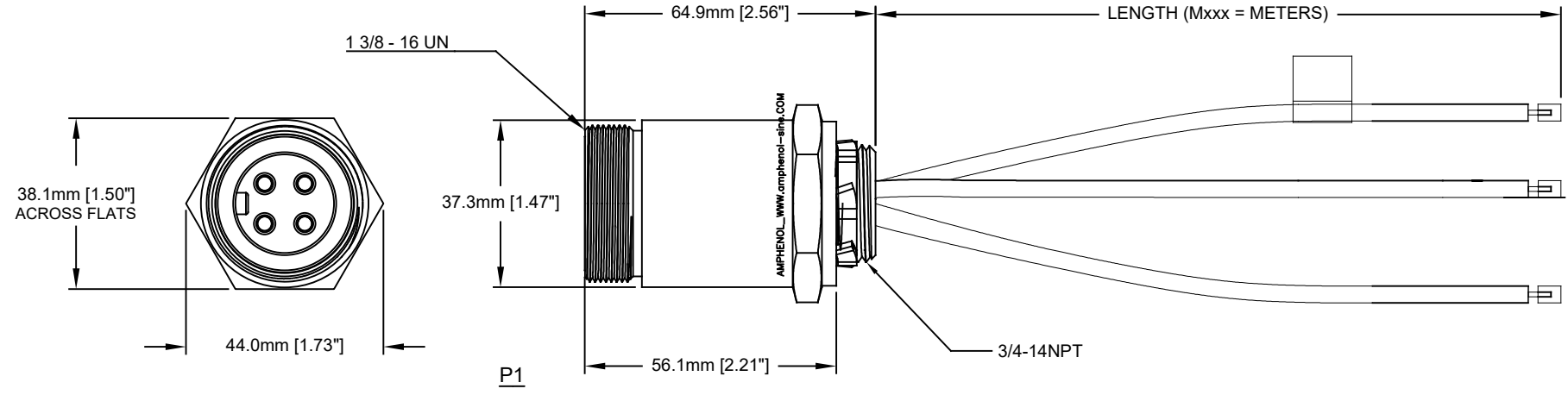

WIRING DIAGRAM

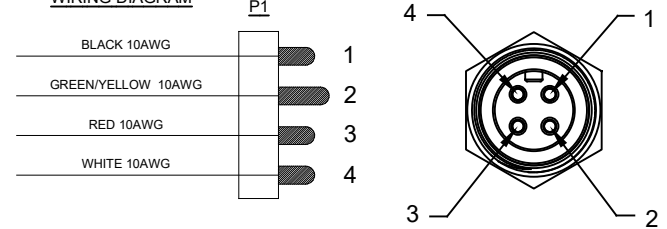

TECHNICAL DATA:

- MATERIALS:**
HOUSING: MACHINED ALUMINUM, ANODIZED
INSULATION INSERT: THERMOPLASTIC, UL 94/V-0
CONTACT: GOLD FLASH PLATING OVER COPPER ALLOY
CONDUCTOR INSULATION: PVC
NUMBER OF CONDUCTORS: (4) 10AWG
- ELECTRICAL DATA:**
CURRENT (MAX): 25A
VOLTAGE (MAX): 600V AC/DC
INSULATION RESISTANCE (MIN): 5000M OHMS
DIELECTRIC TEST VOLTAGE: 2200V
- MECHANICAL DATA:**
KNOCKOUT HOLE SIZE FOR PANEL MOUNT: 22.2mm [.88"]
TEMPERATURE RANGE: -40°C TO 90°C
PROTECTION: IP67 (MATED CONDITION)
MATING CYCLES: >500
VIBRATION RESISTANCE PER MIL-STD-202 METHOD 204
THERMAL SHOCK PER MIL-STD-202 METHOD 207
48 HOUR SALT SPRAY PER MIL-STD-202 METHOD 101
- RoHS COMPLIANT**
- UL 2237 LISTED ASSEMBLY**
UL FILE NUMBERS: E339703

Amphenol P/N	MOLEX	TURCK
P29057-M*	CR4C06A30A*	GSD40-*M/14.75/NPT
P29057-M.5	CR4C06A30A005	GSD40-.5M/14.75/NPT
P29057-M1	CR4C06A30A010	GSD40-1M/14.75/NPT
P29057-M2	CR4C06A30A020	GSD40-2M/14.75/NPT
P29057-M3	CR4C06A30A030	GSD40-3M/14.75/NPT

TOLERANCE	
0-2.99 M = +100.0/-25.0mm	0-9.99 FT = +4" / -1"
3-8.99 M = +150.0/-25.0mm	10.00-29.99 FT = +6" / -1"
9-14.99 M = +300.0/-25.0mm	30.00-49.99 FT = +12" / -1"
15-OVER M = +450.0/-25.0mm	50 FT-OVER = +18" / -1"

QUANTITY	PART NUMBER	DESCRIPTION	ITEM
MATERIALS LIST			
UNLESS OTHERWISE SPECIFIED		SIGNATURES	
1) All dimensions are in metric (mm).		DATE	
2) Tolerances are as follows:		DRAWN: KMM 12-MAY-14	
1 PL DEC ±0.30 Fractions ±1/64		CHECKED: MRF 12-MAY-14	
2 PL DEC ±0.15		ENGINEER: KMM	
3 PL DEC ±0.08		APPROVAL: RFC 12-MAY-14	
3) Note reference =		CUSTOMER:	
MATERIAL SPECIFICATIONS:		THIS DRAWING IS SUPPLIED FOR INFORMATION ONLY. DESIGN FEATURES, SPECIFICATIONS AND PERFORMANCE DATA SHOWN HEREON ARE THE PROPERTY OF THE AMPHENOL CORPORATION. NO RIGHTS OF REPRODUCTION ARE IMPLIED. ALL DIMENSIONS ARE SUBJECT TO NORMAL MANUFACTURING VARIATIONS.	
PROCESS SPECIFICATIONS:		SIZE	TYPE
NEXT ASSY:		C-	P29057-Mxxx
		DWG NO:	REVISION
			A1
		SCALE	SHEET 1 OF 1
		FULL	

TRN-435 PB LITE, 4 PIN, MALE REC., 10AWG, 3/4-14NPT
 DWG NO: C-P29057-Mxxx
 REV: A1
 SH: 1
 OF: 1