

LTC3566EUF: High Efficiency
USB Power Manager Plus 1A
Buck-Boost Converter

DESCRIPTION

Demonstration Circuit 1132A is a high efficiency USB Power/Li-Ion battery manager plus a 1A Buck-Boost regulator. The LTC3566EUF is available in a 24-pin (4mm × 4mm) QFN surface mount package.

LTC, LTC, Burst Mode, Bat-Track are registered trademarks of Linear Technology Corporation. PowerPath and SwitcherCAD are trademarks of Linear Technology Corporation. Other product names may be trademarks of the companies that manufacture the products.

PERFORMANCE SUMMARY Specifications are at T_A = 25°C

SYMBOL	PARAMETER	CONDITIONS	MIN	TYP	MAX	UNITS
V _{BUS}	Bus Input Voltage Range		4.35		5.5	V
V _{OUT}	Output Voltage Range	Range is mode and load dependant	3.5		4.6	V
V _{BAT}	Output Float Voltage	Constant voltage mode		4.2		V
I _{BAT}	Output Charge Current	Constant current mode		0.5	1	A
V _{OUT1}	Buck-Boost Output Voltage		3.25		3.30	V
I _{OUT1}	Buck-Boost Output Current				1	A

OPERATING PRINCIPLES

The LTC3566EUF is a full featured USB Power Manager and Li-Ion battery charger with a 1A Buck-Boost DC/DC regulator. The Bat-Track™ battery charger pre-regulator ensures the charger operates at the highest possible efficiency.

The LTC3566EUF is composed of 5 functional blocks, all working together: USB Power Manager, Pre-regulator, Battery Charger, Ideal Diode, and 1A Buck-Boost DC/DC regulator.

USB Power Manager

The USB Power Manager is used to manage the load that the LTC3566EUF system presents to the USB interface. The load current can be programmed by changing the CLPROG resistor (R2), and by setting the operating mode to 1X, 5X or 10X with the ILIM1, ILIM0 jumpers.

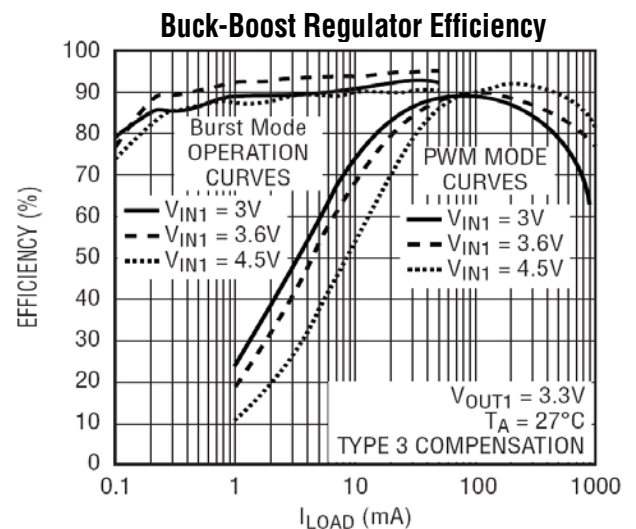

Pre-Regulator

The pre-regulator is a high efficiency buck regulator that produces a voltage at VOUT equal to the battery voltage plus 0.3V. By reducing the voltage across the charger to 0.3V the dissipation in the charger is greatly reduced, as compared with a linear charger.

Battery Charger

The battery charger operates in constant current mode, until the battery voltage rises to approximately the FLOAT voltage, of 4.2V, and then the charger switches to constant voltage mode.

The charge current is programmed by the PROG resistor (R3), and has been set to 500mA, on DC1132A, with a 2.00kΩ resistor. The battery charger implements trickle charging, for initial battery voltages less than 2.85V. It also implements a charge termination timeout of 4 hours, and a bad cell charging timeout of 30 minutes. An NTC input is used to determine if the battery temperature is suitable for charging, too hot or too cold.

The status of the charger, as well as any faults, are signaled with the $\overline{\text{CHRG}}$ pin.

Ideal Diode

The Ideal Diode block is composed of an internal Ideal Diode implemented with an on die MOSFET, as well as a MOSFET gate driver that allows the use of a parallel external MOSFET.

When the voltage on VOUT drops more than 15mV below the voltage at BAT, the Ideal Diode becomes active. This will happen when VBUS is not present, or the load on VOUT exceeds the power available from VBUS.

1A Buck-Boost DC/DC regulator

The Buck-Boost DC/DC regulator provides a regulated output that can be above and below the input voltage. The battery voltage will vary from VFLOAT (4.2V) to as low as 2.5V. The Buck-Boost regulator can supply a regulated 3.3V output over this entire battery voltage range.

The Buck-Boost is implemented with a full H-bridge switch, and proprietary control algorithm.

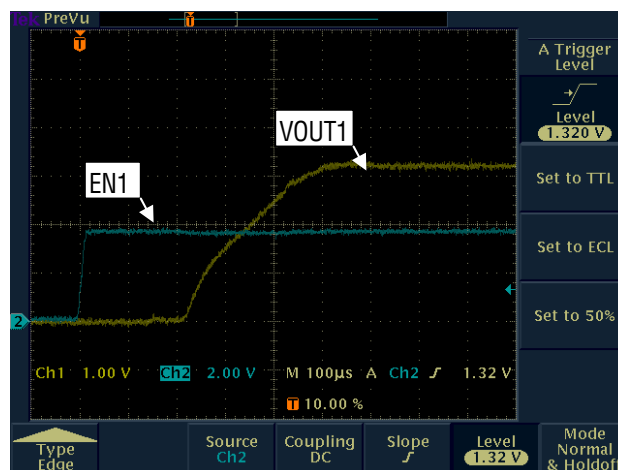

Figure 1. VOUT1 startup

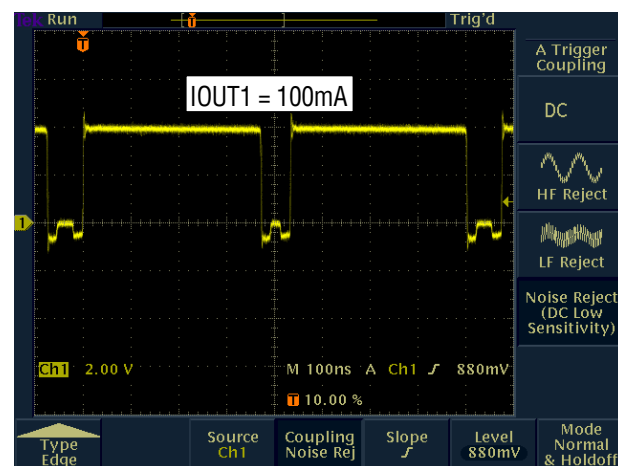

Figure 2. SWAB1 switching

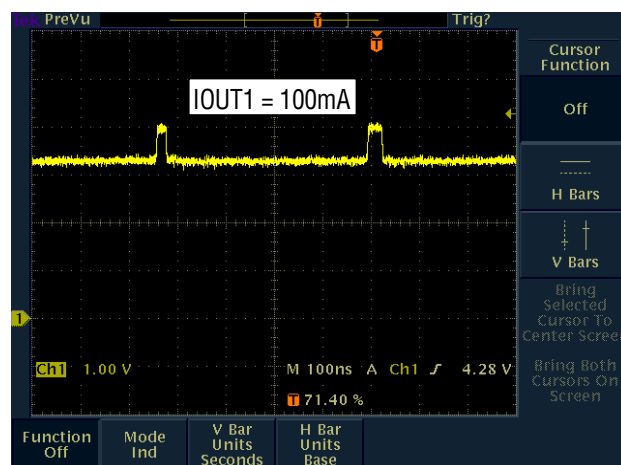

Figure 3. SWCD1 waveform

APPLICATIONS INFORMATION

The parasitic inductance in some USB cables may cause the VUSB voltage to overshoot at plug in. If this is the case it is recommended that the network of C1,R1 and C2 be added to the board to damp out this overshoot. While, at first glance, it may appear that C1 + C2 exceeds the USB specification for capacitive load on VUSB, in fact this is not the case. For most MLCC capacitors, with X7R/X5R dielectric the capacitance will be below 4.7 μ F, for DC biases of 5V.

The battery charger must see low impedance to ground, which is the case when a battery is attached. In the event that a battery emulator is being used, or the impedance to ground is above 0.5 Ω , the circuit of C5 and R8-10 is recommended. The Buck-Boost regulator should be compensated with a Type III compensator, as shown on the schematic. The Buck, Buck-Boost and pure Boost regions of operation have different poles/zeroes and PWM gains. In particular, the Buck-Boost and pure Boost regions have a RHP zero, that must be accommodated.

It is recommended that the stabilization be verified in all three regions of operation, with minimum and maximum load.

QUICK START PROCEDURE

Using short twisted pair leads for any power connections and with all loads and power supplies off, refer to Figures 4 and 5 for the proper measurement and equipment setup. Follow the procedure below:

1. Set PS1 to 5V, and PS2 to 3.6V.
2. Observe I_{VBUS} (AM1). The USB input current limit is programmed for 1X (100mA), but the battery charge current is programmed to 500mA. So the USB input current limit is activated, and the charger cannot get enough current to charge at 500mA. Consequently, V_{CLPROG} is at $\sim 1.15V$, but V_{PROG} cannot rise to 1V.
3. Set ILIM1 (JP2) to "HI" and ILIM0 (JP3) to "HI". Observe I_{VBUS} (AM1). The USB input current limit is now 5X (500mA), and the charger can get enough current to charge the battery at 500mA. Consequently, V_{CLPROG} is nearly 1.15V, and V_{PROG} is at 1V.
4. Set ILIM1 (JP2) to "LO". Observe I_{VBUS} (AM1), V_{CLPROG} (VM6) and V_{PROG} (VM5). The USB input current limit is now 10X (1A), and the charger can get enough current to charge the battery at 500mA. Consequently, V_{CLPROG} is at 0.6V ($0.5 * 1.15V$), and V_{PROG} is at 1V.
5. Set PS1 to 0V, and LOAD1 to 1A. Observe VOUT (VM2) and $V_{(BAT,OUT)}$. Verify that $3.55V < VOUT < 3.60V$, and $(V_{BAT} - VOUT) < 0.05V$. The USB input voltage is off causing VOUT to fall. When VOUT falls to 15mV below V_{BAT} , the LTC3566 activates the ideal diode and supplies current to VOUT from the BAT pin.
6. Set LOAD1 to 400mA and PS1 to 5V. Observe VOUT (VM2), V_{CLPROG} (VM6) and V_{PROG} (VM5). The USB input current limit is 10X (1A), and the charger can get enough current to charge the battery at 500mA. In addition, VOUT is being loaded at 400mA, producing an aggregate load at VBUS of nearly 860mA. Consequently, V_{CLPROG} is nearly 1.15V, and V_{PROG} is at 1V.
7. Observe VOUT (VM2) and VOUT1 (VM4). The Buck-Boost regulator has been enabled at no load. The nominal output voltage on the Buck-Boost regulator is 3.3V.
8. Leave LOAD1 at 400mA, and set LOAD2 to 400mA. Observe VOUT (VM2), VOUT1 (VM4) and V_{CLPROG} (VM6). The USB input current limit is 10X (1A), and the charger can get enough current to charge the battery at 500mA. In addition, VOUT1 is being loaded at 400mA, producing an aggregate load at VBUS of nearly 860mA. Consequently, V_{CLPROG} is nearly 1.15V, and V_{PROG} is at 1V.
9. Set \overline{CHRGEN} (JP4) to "HI". Set LOAD2 to 1A. Observe VOUT (VM2), VOUT1 (VM4), and V_{CLPROG} (VM6). The USB input current limit is 10X (1A), and the charger is off. In addition, VOUT1 is being loaded at 1A, producing an aggregate load at VBUS of nearly 860mA. Consequently, V_{CLPROG} is nearly 1.15V, and V_{PROG} is at 1V.
10. Set LOAD2 to 0A, and \overline{CHRGEN} (JP4) to "LO". Set NTC (JP6) to "EXT". \overline{CHRG} LED should flash. The charger is now enabled, but the voltage is indicating that the battery temperature is very cold.
11. Set NTC (JP6) to "INT" and EN1 (JP1) to "ON".

QUICK START GUIDE FOR DEMONSTRATION CIRCUIT DC1132A HIGH EFFICIENCY USB POWER MANAGER PLUS 1A BUCK-BOOST CONVERTER

LTC3566EUF

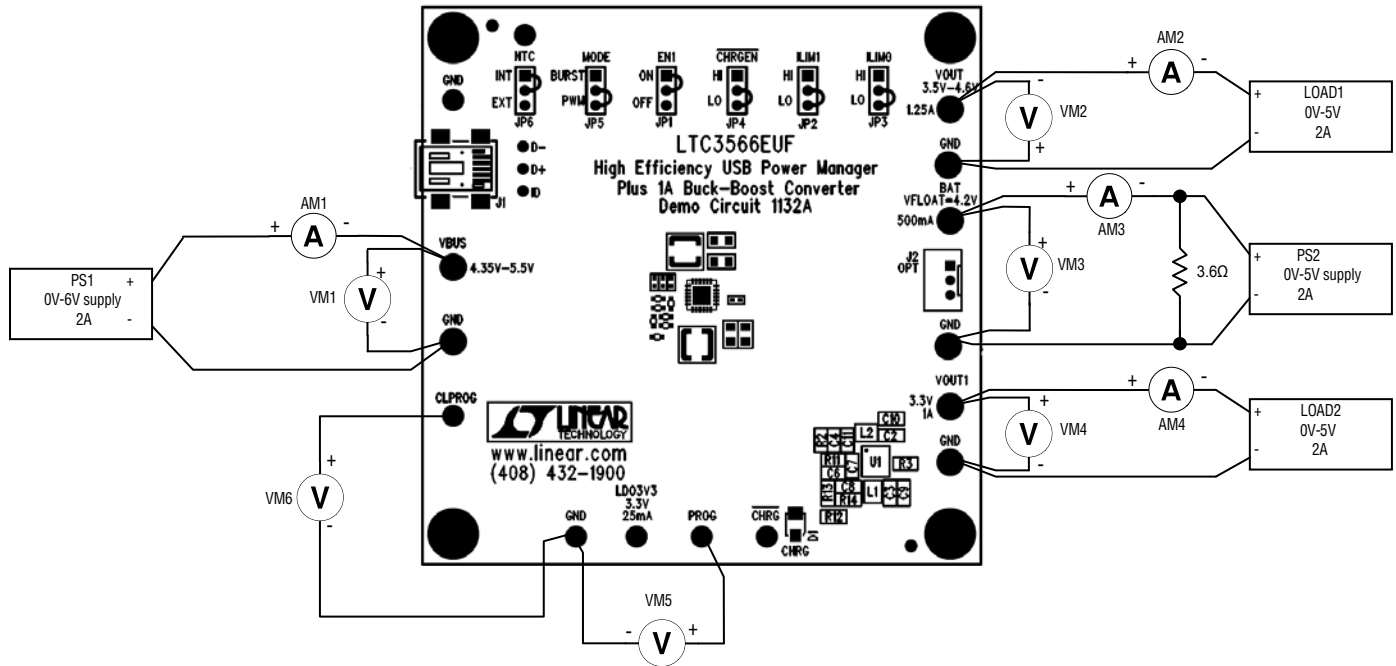

Figure 4. Proper Measurement Equipment Setup for DC1132A

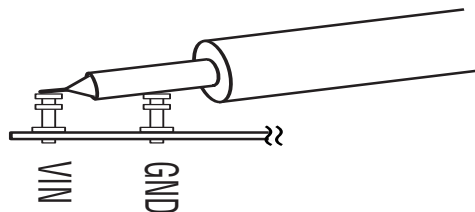

Figure 5. Measuring Input or Output Ripple

QUICK START GUIDE FOR DEMONSTRATION CIRCUIT DC1132A HIGH EFFICIENCY USB POWER MANAGER PLUS 1A BUCK-BOOST CONVERTER

LTC3566EUF

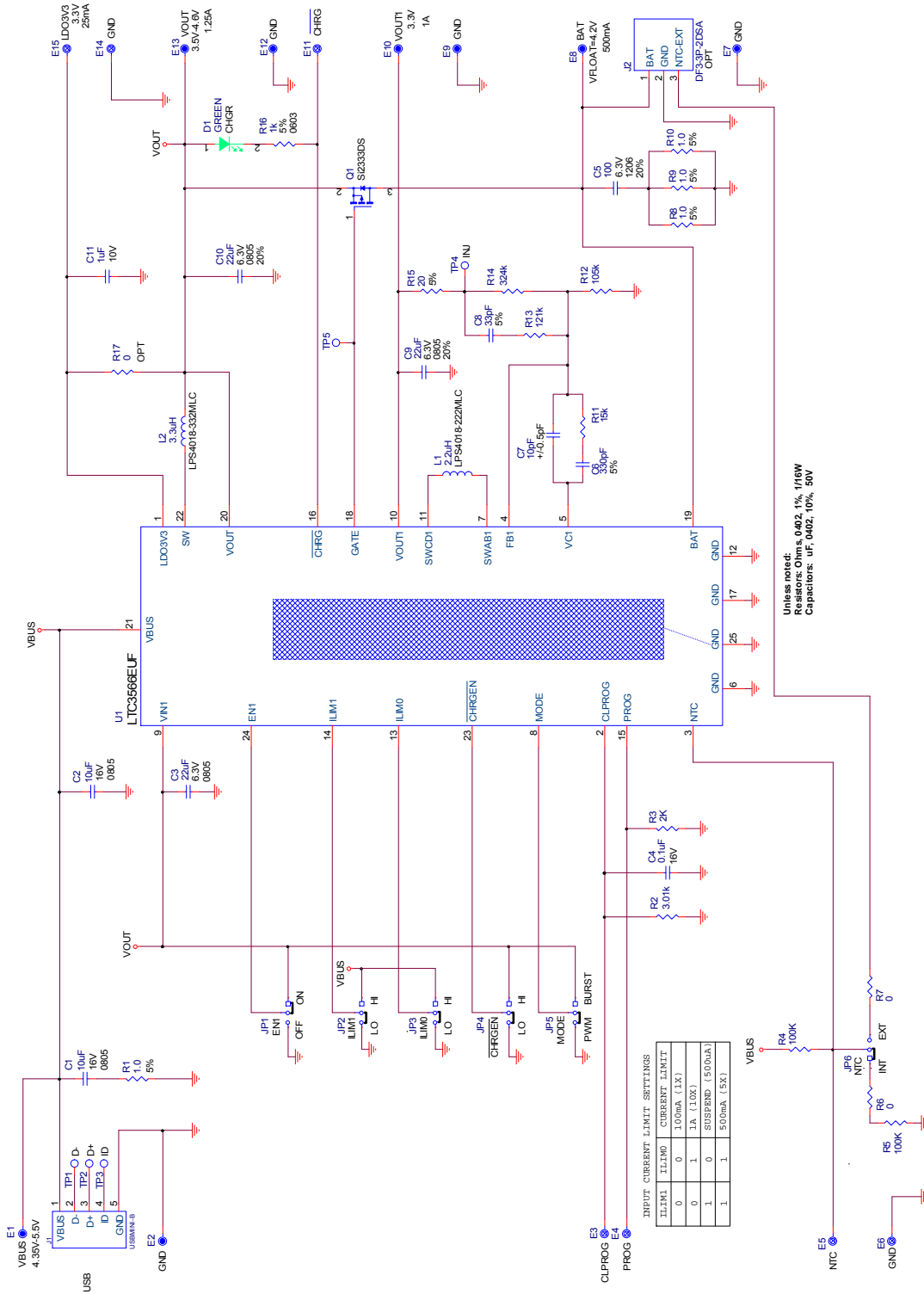

Figure 6. DC1132A Schematic

QUICK START GUIDE FOR DEMONSTRATION CIRCUIT DC1132A HIGH EFFICIENCY USB POWER MANAGER PLUS 1A BUCK-BOOST CONVERTER

LTC3566EUF

Qty	Reference	Part Description	Manufacture / Part #
REQUIRED CIRCUIT COMPONENTS:			
1	C2	CAP, CHIP, X5R, 10 μ F, \pm 10%, 16V, 0805	MURATA, GRM21BR61C106KE15L
2	C3,C9,C10	CAP, CHIP, X5R, 22 μ F, \pm 20%, 6.3V, 0805	TAIYO-YUDEN, JMK212BJ226MG
3	C4	CAP, CHIP, X7R, 0.1 μ F, \pm 10%, 16V, 0402	MURATA, GRM155R71C104KA88
4	C6	CAP, CHIP, BX, 330pF, \pm 5%, 50V, 0402	VISHAY, VJ0402X331JXXA
5	C7	CAP, CHIP, COG, 10pF, \pm 0.5pF, 50V, 0402	VISHAY, VJ0402A100DXXA
6	C8	CAP, CHIP, COG, 33pF, \pm 5%, 50V, 0402	VISHAY, VJ0402A330JXXA
7	C11	CAP, CHIP, X5R, 1.0 μ F, \pm 10%, 10V, 0402	MURATA, GRM155R1A105KE15D
8	R2	RES, CHIP, 3.01k Ω , \pm 1%, 1/16W, 0402	VISHAY, CRCW04023K01FKED
9	R3	RES, CHIP, 2.0k Ω , \pm 1%, 1/16W, 0402	VISHAY, CRCW04022K00FKED
10	R11	RES, CHIP, 15k Ω , \pm 1%, 1/16W, 0402	VISHAY, CRCW040215K0FKED
11	R12	RES, CHIP, 105k Ω , \pm 1%, 1/16W, 0402	VISHAY, CRCW0402105KFKED
12	R13	RES, CHIP, 121k Ω , \pm 1%, 1/16W, 0402	VISHAY, CRCW0402121KFKED
13	R14	RES, CHIP, 324k Ω , \pm 1%, 1/16W, 0402	VISHAY, CRCW0402324KFKED
14	L1	IND, SMT, 2.2 μ H, \pm 20%, 70m Ω , 2.5A, 4.4mmX4.4mm	COILCRAFT, LPS4018-222MLC
15	L2	IND, SMT, 3.3 μ H, \pm 20%, 80m Ω , 2.2A, 4.4mmX4.4mm	COILCRAFT, LPS4018-332MLC
16	U1	High Efficiency USB Power Manager Plus 1A Buck-Boost Converter	LINEAR TECH., LTC3566EUF
ADDITIONAL DEMO BOARD CIRCUIT COMPONENTS:			
1	C1	CAP, CHIP, X5R, 10 μ F, \pm 10%, 16V, 0805	MURATA, GRM21BR61C106KE15L
2	C5	CAP, CHIP, X5R, 100 μ F, \pm 20%, 6.3V, 1206	MURATA, GRM31CR60J107ME39L
3	D1	LED, GREEN	PANASONIC, LN1351C-(TR)
4	Q1	XSTR, MOSFET, P-CHANNEL	SILICONIX, Si2333DS
5	R1,R8,R9,R10	RES, CHIP, 1.0 Ω , \pm 5%, 1/16W, 0402	VISHAY, CRCW04021R00JNED
6	R4, R5	RES, CHIP, 100k Ω , \pm 1%, 1/16W, 0402	VISHAY, CRCW0402100KFKED
7	R6,R7,R17-OPT	RES, CHIP, 0 Ω jumper, 1/16W, 0402	VISHAY, CRCW04020000Z0ED
8	R15	RES, CHIP, 20.0 Ω , \pm 5%, 1/16W, 0402	VISHAY, CRCW040220R0JNED
9	R16	RES, CHIP, 1k Ω , \pm 5%, 1/10W, 0603	VISHAY, CRCW06031K00JNED
HARDWARE FOR DEMO BOARD ONLY:			
1	J1	CONN, USB MINI-B	TYCO, 1734035-2
2	J2-OPT	CONN, DF3-3P-2DSA	HIROSE, DF3-3P-2DSA
3	JP1,JP2,JP3,JP4,JP5,JP6	HEADER, 3 PINS 2mm	SAMTEC, TMM-103-02-L-S
4	JP1,JP2,JP3,JP4,JP5,JP6	SHUNT, 2mm	SAMTEC, 2SN-BK-G
5	E1,E2,E7,E8,E9,E10,E12,E13	TURRET, 0.09 DIA	MILL-MAX, 2501-2
6	E3,E4,E5,E6,E11,E14,E15	TURRET, 0.061 DIA	MILL-MAX, 2308-2
7		STAND-OFF, NYLON 0.375" tall (SNAP ON)	KEYSTONE, 8833 (SNAP ON)

Figure 7. DC1132A BOM