

THIS DRAWING IS UNPUBLISHED. RELEASED FOR PUBLICATION  
 © COPYRIGHT - By - ALL RIGHTS RESERVED.

LOC	DIST	REVISIONS					
GP	00	P	LTR	DESCRIPTION	DATE	DWN	APVD
		A		INITIAL RELEASE	01/AUG/11	ECC	PB

HV-4

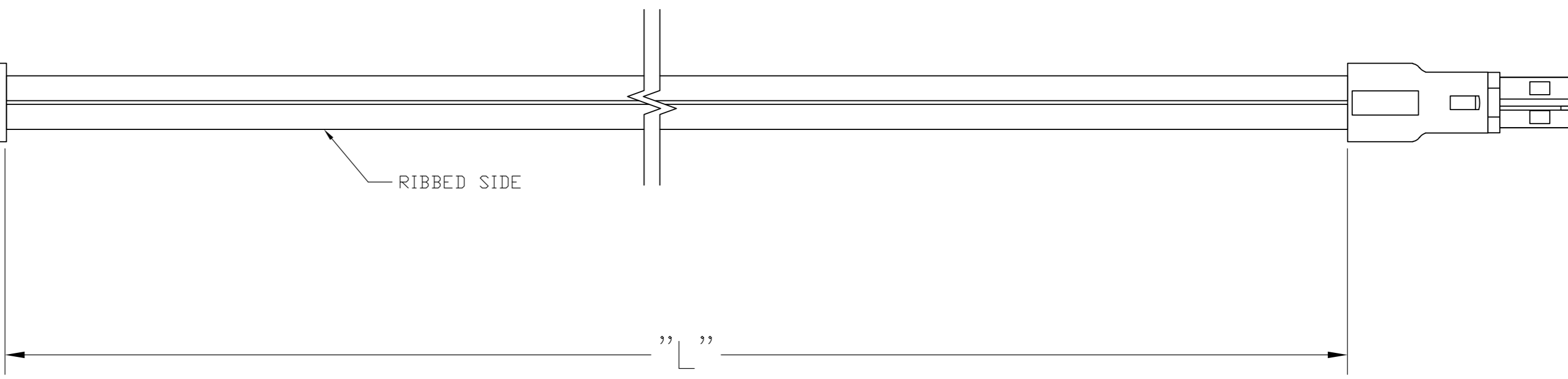
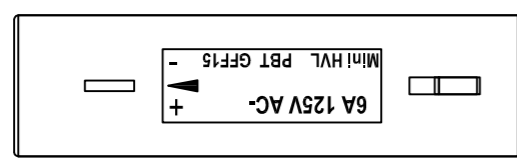
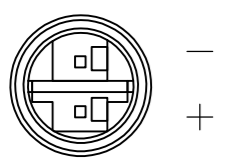

HV-4

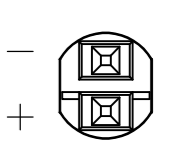

WIRING SCHEDULE <span style="float: right;">3</span>			
OUTLET		SIDE	PLUG
1	+	RIBBED	1
2	-	SMOOTH	2

1. PACKAGING ACC. TO TE SPEC.107-18032  
BUNDLE EVERY 25 ASSEMBLIES WITH A RUBBER BAND
2. ELECTRICAL TEST CONTAINING "SHORT CIRCUIT TEST, CONTINUITY AND ACCURATE CAVITY ASSIGNMENT TEST" ACC. TO TE-SPEC.108-18857, SUBSECTION 3.1.1

3 WIRING SCHEDULE AS SHOWN

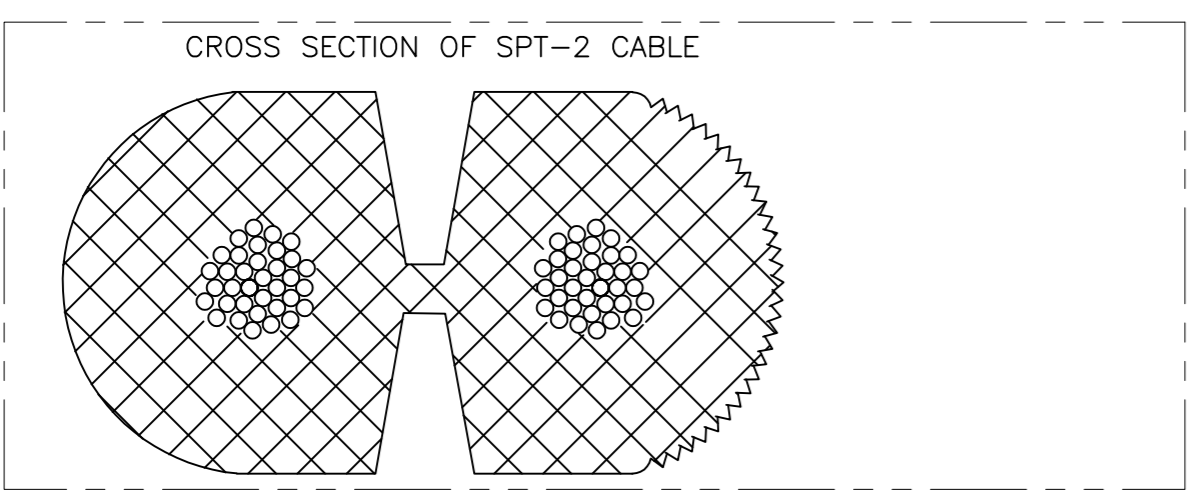

16.0 FT	±3.84	2181191-8
14.0 FT	±3.36	2181191-7
12.0 FT	±2.88	2181191-6
10.0 FT	±2.4	2181191-5
8.0 FT	±1.92	2181191-4
6.0 FT	±1.44	2181191-3
4.0 FT	±.96	2181191-2
2.0 FT	±.48	2181191-1
"L"	TOLERANCES [INCHES]	TE P/N

THIS DRAWING IS A CONTROLLED DOCUMENT.		DWN	16/JUN/11	<b>TE</b> TE Connectivity	
		CHK	13/JUL/11		
		APVD	01/AUG/11		
		PRODUCT SPEC			
DIMENSIONS:	TOLERANCES UNLESS OTHERWISE SPECIFIED:	NAME		CABLE ASSEMBLY, NECTOR, HV-4, OUTLET TO PLUG	
INCHES		APPLICATION SPEC		-	
	0 PLC ± -	SIZE		RESTRICTED TO	
	1 PLC ± -	CAGE CODE		-	
	2 PLC ± -	DRAWING NO		-	
	3 PLC ± -	A2 00779		-	
	4 PLC ± -	C=2181191		-	
	ANGLES ± -	SCALE		N.T.S.	
MATERIAL	FINISH	WEIGHT		SHEET 1 of 1	
-	-	CUSTOMER DRAWING		REV A	

2181191