

PART NUMBER LARGE QTY.	NUMBER OF POS.	"L"	"M"
0-161394-1	1	5,08	-
0-161394-2	2	7,62	2,54
0-161394-3	3	10,16	5,08
0-161394-4	4	12,70	7,62
0-161394-5	5	15,24	10,16
0-161394-6	6	17,78	12,70
0-161394-7	7	20,32	15,24
0-161394-8	8	22,86	17,78
0-161394-9	9	25,40	20,32
1-161394-0	10	27,94	22,86
1-161394-1	11	30,48	25,40
1-161394-2	12	33,02	27,94
1-161394-3	13	35,56	30,48
1-161394-4	14	38,10	33,02
1-161394-5	15	40,64	35,56
1-161394-6	16	43,18	38,10
1-161394-7	17	45,72	40,64
1-161394-8	18	48,26	43,18
1-161394-9	19	50,80	45,72
2-161394-0	20	53,34	48,26
2-161394-1	21	55,88	50,80
2-161394-2	22	58,42	53,34
2-161394-3	23	60,96	55,88
2-161394-4	24	63,50	58,42
2-161394-5	25	66,04	60,96
2-161394-6	26	68,58	63,50
2-161394-7	27	71,12	66,04
2-161394-8	28	73,66	68,58
2-161394-9	29	76,20	71,12
3-161394-0	30	78,84	73,66

DO NOT SCALE  
DIMENSIONS IN mm

METRIC



AMP PRODUCT SPEC.: 108-19036.

MATERIAL:

HOUSING : 20% G.F. POLYESTER , COLOUR : GREY.

ACTUATOR: 20% G.F. POLYESTER , COLOUR : RED.

CONTACTS: PHOSPHOR-BRONZE.

PLATING: MIN. 2,5µm TIN/LEAD 93/7.

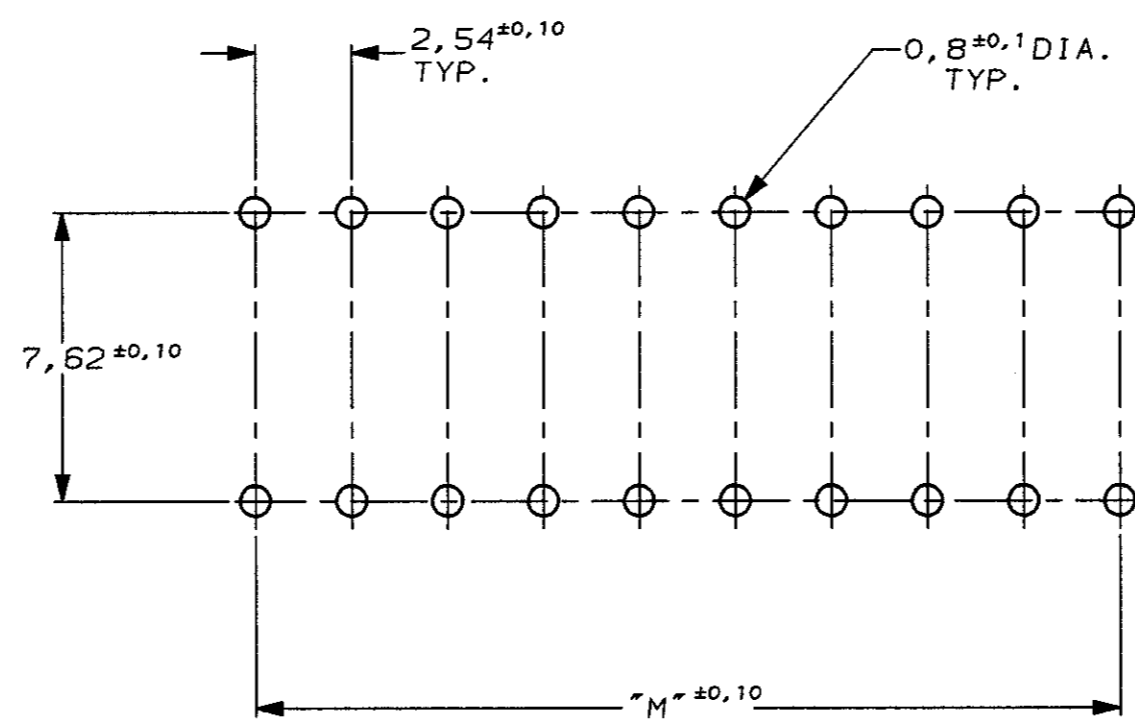
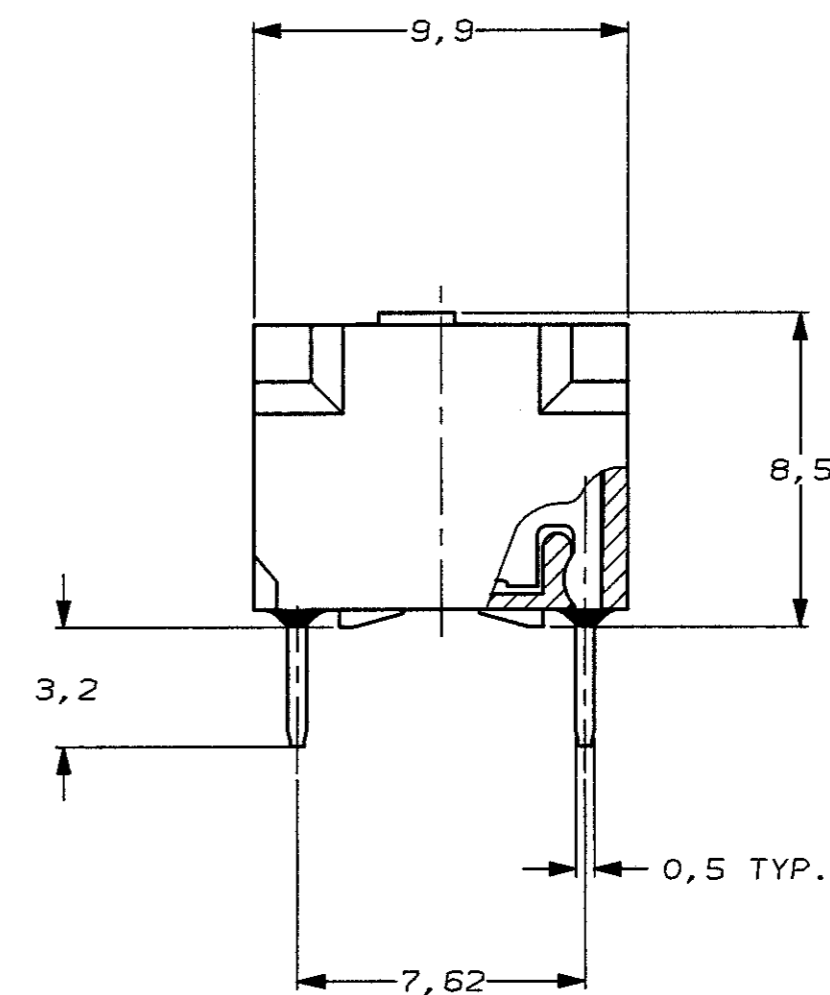
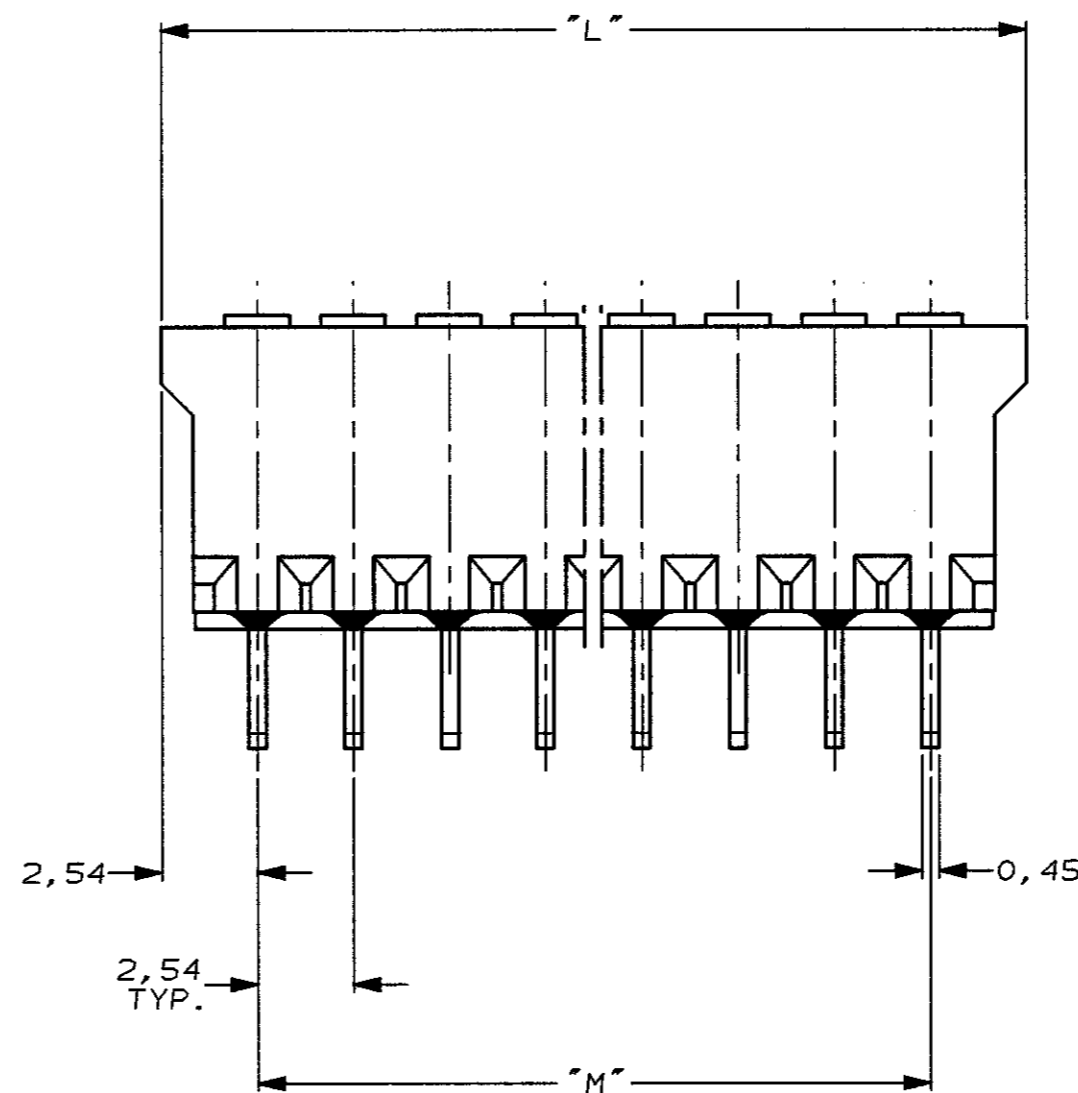
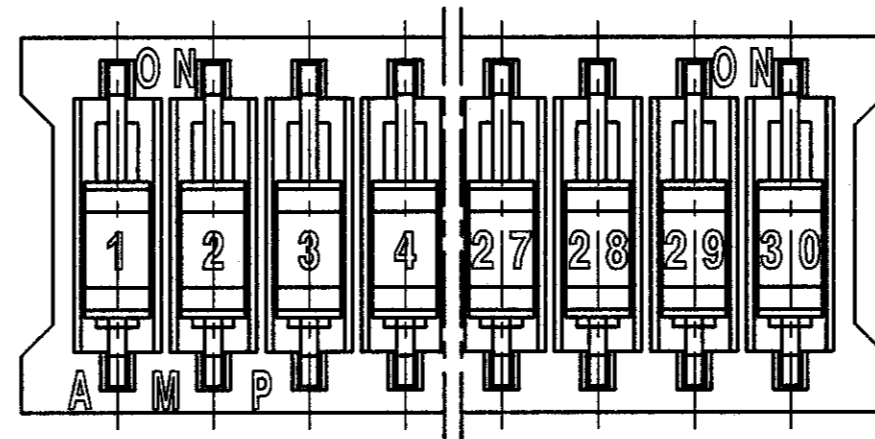

RECOMMENDED P.C. BOARD HOLE PATTERN.  
P.C. BOARD THICKNESS : 1,6mm.

SWITCH HOUSINGS MAY HAVE  
PROFILE A , B OR C.

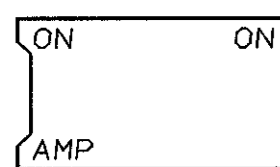

A

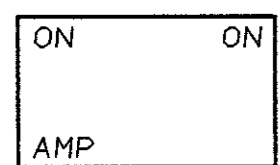

B

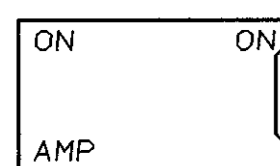

C

				FINISH	MATERIAL	PARTNUMBER
-	-	-	-	-	-	CUSTOMER DRAWING FOR REFERENCE ONLY WILL NOT BE UPDATED
-	-	-	-	-	-	© COPYRIGHT 19- BY AMP HOLLAND B.V. ALL INTERNATIONAL RIGHTS RESERVED. AMP PRODUCTS MAY BE COVERED BY U.S. AND FOREIGN AND/OR PATENTS PENDING.
-	-	-	-	-	-	THIS DRAWING IS UNPUBLISHED RELEASED FOR PUBLICATION
				<b>AMP</b>		AMP HOLLAND B.V. s-Hertogenbosch, The Netherlands.
				NAME		
0	EH-0991-96	D.K.	M.G.	21 AUG 96	TINPLATED DIP SWITCH SEALED VERSION	
LTR.	REVISION RECORD	DR.	CHK.	DATE		
DR.:	D. KESSLER	CHK.:	M. GOSSELINK	APP.:	E. HESTENS	DWG. No. 161394
DATE:	21 AUG 96	DATE:	12-9-96	DATE:	12/9/96	REV. LTR. SHEET 0 1 OF 1 A2