

DWG. NO.
SA25594

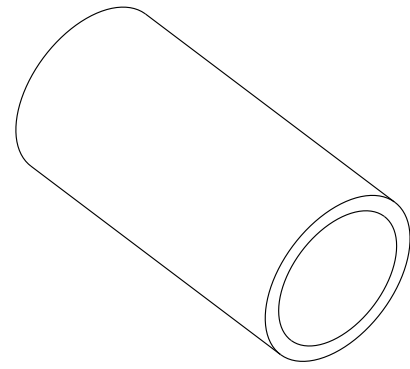
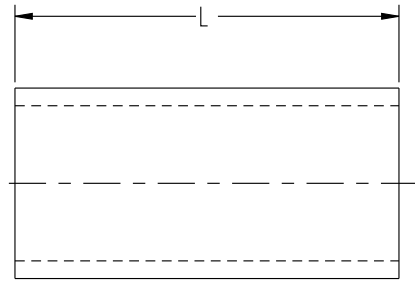
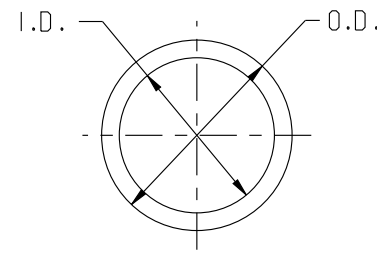

SCALE 8:1

NOTE:

1. MATERIALS: AS NOTED.
 2. PLATING: TIN PLATED.
 3. SURFACE TREATMENT : IRIDITE OVER CADMIUM PLATE.
- * THESE SIZES NOT IRIDITED.

THIS DRAWING IS A CONTROLLED DOCUMENT FOR SOURIAU USA, INC. IT IS SUBJECT TO CHANGE WITHOUT NOTIFICATION. CONTACT THE DOCUMENT CONTROL CENTER FOR THE LATEST REVISION.

THE INFORMATION CONTAINED IN THIS DRAWING IS CONFIDENTIAL AND MAY NOT BE DISCLOSED WITHOUT WRITTEN CONSENT FROM SOURIAU USA, INC.

OUTER HYRING								
L=.25		DIAMETER (IN INCH.)		INSTALLATION TOOLS				
CAT. NO.	COLOR	I.D.	O.D.	RATCHET HYTOOLS		HYTOOLS	HYPRESSES	
				MR8PV TYPE INCLUDES DIE	M8ND DIE SET NO.	Y10R Y10C-1 DIE SET NO.	Y10NCP DIE SET NO.	Y8ND DIE SET NO.
YOC 70	*TIN	.101	.124	MR8PV-14S		R7VST		
YOC 80	BLUE	.125	.156	MR8PV-S	N8VST	R8VST	N8VST	
YOC 90	PURPLE	.149	.179	MR8PV-S, MR8PV-1S	N10VST	R14VST-5	N10VST	
YOC 100	YELLOW	.156	.196	MR8PV-S, MR8PV-1S	N10VST	R14VST-5	N10VST	
YOC 110	BLUE	.180	.204	MR8PV-S, MR8PV-1S	N10VST	R14VST-5	N10VST	
YOC 112	BLUE	.175	.215	MR8PV-S, MR8PV-1S	N12VST	R14VST-5	N12VST	
YOC 120	ORANGE	.187	.227	MR8PV-S, MR8PV-1S	N12VST	R14VST-5	N12VST	
YOC 128	*TIN	.199	.235	MR8PV-S, MR8PV-1S	N12VST	R14VST-5	N12VST	
YOC 130	YELLOW	.207	.243	MR8PV-S, MR8PV-1S MR8PV-10S	N12VST N13VST	R14VST-5 R14VST-3	N12VST N13VST	
YOC 140	GREEN	.219	.250	MR8PV-1S MR8PV-11S	N14VST	R14VST-5	N14VST	
YOC 150	ORANGE	.235	.266	MR8PV-2	N16VT	R18VT-3	N16VT	
YOC 160	YELLOW	.261	.297	MR8PV-2	N16VT	R18VT-3	N16VT	
YOC 180	PURPLE	.281	.331	MR8PV-2		R18VT-3		
YOC 190	GREEN	.300	.335	MR8PV-2		R18VT-3		
YOC 200	YELLOW	.312	.362	MR8PV-3		R20VT		
YOC 220	ORANGE	.344	.394	MR8PV-4 MR8PV-11S		R22VT		
YOC 240	BLUE	.375	.406	MR8PV-7		R24VT		
YOC 250	RED	.405	.453	MR8PV-6		R25VT		
YOC 320G1	PURPLE	.500	.550			R29VT		
YOC 371G1	*TIN	.580	.620			R32VT		
YOC 370	*TIN	.705	.755	MD5-36				

INNER HYRING			
L=.31		DIAMETER (IN INCH.)	
CAT. NO.	COLOR	I.D.	O.D.
YIC046	*TIN	.046	.070
YIC058	YELLOW	.058	.083
YIC063	RED	.063	.088
YIC071	GREEN	.071	.096
YIC080	BLUE	.080	.104
YIC090	ORANGE	.090	.114
YIC101	YELLOW	.101	.124
YIC109	RED	.109	.131
YIC115	*TIN	.115	.146
YIC124	GREEN	.124	.145
YIC125	YELLOW	.125	.156
YIC134	ORANGE	.134	.156
YIC150	BLUE	.150	.181
YIC156	RED	.166	.191
YIC180	GREEN	.180	.204
YIC194	BLUE	.194	.255
YIC219	*TIN	.219	.243
YIC261	BLUE	.261	.297
YIC297	RED	.297	.337
YIC375G1	*TIN	.375	.423
YIC472G1	*TIN	.472	.516
YIC495G1	*TIN	.495	.535
YIC340	*TIN	.340	.390

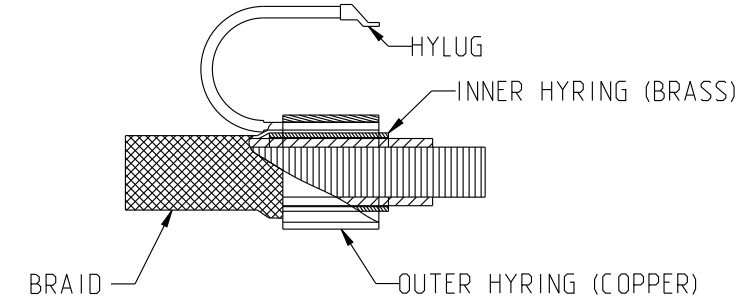

PROPER SELECTION OF HYRINGS:

OUTER FERRULES MAY BE USED IN COMBINATION WITH ANY INNER FERRULES, DEPENDING ON THE SIZE OF THE CONDUCTOR, THE THICKNESS OF THE SHIELD AND THE SIZE OF THE GROUND TAP. HOWEVER, DUE TO VARIATION IN INSULATION DIAMETER AND BRAID CONSTRUCTION, THE RECOMMENDED BASIS FOR SIZE SELECTION FOR SHIELDED CABLE IS A FACTORY-INSTALLED, SAMPLE CONNECTION MADE ON ACTUAL WIRE TO BE USED. IF IT IS NOT CONVENIENT TO FORWARD WIRE SAMPLES, SIZES CAN BE DETERMINED AS FOLLOWS:

DETERMINE O.D. OF INNER INSULATION. SELECT INNER HYRING FROM CHART ABOVE HAVING I.D. A MINIMUM OF .005 GREATER THAN THIS DIAMETER. TO THE O.D. OF THIS FERRULE ADD .025 (FOR SINGLE BRAID) PLUS .040 FOR WIRE TAP (UPTO #18), IF USED, AND SELECT OUTER FERRULE HAVING I.D. ATLEAST EQUAL TO THIS FIGURE. THE PROPER CRIMPING TOOL FOR EACH OUTER HYRING IS LISTED ON TABLE.

SUPERSEDES: SA-25594-16

W	REVISED PER ECN 11866	CJM 12-12-12	SDH 12-12-12
REV	DESCRIPTION	BY DATE	CHKD DATE

DRAWING TITLE
COLORED FERRULES

CAT NO. **YIC & YOC _____ (SEE TABLE)**

CAGE NO: 09922 SIZE: B

CUSTOMER

INTERPRET THIS DRAWING IN ACCORDANCE WITH ASME Y14.5M-1994.



SOURIAU
Connection Technology

www.souriau.com

APPROVAL

DRAWN:	NVM	11-14-11
CHKD :	SDH	11-14-11
DSGN :	XXX	mm-dd-yy
MFG :	DH	11-14-11
QC :	BB	11-14-11
DRAWING SCALE:		8:1
DRAWING NO.		REV
SA25594		W
1 OF 1		

LINEAR MEASURE: INCH INCH [mm]

THIRD ANGLE PROJECTION

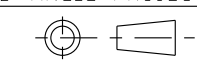

TOLERANCES UNLESS OTHERWISE SPECIFIED

No. OF PLACES	INCH [mm]
ONE PLACE	±.1 [±3]
TWO PLACES	±0.02 [±.5]
THREE PLACES	±0.005

ANGLES ±1°

B

A