

UNCONTROLLED DOCUMENT

CAUTION: PRESSURE SENSITIVE ASSEMBLY  
AVOID APPLYING PRESSURE TO LED  
DURING PANEL ASSEMBLY.

PART NUMBER		REV.
SSI-LXR5010HGW-150		A
REV.	E.C.N. NUMBER AND REVISION COMMENTS	DATE
A	E.C.N. #10BRDR. & REDRAWN IN 3D.	1.5.02

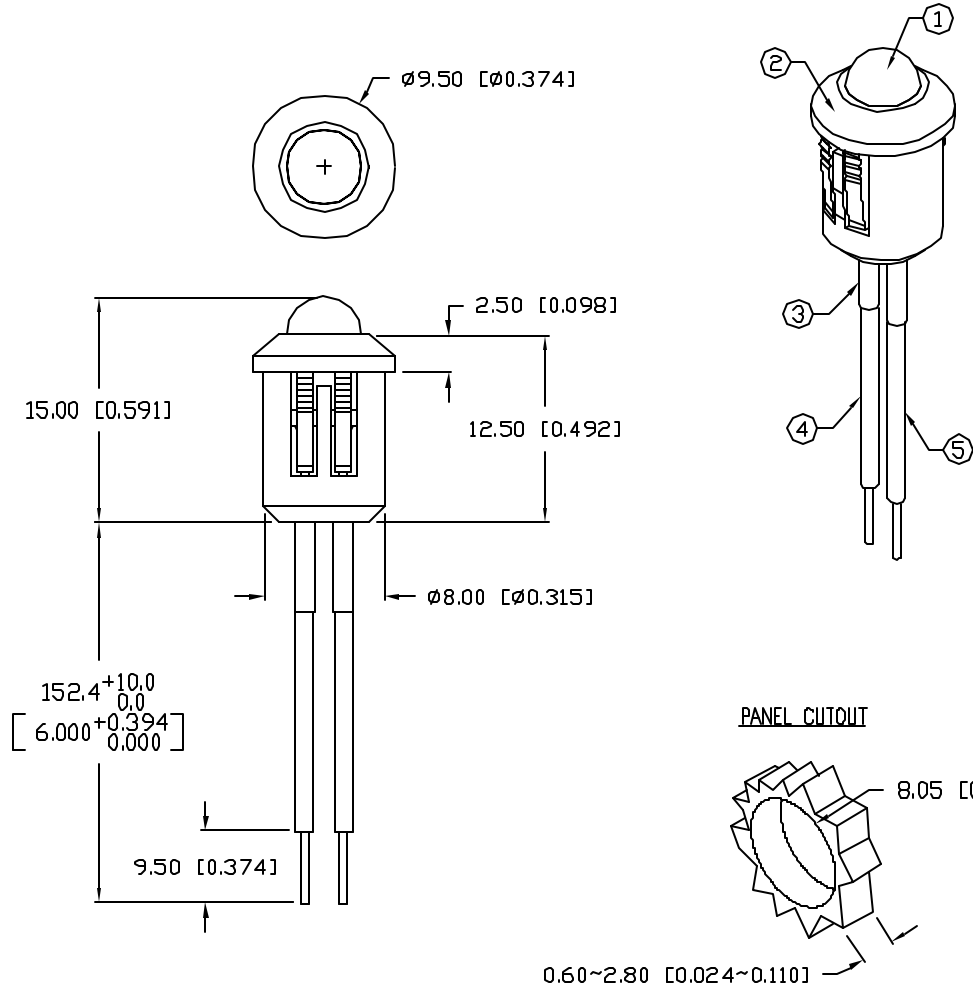

ELECTRO-OPTICAL CHARACTERISTICS  $T_A=25^\circ\text{C}$   $I_f=20\text{mA}$

PARAMETER	MIN	TYP	MAX	UNITS	TEST COND
PEAK WAVELENGTH		700 (RED)		nm	
		565 (GREEN)		nm	
FORWARD VOLTAGE (R/G)		2.0/2.2	2.5/2.6	$V_f$	
REVERSE VOLTAGE	5.0			$V_r$	$I_f=100\mu\text{A}$
AXIAL INTENSITY (R/G)		6/25		mcd	$I_f=20\text{mA}$
VIEWING ANGLE		60		2x theta	
EMITTED COLOR:	RED/GREEN				
EPOXY LENS FINISH:	MILKY WHITE DIFFUSED				

LIMITS OF SAFE OPERATION AT  $25^\circ\text{C}$

PARAMETER	COLORS	MAX	UNITS
PEAK FORWARD CURRENT*		150	mA
STEADY CURRENT		25	mA
POWER DISSIPATION	(R/G)	120/105	mW
DERATE FROM $25^\circ\text{C}$		-1.2	$\text{mW}/^\circ\text{C}$
OPERATING, STORAGE TEMP.		-40 TO +85	$^\circ\text{C}$

\*  $t < 10\mu\text{s}$

NOTES:

1. SSL-LX5093HCW, RED/GREEN LED. TRIM LEADS TO 3-4mm.
2. SSH-RTF5010, BLACK HOLDER.
3. LXP-HEATSHRINK-2, (2 PCS.) 1/16" x 1/2".
4. RED ANODE: LXP-WST24RDT0C, CUT 160mm LONG, STRIP ENDS 3mm & 9.5mm.
5. GREEN ANODE: LXP-WST24BLT0C, CUT 160mm LONG, STRIP ENDS 3mm & 9.5mm.

UNCONTROLLED DOCUMENT

\*UNLESS OTHERWISE SPECIFIED TOLERANCES PER DECIMAL PRECISION ARE: X=±1 (±0.039), XX=±0.5 (±0.020), XXX=±0.25 (±0.010), XXXX=±0.127 (±0.005). LEAD SIZE=±0.05 (±0.002), LEAD LENGTH=±0.75 (±0.030). MIN.=<sup>+DECIMAL PRECISION</sup>-0.00 MAX.=<sup>+0.00</sup>-DECIMAL PRECISION

REV.	PART NUMBER
A	SSI-LXR5010HGW-150
T-5mm, RED/GREEN LED PANEL INDICATOR, MILKY WHITE DIFFUSED LENS, 6" WIRE LEADS.	

CONFIDENTIAL INFORMATION  
THE INFORMATION CONTAINED IN THIS DOCUMENT IS THE PROPERTY OF LUMEX INC. EXCEPT AS SPECIFICALLY AUTHORIZED IN WRITING BY LUMEX INC., THE HOLDER OF THIS DOCUMENT SHALL KEEP ALL INFORMATION CONTAINED HEREIN CONFIDENTIAL AND SHALL PROTECT SAME IN WHOLE OR IN PART FROM DISCLOSURE AND DISSEMINATION TO ALL THIRD PARTIES.

RELIABILITY NOTE  
OUR MANY YEARS OF EXPERIENCE DATA ACCUMULATION INDICATE THAT SOLDER HEAT IS A MAJOR CAUSE OF EARLY AND FUTURE FAILURE. PLEASE PAY ATTENTION TO YOUR SOLDERING PROCESS.



290 E. HELEN ROAD  
PALATINE, IL 60067-6976  
PHONE: +1.847.359.2790  
US WEB: www.lumex.com  
TW WEB: www.lumex.com.tw

DRAWN BY:	CHECKED BY:	APPROVED BY:	DATE: 6.17.99
BC			PAGE: 1 OF 1
			SCALE: N/A