

IS32LT3181 75mA, 6-CHANNEL CONSTANT CURRENT REGULATOR WITH OTP FOR AUTOMOTIVE REAR TAIL LIGHT

DESCRIPTION

The IS32LT3181 is a six channel linear current regulator for automotive rear tail light applications such as RCL (Rear Combination Lamps) and CHMSL (Center High Mounted Stop Lamps). It is fully programmable with two LED brightness levels for the different intensity requirements of “stop” bright (DC mode) and “tail” dim (PWM mode).

A logic level at the PWM pin is used to select between the tail and stop output conditions. The stop condition provides the highest intensity output, while the tail condition utilizes an internally generated PWM signal to reduce the intensity of the LEDs’ light output.

An active low fault output signal reports a device error condition. The FAULTB pin of several devices can be tied together to disable all the output stages when a fault is detected by any one of the devices.

The sink current at the OUTx pins is easily set with a single resistor at the STOP pin. The constant-current sink outputs can be combined in parallel to create higher current-driving capability on a single string. A second resistor at the TAIL pin sets the duty cycle of the internal PWM oscillator for dimming the LED output when operating in the tail condition.

An external FET (optional) can be implemented for operation with wide varying supply voltages to minimize device thermal dissipation.

The IS32LT3181 is offered in an eTSSOP-16 package.

FEATURES

- Operating voltage from 6V to 42VDC
 - Withstand 50V load dump
- 6 constant-current channel sinks
 - Adjustable from 10mA to 75mA per channel
 - Channel paralleling for higher current
 - Low dropout voltage of 0.8V@35mA
 - Slew rate control on each output for better EMI performance
- Integrated PWM dimming engine provides two LED brightness levels without external logic
 - Tail duty cycle programmable from 1% to 95%
 - PWM logic level input selects between full brightness and PWM dimming levels
- Support for optional FET to minimize device power consumption
- Open drain FAULTB reporting pin
 - Programmable FAULTB delay time
 - Programmable UVLO threshold
 - LED open circuit detection
 - STOP pin over current protection
 - Over temperature protection
- Device disable upon fault detection
 - Parallel connection to other devices
- AEC-Q100 qualification(pending)

QUICK START

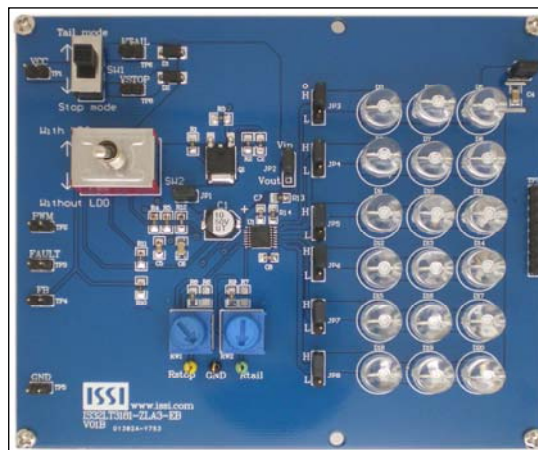

Figure 1: Photo of IS32LT3181 Evaluation Board

RECOMMENDED EQUIPMENT

- 6V~42V, 1A DC power supply
- Multimeter
- 6 strings LEDs (3 LEDs in series of each string, the total forward voltage is around 6V, the rated current is not less than 100mA)

ABSOLUTE MAXIMUM RATINGS

- ≤ 50V power supply

Caution: Do not exceed the conditions listed above; otherwise the board will be damaged.

PROCEDURE

The IS32LT3181 demo board is fully assembled and tested. Follow the steps listed below to verify board operation.

Caution: Do not turn on the power supply until all connections are completed.

- 1) Connect the negative terminal of power supply to GND header (TP5).
- 2) Connect the positive terminal of power supply to connector VCC header (TP1).
- 3) Select JP3~JP8 to configure output LED strings (refer to JUMPER/SWITCH SETTING TABLE)
- 4) Close JP9 to use the onboard LEDs

Note: Open JP9 only if external LEDs are to be used. Connect Pin1 of TP7 to each anode of the external LED strings. Connect Pin 2~Pin 7 to the corresponding cathode of the external LED string.



IS32LT3181 75MA, 6-CHANNEL CONSTANT CURRENT REGULATOR WITH OTP FOR AUTOMOTIVE REAR TAIL LIGHT

- 5) Close JP1.
The device FAULT flag can be monitored by an external circuit on TP3.
Note: The voltage level of this fault signal is pulled up to the supply voltage. Disconnect JP1 if this voltage level exceeds the monitoring circuit's logic high parameter rating. Since the Fault flag output of the IS32LT3181 is open drain, it is possible to supply a lower voltage at R12's JP1 pin which will not damage the monitoring circuit.
- 6) The output current of all channels in "STOP" mode can be adjusted by the potentiometer resistor RW1. Turn RW1 counter clockwise to increase and clockwise to decrease the output current of all channels. The final resistance can be measured with an ohm meter across test point "R_{STOP}" and GND point.
- 7) The PWM duty cycle of "TAIL" mode can be adjusted by the potentiometer resistor RW2. Turn RW2 counter clockwise to decrease and clockwise to increase the duty cycle. The final resistance can be measured with an ohm meter across test point "R_{TAIL}" and GND point.
- 8) If the total forward voltage drop between V_{CC} to LED string (V_{CC} - V_{STRING}) is high, the IS32LT3181 may begin to overheat. It is recommended to use the onboard linear regulator to minimize the voltage across the OUT1~6 pins. Toggle SW2 up to "With LDO" to enable the onboard PMOS FET and transfer some power consumption from the IS32LT3181 to the external PMOS FET.
Toggle SW2 down to "without LDO" to disable the onboard PMOS FET if the (V_{CC} - V_{STRING}) can be kept low so the IS32LT3181 does not over heat.
Note: The (V_{CC} - V_{STRING}) can be minimized by either increasing the total LED string forward voltage drop, ie adding more LEDs in the string or by lowering the V_{CC} supply voltage.
- 9) Toggle SW1 up and down to choose between "STOP" and "TAIL" modes.
- 10) Close JP2 to enable the UVLO function or open to disable this function. Set the under voltage lockout to prevent false triggering during power up.
- 11) Turn on the power supply.

ORDERING INFORMATION

Part No.	Temperature Range	Package
IS32LT3181-ZLA3-EB	-40°C to +125°C (Automotive)	eTSSOP-16, Lead-free

Table 1: Ordering Information

For pricing, delivery, and ordering information, please contacts ISSI's analog marketing team at analog@issi.com or (408) 969-6600.

IS32LT3181 75MA, 6-CHANNEL CONSTANT CURRENT REGULATOR WITH OTP FOR AUTOMOTIVE REAR TAIL LIGHT

JUMPER/SWITCH SETTING TABLE

Jumper/Switch	Options	Setting
JP1	Pulls the FAULT flag pin up to onboard V_{CC} .	Close: Pull up Open: Floating
JP2	Enable/disable the UVLO function.	Close: Enable Open: Disable
JP9	Onboard power to the LED strings (D3 ~ D20)	Close: Power ON Open: Power OFF
JP3-JP8	Correspond to OUT1-OUT6. Enable/disable the corresponding LED strings. Unused channel(s) must connect their corresponding jumper to 'L' (GND), otherwise it will mistakenly trigger the fault flag.	H: Enable L: Disable
TP7	External LED string connector, Pin 1 connects to the common anode of the external LED strings, Pin 2~Pin 7 correspond to OUT1~OUT6, connect to the 1~6 cathode of the external LED strings.	JP9 must be open
SW1	Choose operation mode: 'STOP' or 'TAIL'	Up: TAIL Down: STOP
SW2	Enable/disable onboard linear regulator	Up: Enable Down: Disable

IS32LT3181 75mA, 6-CHANNEL CONSTANT CURRENT REGULATOR WITH OTP FOR AUTOMOTIVE REAR TAIL LIGHT

PROGRAMMING THE OUTPUT CURRENT

A single programming resistor (R_{STOP}) controls the maximum sink current for each LED channel. The STOP pin provides a reference voltage of 1.08V (Typ.). The programming resistor may be computed using the following Equation (1):

$$I_{OUT} = 100 \times \frac{1.08V}{R_{STOP}} \quad (1)$$

The current which is drawn from the STOP pin is internally mirrored to each of the 6 outputs with a multiplication factor of 100A/A. Thus, an output current of 50mA would require a current to be drawn from STOP of 500 μ A, corresponding to an external programming resistance of 2.16k Ω .

PROGRAMMING THE PWM DUTY CYCLE

A single external resistor on the TAIL pin sets the PWM duty cycle which determines the lower intensity TAIL condition. The TAIL pin supplies a constant current of 100 μ A. The PWM duty cycle (D_{cycle}) is set by the following Equation (2):

$$D_{cycle} = \left(\frac{100\mu A \times R_{TAIL}}{4V} - 0.1 \right) \times 100\% \quad (2)$$

Internally, a sawtooth waveform with a peak value of 4.4V and a minimum value of 0.4V is compared to the voltage of the TAIL pin (100 μ A \times R_{TAIL}). The fixed frequency of the sawtooth waveform is 1kHz resulting in a PWM signal of 1kHz at the programmed duty cycle. Thus, for example, a 50% duty cycle would require the reference voltage at TAIL to be 2.4V, corresponding to an external resistance value of 24k Ω .

FAULTB OUTPUT OPERATION

A FAULTB pin assertion can be delayed. This fault delay time consists of T1 and T2. T1 is the built-in deglitch time. If an open LED fault occurs, T1 is about 4 μ s. If R_{STOP} pin over current fault or thermal shutdown occurs, T1 is about 100ns. T2 can be set by connecting a capacitor from the DELAY pin to GND. The device internally sources a 2 μ A (I_{DELAY}) current to charge this capacitor and monitor the voltage of this pin. Once it reaches the threshold voltage of 1.2V (V_{DELAY}), the FAULTB pin will be asserted. So the delay time t_D can be calculated by the following equation (3):

$$t_D = \frac{V_{DELAY} \times C_{DELAY}}{I_{DELAY}} \quad (3)$$

Note: the minimum value of this delay capacitor is 10pF. The DELAY pin CANNOT be left floating.

THE UNDERVOLTAGE LOCKOUT

The LED(s) open fault reporting is enabled by UVLO pin voltage exceeding the UVLO threshold. A resistive voltage divider from VCC to GND is used for preventing false triggering during power up. The fault UVLO voltage could be set by the following Equation (4):

$$V_{UVLO} = V_{UVLO_TH} \times \left(\frac{R_{13}}{R_{14}} + 1 \right) \quad (4)$$

To disable the FAULTB reporting, the UVLO pin voltage has to drop more 50mV lower than V_{UVLO_TH} .

POWER DISSIPATION

The LED power is proportional to the voltage across the LED and the sink current that can be defined as:

$$P_{LED} = \sum_{x=1}^6 V_{LEDSx} \times I_{OUTx}$$

Where x is a number of 1~6. P_{LED} is the power all LED strings. V_{LEDSx} is the total forward voltage of each LEDs string. I_{OUTx} is the current of each LED string.

When working with the LDO in the 'STOP' condition, the power dissipation on the PMOS FET:

Where x is a number of 1~6. V_{OUTx} is the OUTx pin voltage of IS32LT3181. V_{STRING} is the LDO output voltage. I_{CC} is the operation current of IS32LT3181.

$$P_{FET} = \sum_{x=1}^6 (V_{CC} - V_{STRING}) \times I_{OUTx}$$

$$V_{STRING} = V_{FB} \times \left(\frac{R_{11}}{R_{10}} + 1 \right)$$

Note: The recommended R_{10} is 1k Ω . Setting V_{STRING} should remain sufficient V_{OUTx} to insure the current sink operation. Please refer to datasheet to set a proper V_{OUTx} .

The power dissipation on IS32LT3181:

$$P_{3181} = V_{CC} \times I_{CC} + \sum_{x=1}^6 V_{OUTx} \times I_{OUTx}$$

$$V_{OUTx} = V_{STRING} - V_{LEDSx}$$

IS32LT3181 75MA, 6-CHANNEL CONSTANT CURRENT REGULATOR WITH OTP FOR AUTOMOTIVE REAR TAIL LIGHT

Assume all channels are on, $I_{OUTX}=35\text{mA}$, $V_{LEDSX}=9.6\text{V}$,
 $V_{CC}=14\text{V}$, $I_{CC}=6\text{mA}$, $R_{11}=9.1\text{k}\Omega$, $R_{10}=1\text{k}\Omega$.

$$P_{LED}=9.6\text{V}\times 0.035\text{A}\times 6=2.016\text{W}$$

$$V_{STRING}=1.05\text{V}\times (9.1\text{k}\Omega/1\text{k}\Omega+1)=10.605\text{V}$$

$$P_{FET}=(14\text{V}-10.605\text{V})\times 0.035\text{A}\times 6=0.71295\text{W}$$

$$P_{3181}=(10.605\text{V}-9.6\text{V})\times 0.035\text{A}\times 6+14\text{V}\times 0.006\text{A} \\ =0.29505\text{W}$$

When input voltage V_{CC} varies, the LDO will keep V_{STRING} constant and the power dissipation on IS32LT3181 also will be constant.

Caution: V_{CC} must be higher than V_{STRING} to insure stable system operation. The PMOS FET and IS32LT3181 must be mounted over a large area copper plate on the PCB to enhance heat-sink performance.

IS32LT3181 75mA, 6-CHANNEL CONSTANT CURRENT REGULATOR WITH OTP FOR AUTOMOTIVE REAR TAIL LIGHT

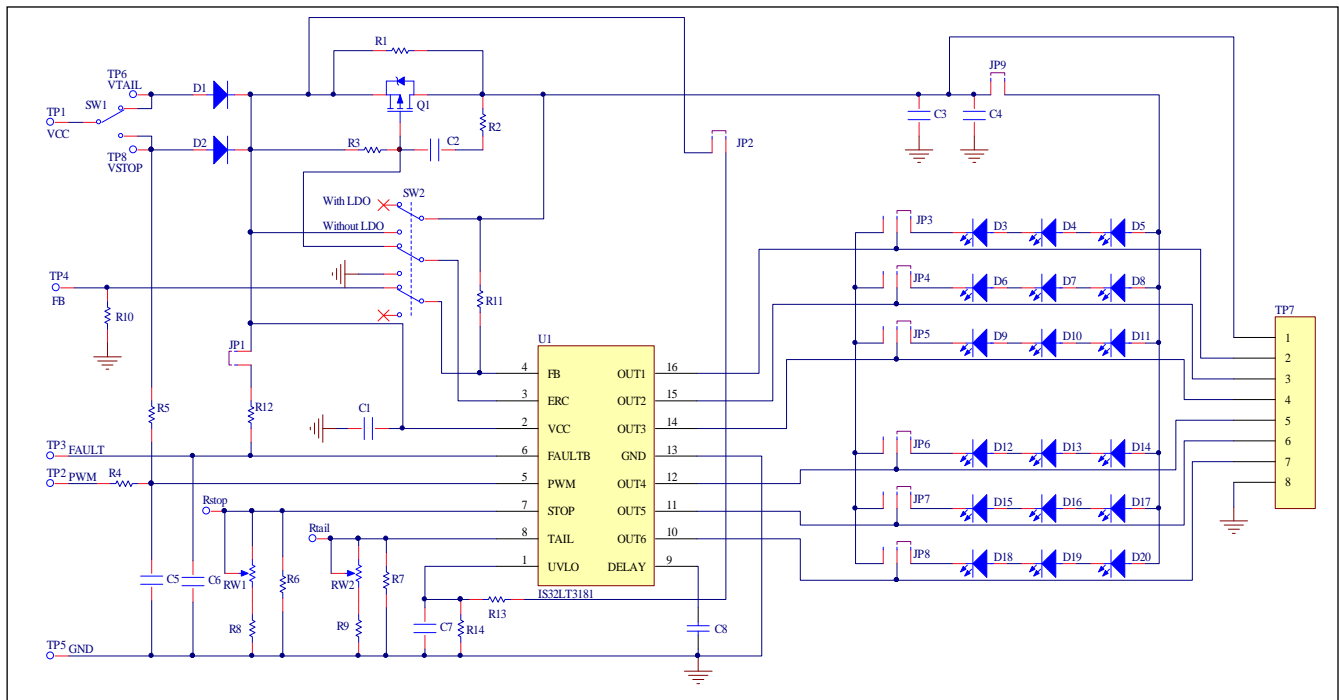

Figure 2: IS32LT3181 Application Schematic



IS32LT3181 75MA, 6-CHANNEL CONSTANT CURRENT REGULATOR WITH OTP FOR AUTOMOTIVE REAR TAIL LIGHT

BILL OF MATERIALS

Name	Symbol	Description	Qty	Supplier	Part No.
LED Driver	U1	Constant current LED driver	1	ISSI	IS32LT3181
E-Cap	C1	CAP,10 μ F,50V, \pm 20%	1	Panasonic	EEE-1HA100WR
Capacitor	C2	CAP,0.22 μ F,50V, \pm 10%,SMD	1	Yageo	CC0603KKX7R9BB224
Capacitor	C3,C4	CAP,0.1 μ F,50V, \pm 10%,SMD	2	Yageo	CC0805KKX7R9BB104
Capacitor	C5	CAP,10nF,50V, \pm 10%,SMD	1	Yageo	CC0805KKX7R9BB103
Capacitor	C6,C7,C8	CAP,1nF,50V, \pm 10%,SMD	3	Yageo	CC0805KKX7R9BB102
Resistor	R1,R3,R14	RES,1k,1/4W, \pm 1%,SMD	3	Yageo	RC0805FR-0701KL
Resistor	R8,R9	RES,820R,1/4W, \pm 1%,SMD	2	Yageo	RC0805FR-07820RL
Resistor	R6,R7	Not connect	2		
Resistor	R2	RES,51R,1/4W, \pm 5%,SMD	1	Yageo	RC0805JR-0750R1L
Resistor	R4,R5	RES,10K,1/4W, \pm 5%,SMD	2	Yageo	RC0805JR-0710KL
Resistor	R10	RES,910R,1/4W, \pm 5%,SMD	1	Yageo	RC0805JR-07910RL
Resistor	R11	RES,5.6K,1/4W, \pm 1%,SMD	1	Yageo	RC0805FR-075K6L
Resistor	R12	RES,100K,1/4W, \pm 1%,SMD	1	Yageo	RC0805FR-07100KL
Resistor	R13	RES,6.2K,1/4W, \pm 1%,SMD	1	Yageo	RC0805FR-076K2L
PFET	Q1	60V/12A,P-Channel MOS	1	ONsemi	NTD2955-1G
Potentiometer	RW1	Trimmer 20kohm \pm 10% 0.5W	1	Bourns	3386P-1-203
Potentiometer	RW2	Trimmer 50kohm \pm 10% 0.5W	1	Bourns	3386P-1-503
Diode	D1,D2	1A,600V,DO-214AC,SMA	2	Fairchild	ES1J
LED	D3~D20	F8mm, $V_F=2.1V$ @ $I_F=150mA$,Red LED	18		
Switch	SW1	SPDT,13mm \times 6.5mm,1A	1		
Switch	SW2	3PDT,16.5mm \times 12.7mm,1A	1		
Header	TP7	8 pin headers	1		
Header	JP3~JP8	3 pin headers	7		
Header	TP1~TP6, TP8,JP1~2,JP9	2 pin headers	9		

Bill of Materials refers to Figure 2 above.

IS32LT3181 75mA, 6-CHANNEL CONSTANT CURRENT REGULATOR WITH OTP FOR AUTOMOTIVE REAR TAIL LIGHT

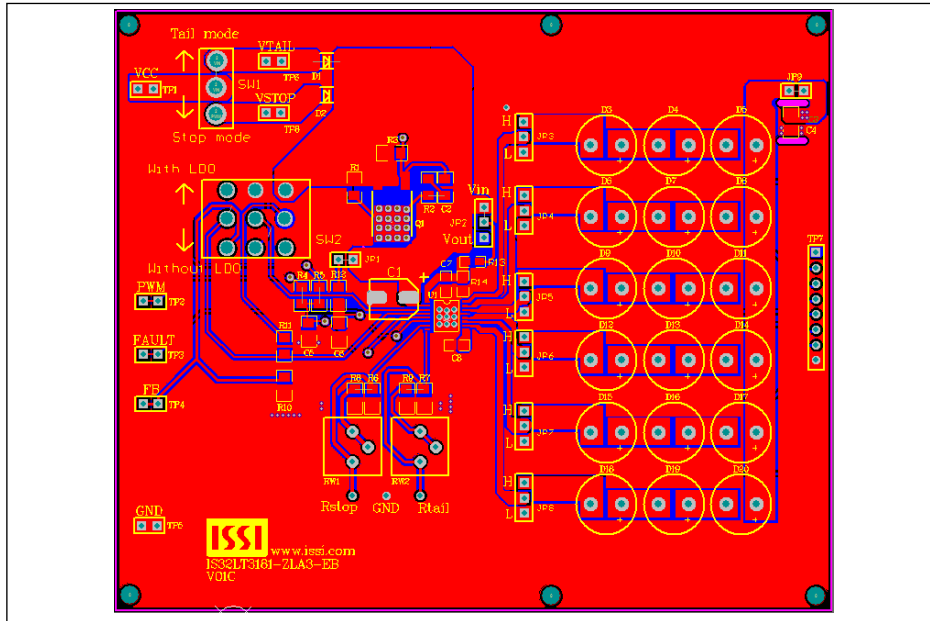

Figure 3: Board PCB Layout - Top Layer

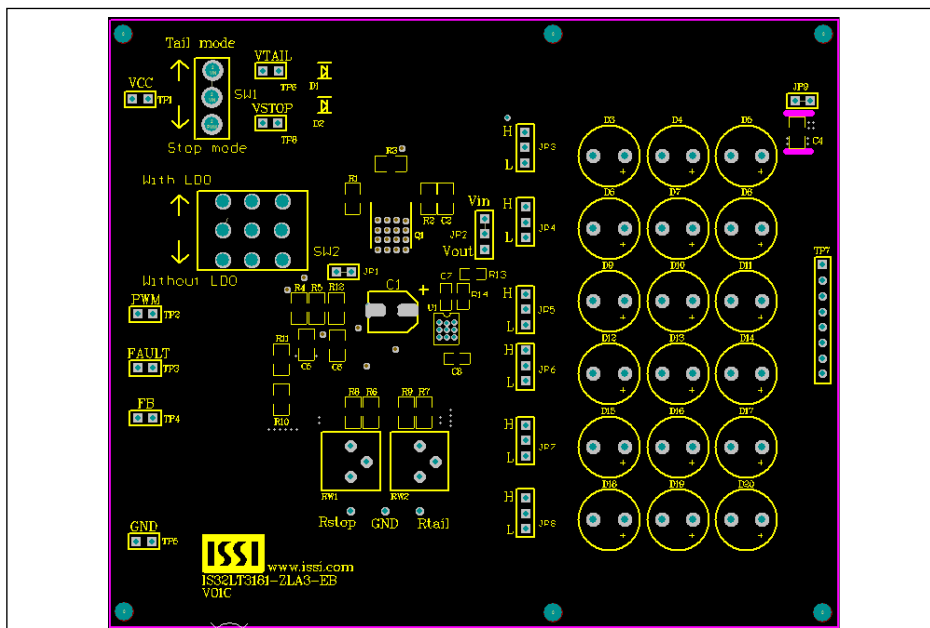

Figure 4: Board Component Placement Guide - Top Layer

**IS32LT3181 75MA, 6-CHANNEL CONSTANT CURRENT
REGULATOR WITH OTP FOR AUTOMOTIVE REAR TAIL LIGHT**

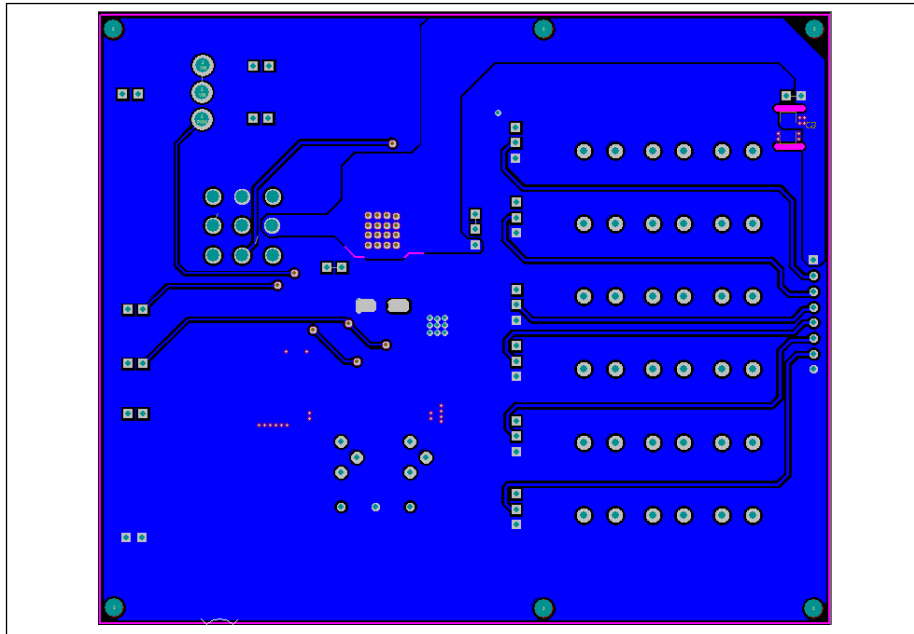

Figure 5: Board PCB Layout - Bottom Layer

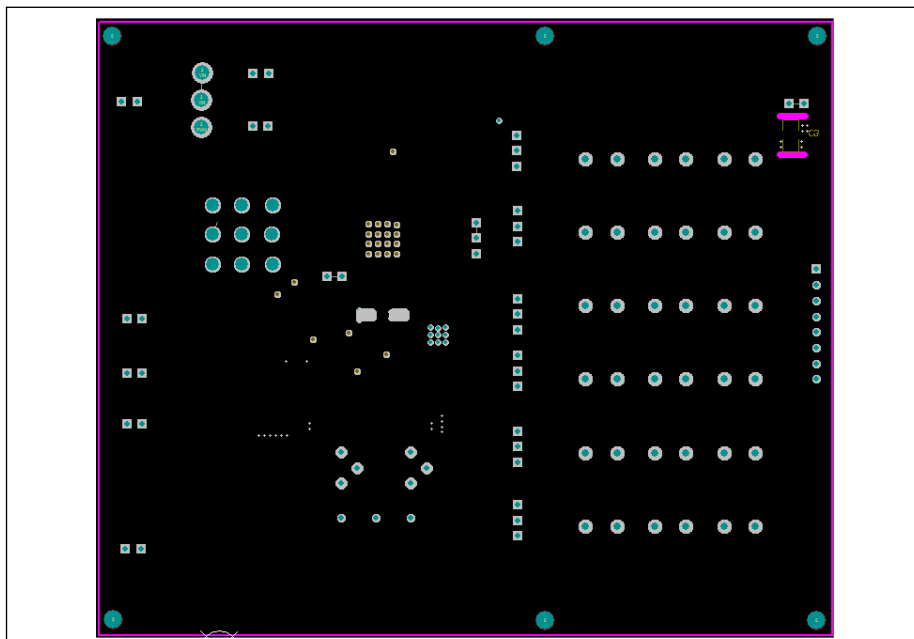

Figure 6: Board Component Placement Guide - Bottom Layer

Copyright © 2016 Integrated Silicon Solution, Inc. All rights reserved. ISSI reserves the right to make changes to this specification and its products at any time without notice. ISSI assumes no liability arising out of the application or use of any information, products or services described herein. Customers are advised to obtain the latest version of this device specification before relying on any published information and before placing orders for products.

Integrated Silicon Solution, Inc. does not recommend the use of any of its products in life support applications where the failure or malfunction of the product can reasonably be expected to cause failure of the life support system or to significantly affect its safety or effectiveness.

Products are not authorized for use in such applications unless Integrated Silicon Solution, Inc. receives written assurance to its satisfaction, that:

- a.) the risk of injury or damage has been minimized;
- b.) the user assume all such risks; and
- c.) potential liability of Integrated Silicon Solution, Inc is adequately protected under the circumstances