

THIS DOCUMENT IS THE PROPERTY OF KEYSTONE ELECTRONICS CORP. AND SHALL NOT BE REPRODUCED, DISTRIBUTED OR USED AS A BASIS FOR MANUFACTURE WITHOUT PRIOR WRITTEN PERMISSION FROM KEYSTONE ELECTRONICS CORP.

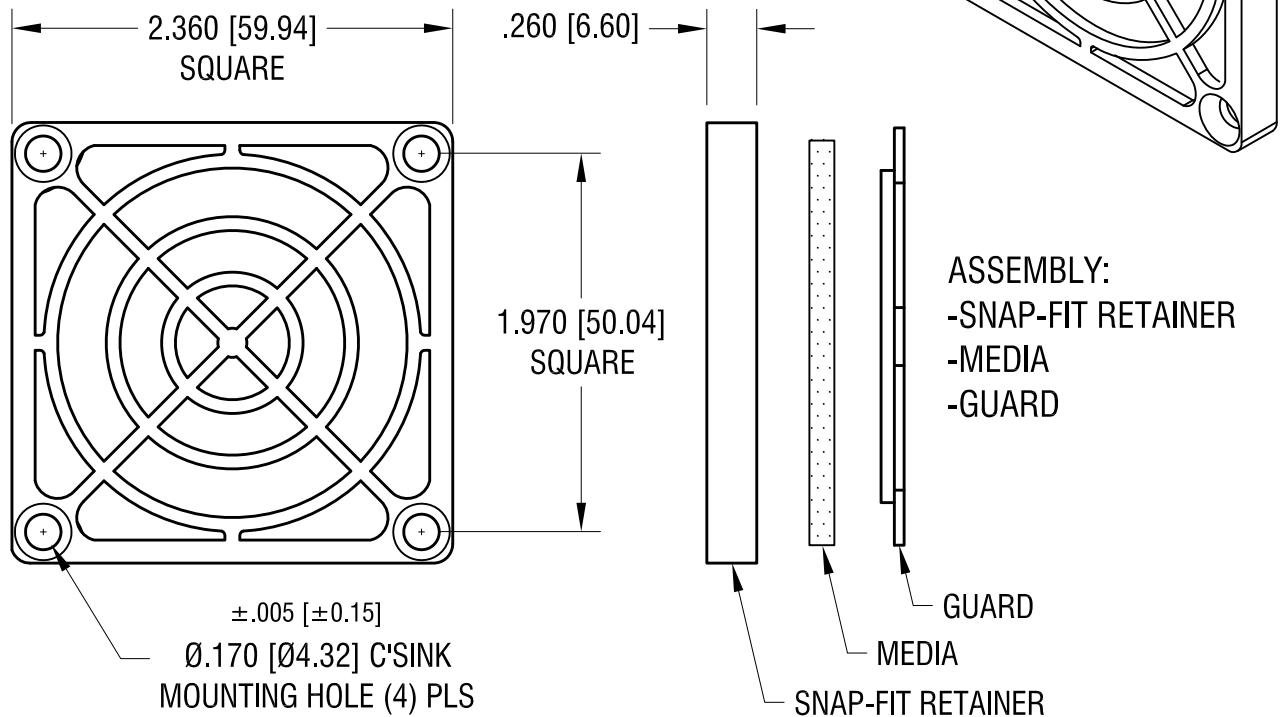

NOTES:

- 1. RETAINER: MAT'L - ABS UL 94V-0
- MEDIA: MAT'L - POLYURETHANE FOAM
- GUARD: MAT'L - ABS UL 94V-0

3.25.10	CHANGE AS PER ECN 10-024	A
DATE	DESCRIPTION	REV.

KEYSTONE ELECTRONICS CORP.			
www.keyelco.com • ASTORIA, N.Y. 11105-2017 • Tel (718) 956-8900			
PART NAME		MINI-FAN GUARD ASSEMBLY	
MATERIAL		AS NOTED	
FINISH	-	DRN BY	BOONE
		APP'D	LN
		DATE	12.11.06
		SCALE	1X
TOLERANCES	INCH [MM]	CODE	DWG NO.
DECIMAL	± .020 [± 0.50]	C/M	8465
ANGULAR	± 1°		
UNLESS OTHERWISE SPECIFIED			