

DATE	REV	ECN	APP'D. BY
12-15-15	C3	10480	TRM
3-30-16	C4	10653	TRM

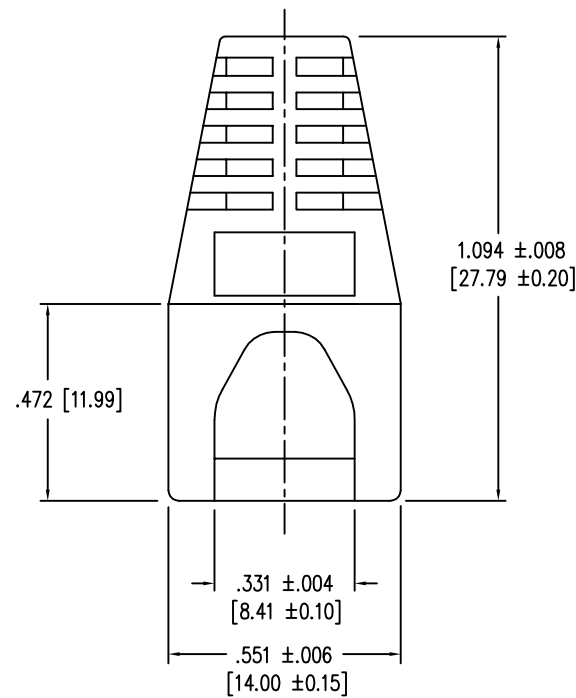

PART NUMBER	COLOR
450-011	BLACK
450-012	DARK GREY
450-013	YELLOW
450-014	GREEN
450-015	BLUE
450-016	LIGHT GREY
450-017	PURPLE
450-018	WHITE

NOTES:
 1. CONNECTOR MATERIALS:
 HOUSING: THERMOPLASTIC UL94 V-0

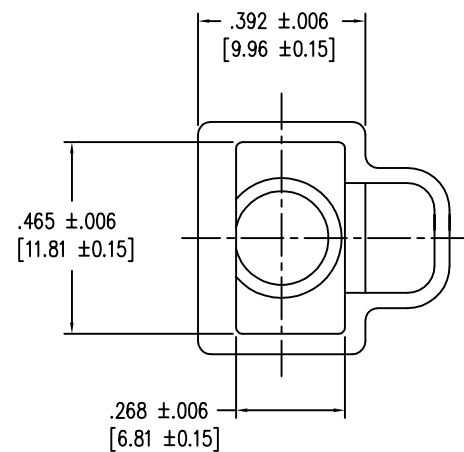
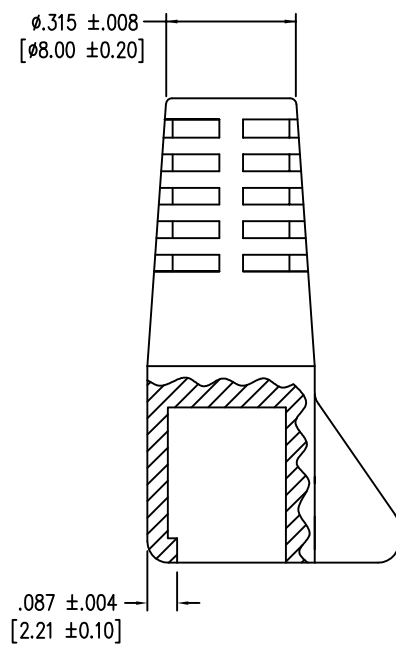
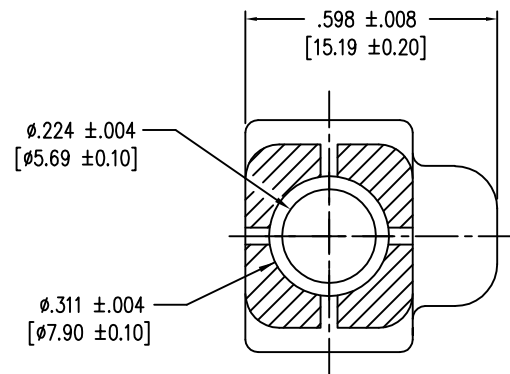
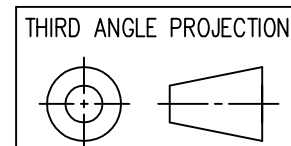

1118 Susquehanna Trail South
 Glen Rock, PA 17327-9199
 (717) 235-7512
<http://www.stewartconnector.com>

DO NOT SCALE DRAWING
 DRAWING IS SUBJECT TO
 CHANGE WITHOUT NOTICE

TITLE: EXTERNAL STRAIN RELIEF BOOT

DIMENSIONS: INCHES [METRIC]
 UNLESS OTHERWISE SPECIFIED
 TOLERANCES ARE ±.005 [0.13]
 ANGLES ARE ± 1°

THIS DRAWING AND THE SUBJECT MATTER SHOWN THEREON
 ARE CONFIDENTIAL AND THE PROPRIETARY PROPERTY OF
 STEWART CONNECTOR AND SHALL NOT BE REPRODUCED,
 COPIED, OR USED IN ANY MANNER WITHOUT PRIOR WRITTEN
 CONSENT OF STEWART CONNECTOR. ONE OR MORE U.S. PATENTS
 MAY APPLY TO THIS PRODUCT. FOR DETAILS, PLEASE
 VISIT: [HTTP://BELFUSE.COM/STEWART/STEWART_PATENTS/](http://BELFUSE.COM/STEWART/STEWART_PATENTS/)

DRN BY:	DAB	DATE	9/9/03
APPD BY:	RGC	DATE	9/12/03
DWG NO.	CT999002	REV.	C4

SHEET NO. 1 OF 1

