

THIS DRAWING IS UNPUBLISHED. RELEASED FOR PUBLICATION 20
 © COPYRIGHT 20 BY - ALL RIGHTS RESERVED.

REVISIONS

P	LTR	DESCRIPTION	DATE	DWN	APVD
A1	ECR-15-004309		19MAR2015	DW	CW
A2	ECR-15-007632		25MAY2015	DW	CW
B	ECR-15-013292		24SEP2015	DL	CW
B1	ECR-16-015492		21NOV2016	QY	CW

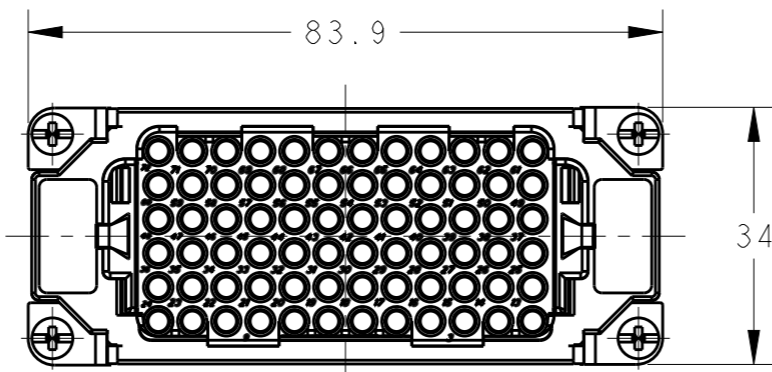
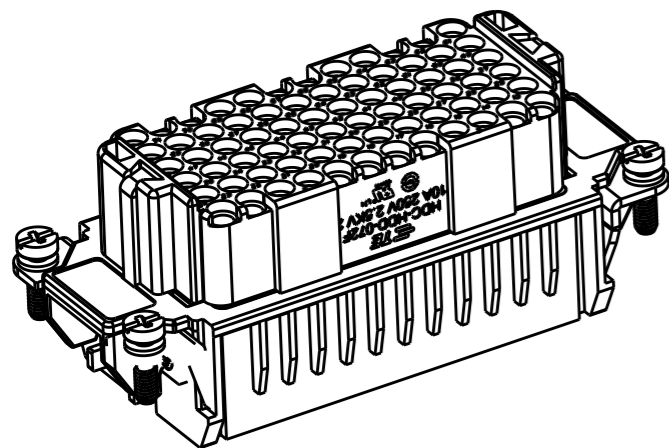

4X M3 SCREW RECOMMENDED
 TIGHTENING TORQUE 0.5Nm
 4X M3螺丝, 推荐锁紧力矩0.5Nm

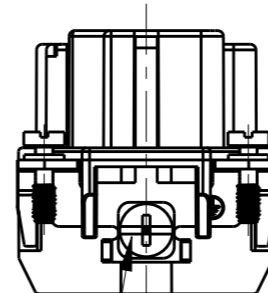
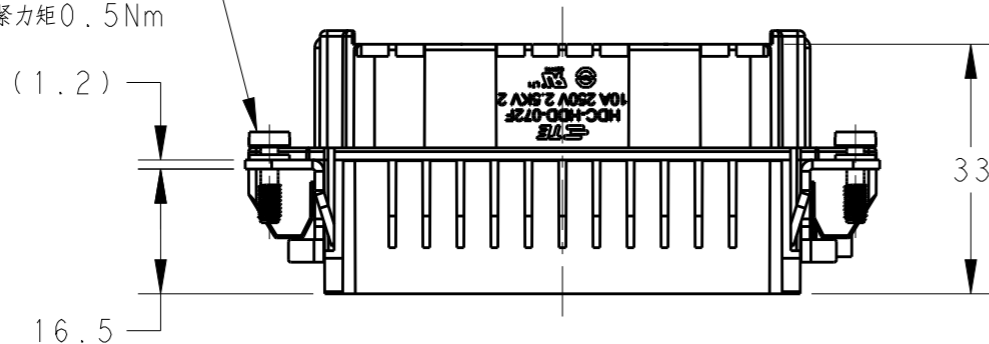

M4 SCREW RECOMMENDED
 TIGHTENING TORQUE 1.2Nm
 M4 螺丝, 推荐锁紧力矩1.2Nm

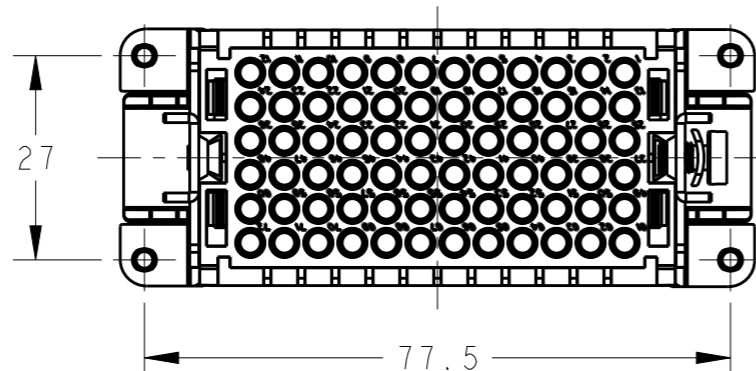

NOTES:

- TECHNICAL CHARACTERISTICS:
 INSULATION MATERIAL: PC
 RATED VOLTAGE: 250 V
 RATED CURRENT: 10 A
 INSULATION RESISTANCE: $\geq 400M\Omega$
 RATED IMPULSE VOLTAGE: 2.5 KV
 POLLUTION DEGREE: 2
 FLAMMABILITY: UL94V-0
 MATING CYCLES: 500 CYCLES
 WIRE RANGE: 0.14-2.5 mm² (26-14 AWG)
 CONTACT TYPE: CRIMP CONTACT
- CONTACT NEED TO BE ORDERED SEPARATELY.
 (ORDER No. REFER TO DRAWING: T20200X20XX000)

注释:

- 技术参数:
 绝缘材料: PC
 额定电压: 250V
 额定电流: 10A
 绝缘电阻: $\geq 400M\Omega$
 额定脉冲电压: 2.5 KV
 污染等级: 2
 阻燃等级: UL94V-0
 插拔次数: 500次
 接线范围: 0.14-2.5 mm² (26-14 AWG)
 接线类型: 冷压接
- 端子需要单独订购.
 (订货号参考图面: T20200X20XX000)

TYPE-1, T2030722201-000, TE LOGO
 类型-1, T2030722201-000, TE LOGO

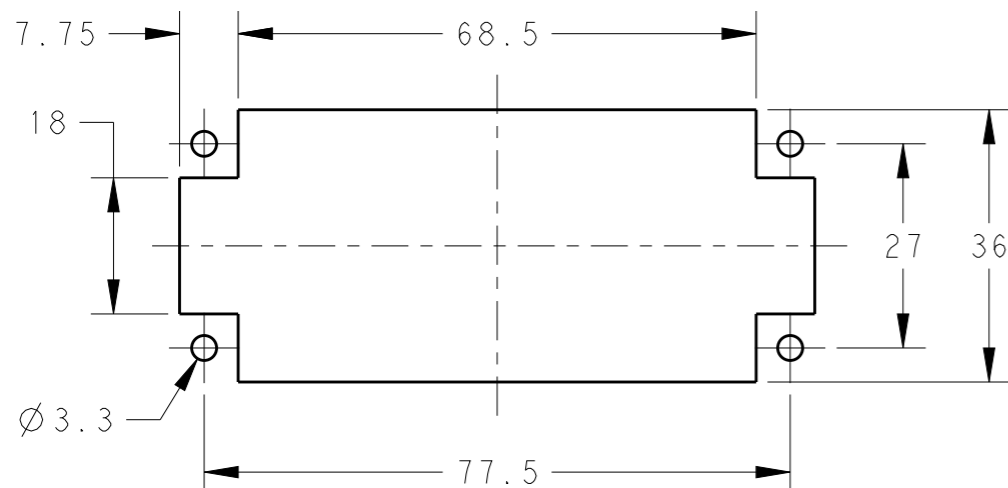

PANEL CUT OUT FOR INSERTS FOR USING
 WITHOUT HODDS/HOUSINGS
 不用防护外壳时芯件的安装开孔图

THIS DRAWING IS A CONTROLLED DOCUMENT.		DWN 29OCT2014 David Wang		 TE Connectivity	
DIMENSIONS: mm		CHK 29OCT2014 Chris Wang			
TOLERANCES UNLESS OTHERWISE SPECIFIED:		APVD 29OCT2014 Xiang Xu		NAME HDD-072-F	
0 PLC ±-		PRODUCT SPEC 108-137043		SIZE A3	
1 PLC ±-		APPLICATION SPEC 114-137043		CAGE CODE 00779	
2 PLC ±-		WEIGHT -		DRAWING NO T2030722201000	
3 PLC ±-		Customer Drawing		RESTRICTED TO -	
4 PLC ±-		SCALE 1:1		SHEET 1 OF 2	
ANGLES ±-		FINISH -		REV B1	
MATERIAL -		FINISH -			

4

3

2

1

THIS DRAWING IS UNPUBLISHED.

RELEASED FOR PUBLICATION

20

© COPYRIGHT 20 BY -

ALL RIGHTS RESERVED.

REVISIONS

P	LTR	DESCRIPTION	DATE	DWN	APVD
-		SEE SHEET 1	-	-	-

NOTE:
SEE SHEET 1
注释:
见页 1

TYPE-2, T2030722201-001, STAINLESS STEEL SCREW, NO LOGO
类型-2, T2030722201-001, 不锈钢螺丝, 无LOGO

T2030722201-001	HDD-072-F	HDD-072 FEMALE INSERT, CRIMPING SPLIT TYPE, STAINLESS STEEL SCREW, NO LOGO HDD-072 母插, 冷压针分体式, 不锈钢螺丝, 无LOGO	TYPE-2 类型-2
T2030722201-000	HDD-072-F	HDD-072 FEMALE INSERT, CRIMPING SPLIT TYPE HDD-072 母插, 冷压针分体式	TYPE-1 类型-1
PART NUMBER 料号	PART DESCRIPTION 描述		TYPE 类型

ALL DIMENSIONS ARE SAME AS TYPE 1,
EXCEPT THOSE DEFINED IN THIS TYPE.
除了在本类型中定义的尺寸外, 其它尺寸同类型 1

THIS DRAWING IS A CONTROLLED DOCUMENT.		DWN David Wang 29OCT2014		
DIMENSIONS: mm		CHK Chris Wang 29OCT2014		
TOLERANCES UNLESS OTHERWISE SPECIFIED:		APVD Xiang Xu 29OCT2014	NAME HDD-072-F	
0 PLC ±-		PRODUCT SPEC 108-137043	SIZE	
1 PLC ±-		APPLICATION SPEC 114-137043	CAGE CODE	
2 PLC ±-		WEIGHT -	DRAWING NO A300779	
3 PLC ±-			RESTRICTED TO -	
4 PLC ±-			SCALE 1:1	
ANGLES ±-			SHEET 2 OF 2	
FINISH -			REV B1	
MATERIAL -		Customer Drawing		

1470-19 (3/13)