

SCHEMATIC
▲ ON - ON
DPDT Illuminated

NOTE:

1. ALL DIMENSIONS IN MM [INCH]
2. GENERAL TOLERANCE: X.X = ± 0.4
X.XX = ± 0.25
3. TERMINAL NUMBERS FOR REF ONLY
- ▲ 4. CONTACT MATERIAL: SILVER
5. RATING: 3A 250 VAC cUL
6. ELECTRIC LIFE: 50,000 MAKE-AND-BREAK CYCLES AT FULL LOAD.
7. MECHANICAL LIFE: 500,000 CYCLES.
8. INSULATION RESISTANCE: 1,000 M Ω @ 500VDC MIN.
9. DIELECTRIC STRENGTH: 2,000 VAC MIN. FOR 1 MINUTE
10. CONTACT RESISTANCE: 50m Ω MAX. @ 1A 12VDC
11. OPERATING TEMP.: -20°C to 55°C
12. ▲ DENOTES CRITICAL PARAMETER.
- ▲ 13. LAMP VOLTAGE: 20mA 3V
14. TRAVEL: 3.2mm
15. ACTUATION FORCE: 3.5 \pm 1.0 N
16. MOUNTING NUT TORQUE: 5-14 Nm
17. INGRESS PROTECTION: IP67
18. HARDWARE SUPPLIED: O-RING AND HEXNUT

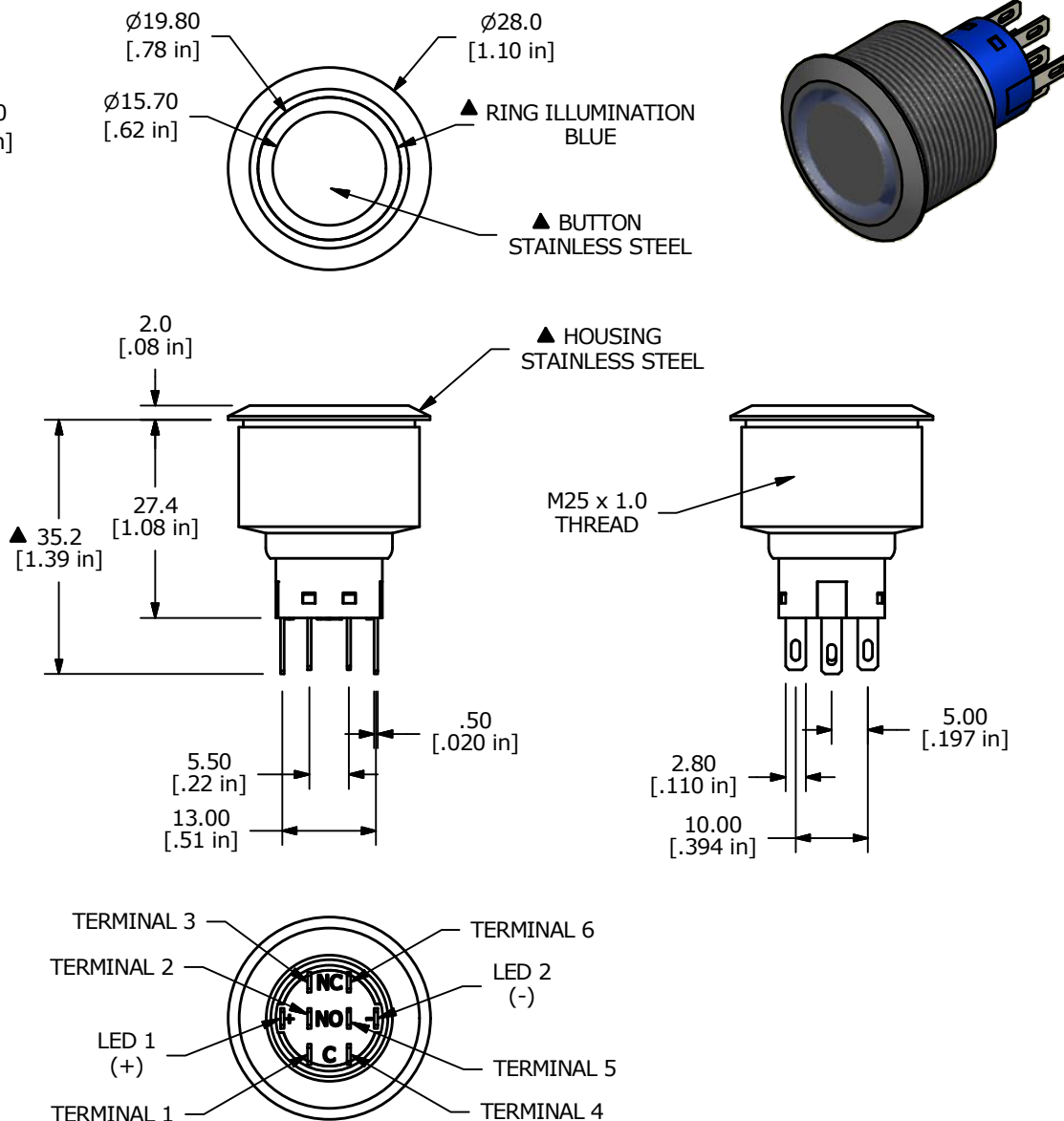

B	22132	drawing updates	1/25/16	MW
A	22094	New Release	1/12/16	rc
REV	PCR NO	DESCRIPTION	DATE	BY

TITLE ULV8F2GSS341				
SCALE 1:1	DATE 9/24/2015	DR rc	DWG T980003	REV B

THE INFORMATION CONTAINED IN THIS DOCUMENT IS PROPRIETARY TO E-SWITCH AND IS NOT TO BE COPIED OR TRANSFERRED